

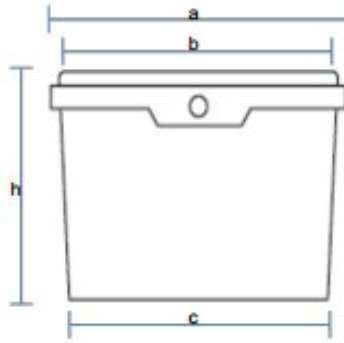

## DIMENSIONS / WEIGHT

Upper diameter (inside):	213,7 mm (b)
Upper diameter (with flange):	225,3 mm (a)
Upper diameter (with handles):	224,0 mm
Bottom diameter (external):	194,5 mm (c)
Height (with standard lid):	187,6 mm (h)
Height (with lid for foiling):	193,7 mm
Nominal capacity:	5 000 ml
Total capacity:	5 900 ml
Total usable capacity:	5 500 ml
Container weight:	143,8 g
Handle weight (strap):	5,6 g (standard)
Handle weight (PP):	8 g (optional)
Handle weight (metal):	20,3 g (optional)
Weight tolerance:	+/- 5%
Dimension tolerance:	+/- 1mm



## PHOTO OF PRODUCT



## DECORATION

	Dry offset (up to 6 colors)	IML
Width (B):	650 mm	643,0 mm
Height (H):	135 mm	169,5 mm

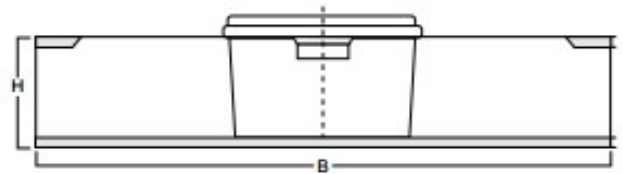

Detailed die cutter of IML label is available after contact with the Sales Department

## LIDS

Name: P-05FB/1  
Foiling: YES  
Weight: 40 g  
IML: YES  
Offset: NO



Name: P-05LB/1  
Foiling: NO  
Weight: 35 g  
IML: YES  
Offset: NO



Name: P-05LB/2  
Foiling: NO  
Weight: 32 g  
IML: YES  
Offset: NO



## RAW MATERIAL / TRANSPORT AND WAREHOUSING

- Buckets and lids are made of polypropylene (pp)
- Warehousing: In the case of stacking pallets with filled containers put weight uniformly, using for example proper separators.
- Filling and closing conditions: max. content temperature during filling 95°C, during stacking content temperature should be lower than 45°C. Put not more than 2 warm containers in the stack. When temperature decrease to 25-30° containers are characterized by optimal rigidity and mechanical parameters allowing stacking for maximal static load as below.
- Load on the lower container:
 

Static (T<23°C) :	< 35 kg	Transparent containers < 28 kg
-------------------	---------	--------------------------------
- Transportation of filled containers: Containers may be stacked to the 66% of maximal static load.
- Palletizing of containers: Product with density 1,0 g/cm3 according to the customer practice giving consideration to the mentioned earlier values.
- All materials and dyes used to produce container or lid designed for the food sector are approved for food contact.
- This guarantee is valid 12 months from date of delivery. During this time, the package should be used. All packages from a single pallet should be used immediately after unpacking.
- Manufacturer is not responsible for container deformation because of stacking of single pallets or putting on them an extra load.

## PALLETIZATION FILLED CONTAINERS

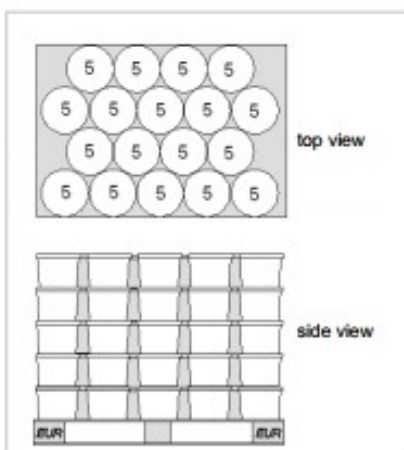

## PALLETIZATION AT DELIVERY

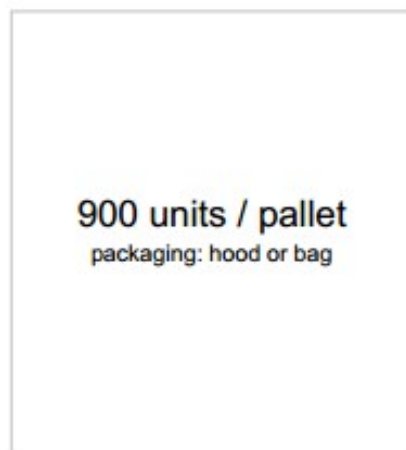

## STANDARD COLOURS



The product is available in white, transparent or colored according to customer specifications