

**LUMI'IN:**

**Solutions solaires et IRVE**

Septembre 2022

# LUMI'IN

## Solutions solaires autonomes

- Créée en 2014
- François VAUTE (CEO) y Laurent SAUREL (Directeur commercial)
- 15 ans d'expérience dans l'Industrie Solaire
- 5 ans de R&D
- 10 000 systèmes solaires installés à travers le monde
- Présence internationale : France, Europe, Afrique, Amérique, Caraïbe, Polynésie, Océan Indien, etc



# Les solutions LUMI'IN

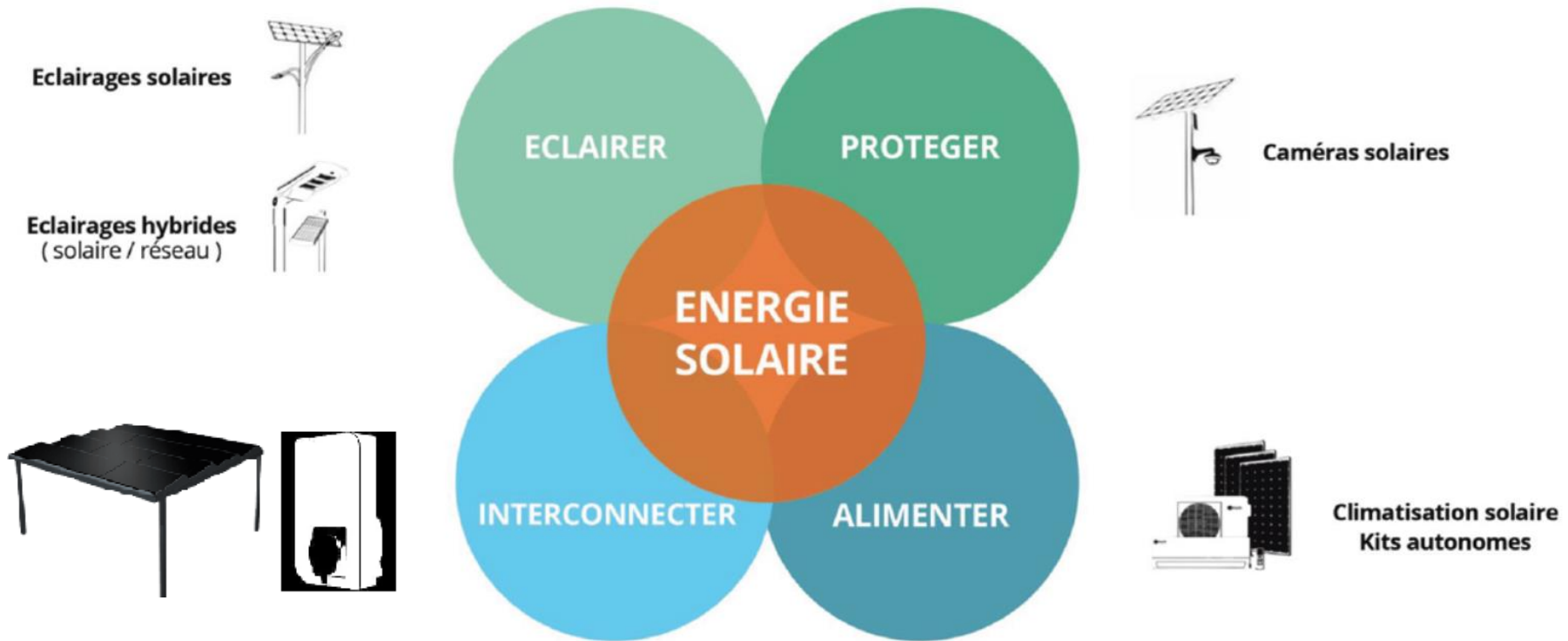

**CAPTER - STOCKER - RESTITUER**

# Produits sur mesure

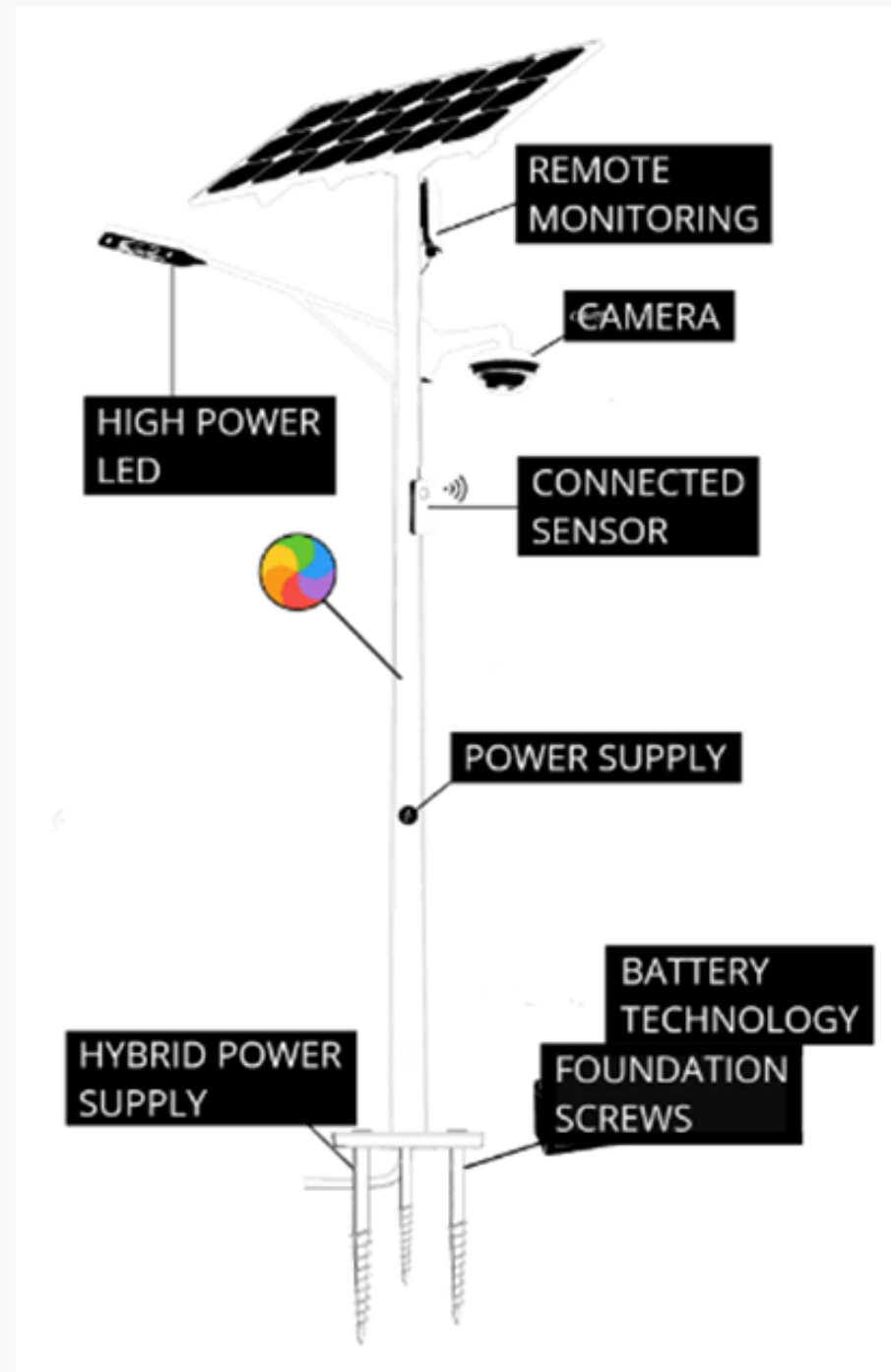



# Carports solaires & solutions IRVE



# CARPORT SOLAIRE LUMI'IN: Gamme PREMIUM



# Carport solaire / IRVE

**Carport solaire sur mesure avec différentes options disponibles:**

- **Hybride:**

Injection sur le réseau ou autoconsommation ou stockage d'énergie avec batteries régénérées

- Chargeurs IRVE jusqu'à 22 kW

- **Eclairages**

- **Caméra** de vidéoprotection

- 2 Gammes

- **Gamme Standard LUMI'IN PRO-R**

Avec fondation béton

Résistance vent: zone 4, jusqu'à 180km/h

- **Gamme Premium LUMI'IN PRO-P**

Structure brevetée => autoportée sans fondation

Résistance vent: zone 5, jusqu'à 230km/h

**Puissance solaire de 3300 a 13 500 Wc**



**De 1 a 4 places.**

**Version sur mesure possible**



# Nouveau produit 2022: Gamme Premium CARPORT PRO-P by LUMI'IN

Panneaux solaires Premium:  
Sunpower, Axitec, Stile, etc  
Mono, Poly, Bifacial



Solaire hybride  
Autonomie avec batteries  
régénérées jusqu'à 50 kWh  
Chargeurs IRVE jusqu'à  
22kW



Télégestion Solaire & IRVE



Struture brevetée  
Autoportée sans fondation  
Lestage intégré au toit  
Résistance vent: zone 5, 230km/h

Thermolaquage Premium :  
Différents RAL possibles dont BDM









**FLEXIRVE LUMI'IN:**  
**3 solutions en 1**  
**Eclairer, Protéger, Charger**



# FLEXIRVE :

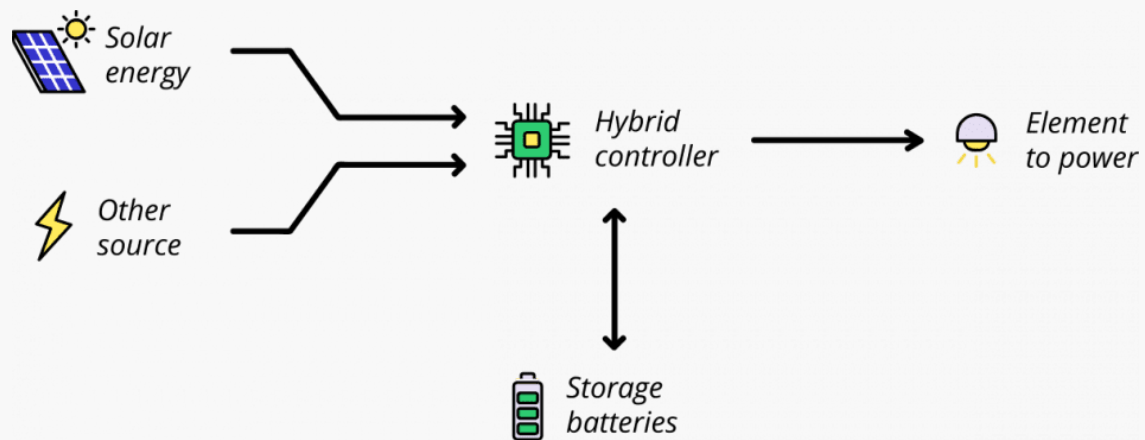

**Luminaire solaire hybride FLEX**  
Solaire & Réseau

**Vidéo protection PTZ 360° 5MP**  
Vision nocturne  
Audio bidirectionnel

**Antenne 4G- Wifi**



**Chargeur IRVE jusqu'à 22kW**  
Intégré au mât  
Type 2  
Télégestion

OPEN E-MOBILITY  
Version 2.4.92

**lumi'n**  
FRANCE

SAMSON  
Thibault

Profil

Se Déconnecter

Bornes

Sessions

Factures

Voitures

Badges

Organisation

BORNES

Réinitialiser les Filtres

Rafraîchissement Auto

Propriétaire

Organisation Actuelle

Entreprises

Sites

Zones

Rechercher

Action(s)	Nom	Site	Zone	Etat	Connecteurs	Puissance instar
>	GARAGEROUMANILLE1	PARKING ROUMANILLE SAINT REMY	PARKING ROUMANILLE SAINT REMY	Connectée	A	0 / 22,1 kW
>	GARAGEROUMANILLE2	PARKING ROUMANILLE SAINT REMY	PARKING ROUMANILLE SAINT REMY	Connectée	A	0 / 22,1 kW
>	GARAGEROUMANILLE3	PARKING ROUMANILLE SAINT REMY	PARKING ROUMANILLE SAINT REMY	Connectée	A	0 / 22,1 kW

Enregistrements: 3



# La solution FLEXIRVE pour développer facilement la mobilité électrique à partir du réseau d'éclairage public

- ▶ Limiter les travaux, économie d'énergie
- ▶ Pas de tranchée, pas de génie civil
- ▶ 3 solutions en 1 : éclairage + borne VE + vidéoprotection
- ▶ Améliorer et mettre à jour le mobilier déjà présent à moindre coût
- ▶ Déployer rapidement une infrastructure borne IRVE

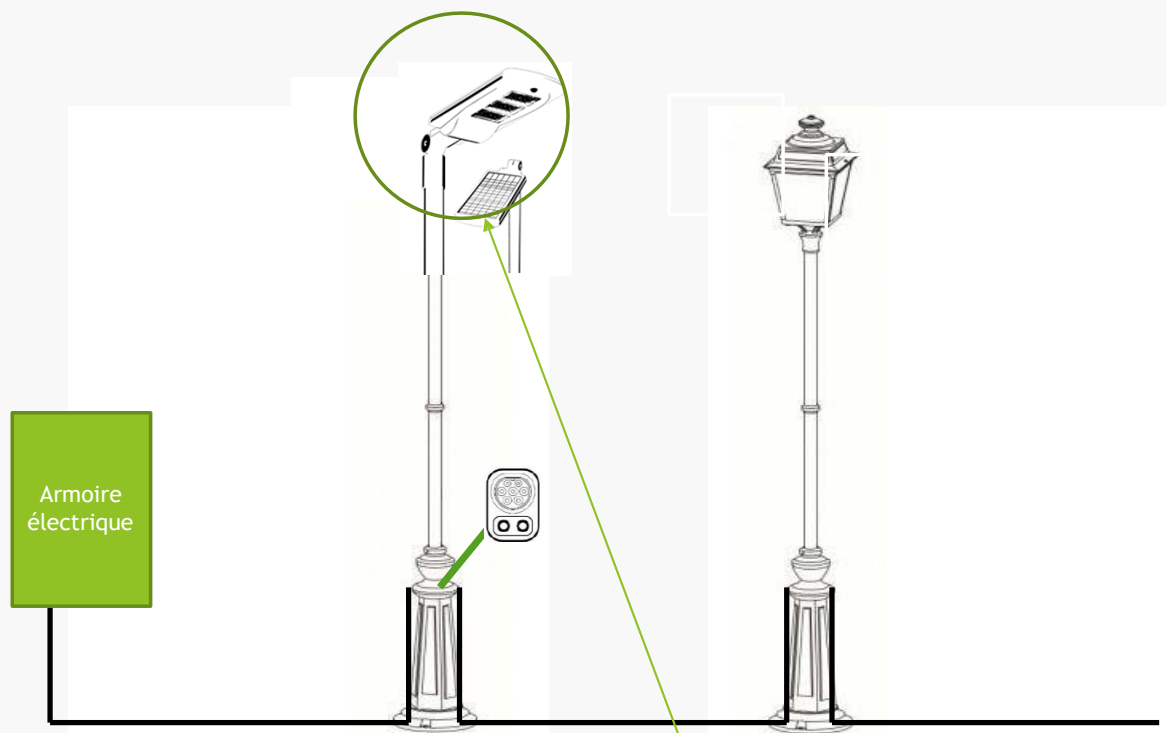

FLEX : Le premier luminaire LED hybride (solaire/réseau), connecté et adaptable sur n'importe quel lampadaire. Son panneau solaire intégré permet de remplacer l'horloge pour piloter l'éclairage

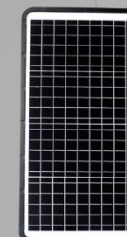

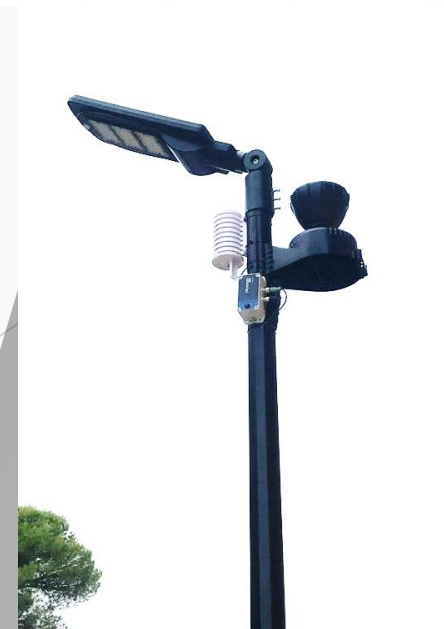
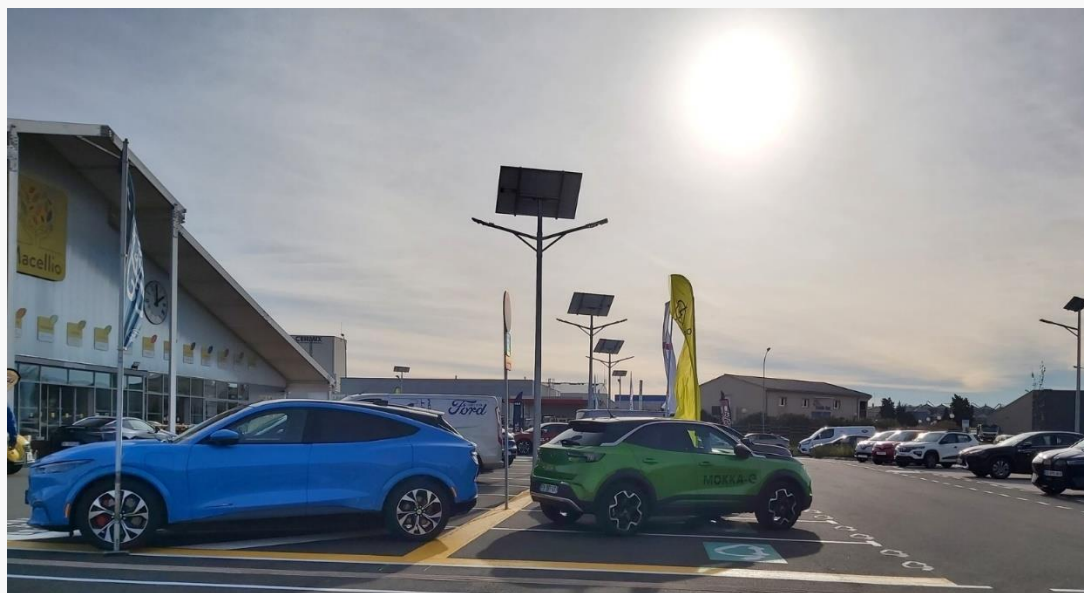
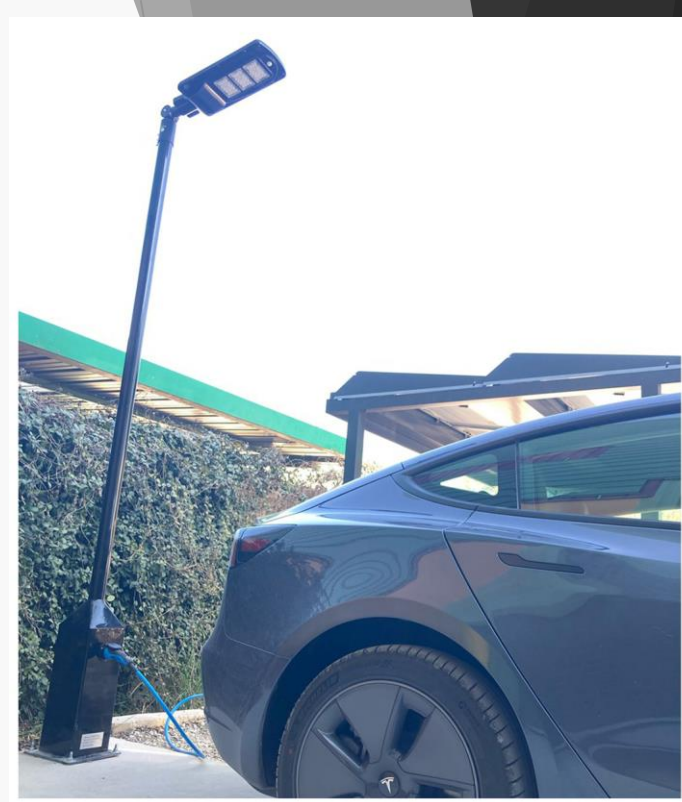
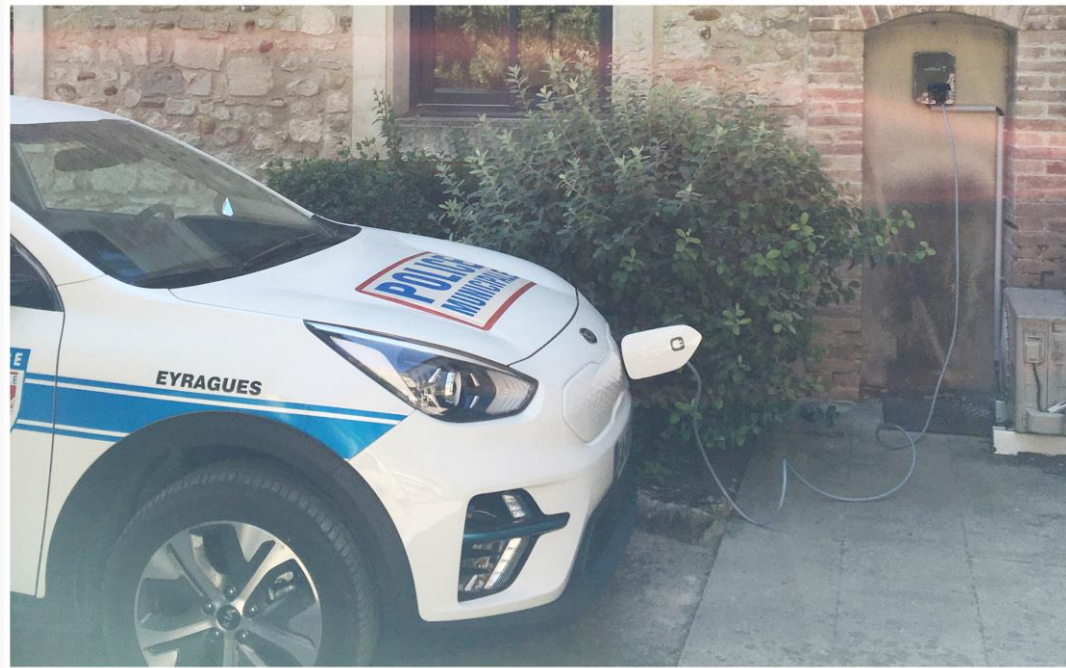



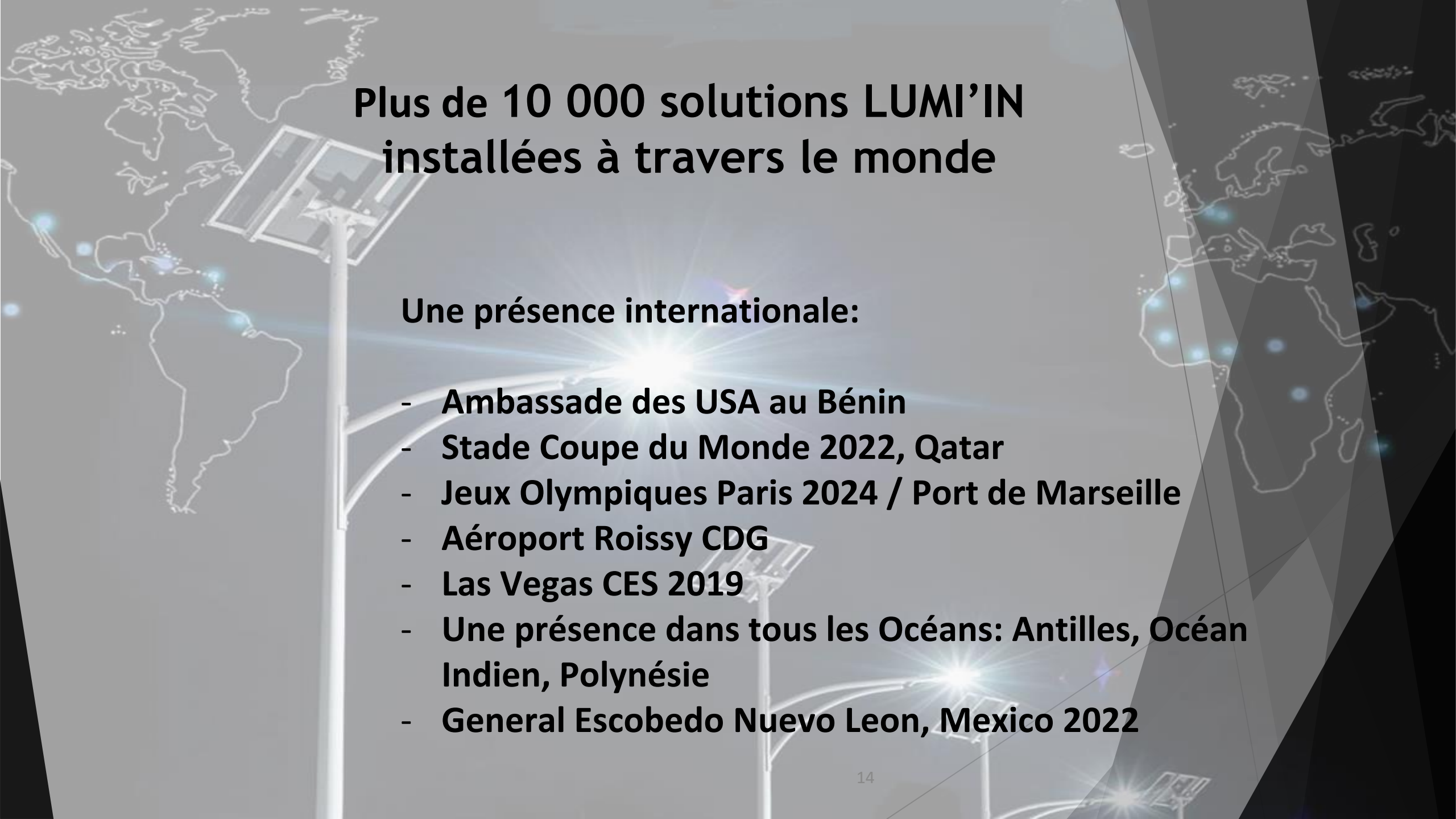

# **Plus de 10 000 solutions LUMI'IN installées à travers le monde**

## **Une présence internationale:**

- **Ambassade des USA au Bénin**
- **Stade Coupe du Monde 2022, Qatar**
- **Jeux Olympiques Paris 2024 / Port de Marseille**
- **Aéroport Roissy CDG**
- **Las Vegas CES 2019**
- **Une présence dans tous les Océans: Antilles, Océan Indien, Polynésie**
- **General Escobedo Nuevo Leon, Mexico 2022**



# Ils font confiance à LUMI'IN



# Prix et communautés

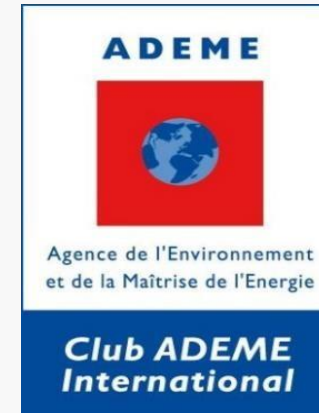

LOW  
CARBON  
BUSINESS  
ACTION  
IN MEXICO



This project is funded  
by the European Union



Merci pour votre attention,  
L'Equipe LUMI'IN reste à votre disposition pour toute information complémentaire

## Contacts LUMI'IN

Siège : Ecoparc de Malijai, 04350 Malijai France

Site de production: 692 route d'Orange, 84870 Loriol du Comtat France

Bureau Export: Lafontaine 32, Polanco, Mexico City, Mexique

Site Web: <https://lumi-in.fr>

Tel: +33 (0) 4 82 79 82 82

Email: [info@lumi-in.fr](mailto:info@lumi-in.fr)

