



FP165 UC HB

	FP160	FP165
Crimping range (mm) ¹⁾	10-202	10-202
Crimping range (inch) ¹⁾	0.39-7.95	0.39-7.95
Max. crimping force (kN)	3500	5000
Max. crimping force (tonnage)	350	500
Number of crimpings/hour ²⁾	1800	1260
Hose size ID (inch)	6	6
Die set ³⁾	P32 ⁵⁾ FP160	P32 ⁵⁾ FP160
Max. opening (mm) ⁴⁾	+125	+125
Master die D/L (mm)	220/116	220/116
Master die D/L (inch)	8.66 / 4.57	8.66 / 4.57
Control	UC	UC
Motor (kW)	5.5	5.5
Motor (HP)	7.5	7.5
SIZE: length (mm)	940 / 600	1060 / 600
width (mm)	860 / 1056	860 / 1056
height (mm)	1780 / 1185	1825 / 1185
SIZE: length (inch)	37. / 23.7	71.8 / 23.7
width (inch)	33.9 / 41.6	33.9 / 41.6
height (inch)	71.9 / 46.7	71.9 / 46.7
Weight (kg)	2000 / 182	2460 / 182
Weight (lbs)	4409 / 402	5423 / 402

Options:
Auto greasing
Die set rack
Oil cooler
Speed adjustment
Remotic control unit
Electric back stop device
Mechanical back stop device
Pinning support mandrel
UC1, UC2, UC3

- 1) With standard dies. Crimping range can be increased with special dies.
- 2) Theoretical with 10 mm cycle
- 3) See table for die set data
- 4) Maximum opening is the total die travel. Add this value to the minimum crimping diameter of the die set used. The result is the maximum opening of the machine with die set in place.
- 5) With adapter dies

Finn-Power FP160 and FP165 models are ideal choices when crimping a variety of sizes and types of assemblies. They are especially suitable for manufacturing large fittings. Their high capacity, flexibility and complementary control options really put these machines in a class of their own. Foot pedal is included as a standard.



FP165 UC



FP160 UC

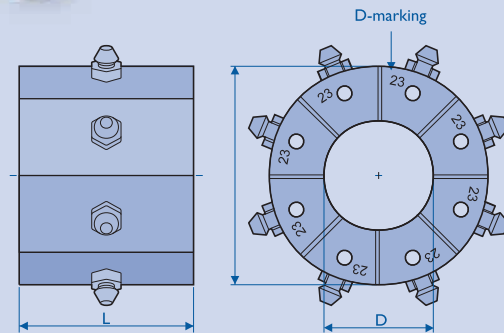

18852/xx
FP160

Pno	Crimping range	D	L
18852/84	84.0 - 92.0	84	116
18852/92	92.0 - 100.0	92	116
18852/100	100.0 - 108.0	100	116
18852/108	108.0 - 116.0	108	116
18852/116	116.0 - 126.0	116	116
18852/126	126.0 - 136.0	126	116
18852/136	136.0 - 146.0	136	116
18852/146	146.0 - 156.0	146	116
18852/156	156.0 - 166.0	156	116
18852/166	166.0 - 178.0	166	116
18852/178	178.0 - 190.0	178	116
18852/190	190.0 - 202.0	190	116

18506/xx
P32

Pno	Crimping range	D	L
18506/10	10.0 - 12.0	10	55
18506/12	12.0 - 14.0	12	55
18506/14	14.0 - 16.0	14	55
18506/16	16.0 - 19.0	16	55
18506/19	19.0 - 22.0	19	55
18506/22	22.0 - 26.0	22	70
18506/26	26.0 - 30.0	26	70
18506/30	30.0 - 34.0	30	70
18506/34	34.0 - 39.0	34	75
18506/39	39.0 - 45.0	39	75
18506/45	45.0 - 51.0	45	90
18506/51	51.0 - 57.0	51	90
18506/57	57.0 - 63.0	57	100
18506/63	63.0 - 69.0	63	110
18506/69	69.0 - 75.0	69	110
18506/74	74.0 - 80.0	74	110
18506/78	78.0 - 87.0	78	110