

# C Series wire rope and strap pullers

1,700 to 4,000 lb capacities

## Cable puller features

- 4:1 design factor for lifting, lowering, and pulling applications; meets ASME B30.21
- Lightweight aluminum frame
- Alloy steel load hook with safety latches
- One-piece cast aluminum drum
- Galvanized, aircraft-quality wire rope
- Ratchet and pawl system provides safe, one-notch-at-a-time lowering
- Cable guide and shield protects wire rope and spools cable evenly
- Reversible handle changes position easily, so pull is always possible against the load

## Strap puller features

Part of the premium C Series, these strap pullers offer the following unique features:

- Increased capacity with smooth, non-marring web strap
- Non-conductive, corrosion-resistant, high-strength synthetic strap will not kink or bind
- Easy payout of strap for fast setup



## C Series Specifications

Model	Capacity lb	Number of Lines	Pull to Lift Rated Load		Cable Diameter in	Min. "A" dist. between hooks in	Lifting Distance ft	Number of Hooks	Shipping Weight with 10' of Lift	
			lb	kg					lb	kg
C400H	1,700	1	57	25.9	1/4	17	20	2	16	7.3
C400H	3,400	2	62	28.2	1/4	22	10	3	16	7.3
C400S	2,000	1	65	29.5	3/32 x 1-7/8	17	12	2	16	7.3
C400S	4,000	2	70	31.8	3/32 x 1-7/8	22	6	3	16	7.3

Dimensions are subject to change.

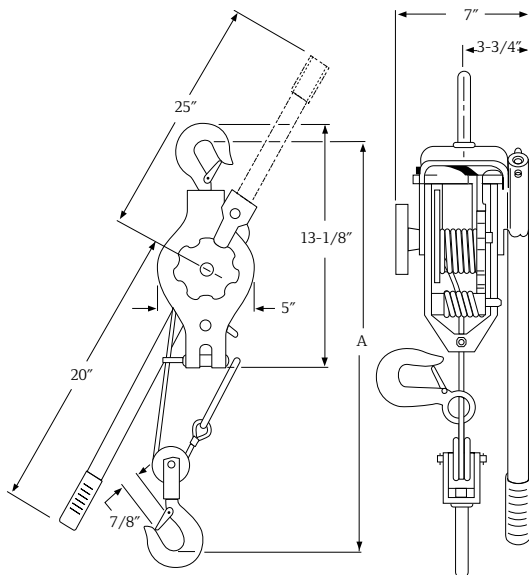

Overload safety handle is designed to bend when an overload is detected. Once the handle begins to bend, additional force will limit the hoist from lifting beyond its capacity.

