



OXBO

Grape Harvesters

A complete family of solutions



**316XL, 3009XL, 3016XL,
3209XL, 6120, 6230, & 6430**

www.oxbo.com



Oxbo grape harvesters

The Oxbo vineyard family offers a complete line of grape harvesters with a model for every vineyard. Oxbo grape harvesters--proudly built in the USA--are designed and manufactured in a state of the art production facility in Lynden, Washington, where machines are built to customer specifications.

building on a legacy

Oxbo continues its legacy by building grape harvesters that consistently deliver high quality fruit without sacrificing in-field productivity.

The Oxbo vineyard line is a story of American built harvesters built by an organization big enough to drive innovation and small enough to build relationships.

Oxbo employees listen to customers and work with the vineyard industry to continually improve equipment and build new solutions.

backed by product support

Oxbo backs all its vineyard equipment with over 50 years of experience designing, engineering, building, and supporting niche market harvesting solutions.

Together with dealers and agents around the globe, Oxbo stands behind every machine with readily available parts and in-field service support.

full product family

With the addition of the model 6120, Oxbo now offers the most comprehensive line of vineyard harvesters with models and options available for every vineyard. With a dedication to fruit quality, Oxbo grape harvesters set the standard in productivity.



316XL tow behind

This tow behind model boasts all the features of a self-propelled harvester including the effective three fan cleaning and a bucket conveyance system proven to deliver high quality fruit. The 316XL also features a high capacity, full-sized picking tunnel to allow it to efficiently handle even high tonnage crops. The 316XL is compatible with a variety of trellis systems.



3009XL & 3016XL dedicated grape & raisin harvesters

The 3000 series has set the standard for economical harvesting performance in North America since the 1990s. Together, the Oxbo three fan cleaning system and the gentle bucket conveyance allows these harvesters to deliver clean, whole fruit. The narrow width of the 3009XL allows it to easily harvest tight row spacings. The 3016XL is also available with dual over-the-row-conveyors for raisin harvest.



3209XL Grape harvester

The Oxbo 3209XL is the only machine designed to efficiently and effectively pick GDC trellises. This three wheeled harvester features a unique head capable of tilting a full 28 degrees with a 64-inch wide picking tunnel. Changing the configuration from GDC to a single curtain is fast and easy. The 3209XL has an extended catching area to allow faster harvesting speeds through the field.



6120 Grape harvester

The Oxbo 6120 is a four wheel dedicated harvester designed to pick the highest quality fruit. The 6120 can handle steep and challenging terrain while the high capacity buckets allow the harvester to deliver high productivity in the field. Available with a broad selection of options, the 6120 can be customized for a wide range of vineyards. The 6120 is also compatible with Oxbo's PremiumSort cleaning system.



6230 Trunk shaker

The 6230 accommodates a full range of trellis configurations with either the Oxbo trunk shaker, the indexing bow rod picking system, or the forced-balance canopy shaking head. This versatile harvester can handle steep and challenging terrain while the high capacity buckets and Oxbo cleaning system consistently deliver the highest quality fruit. The 6230 can also be equipped with a PremiumSort cleaning system.



6430 Multi-crop harvester

The tall tunnel Oxbo 6430 was specifically designed to harvest super high density olives, but has proven equally capable of harvesting wine grapes and other high density crops. The robust chassis and bow rod picking system can handle the demands of olive harvest; the 6430 is also available with a high capacity recycle bin for truly continuous harvesting.

advanced vintage technology™

Oxbo's Advanced Vintage Technology (AVT) system is integrated into every model **to ensure fruit integrity and provide wine control**. Each aspect of the AVT system works together **to deliver more intact, clean fruit to the end sample without sacrificing in-field harvesting productivity**. Oxbo harvested fruit gives the wine maker more control of the wine making process.

Soft-touch picking system

Oxbo's proven soft-touch bow rod picking system was designed for minimal canopy impact. The system **removes intact grapes while reducing juicing and the picking action is easily customized with hydraulic head spread**.

Oxbo's bow rod picking system can be further customized with your choice of bow rods. Oxbo offers three different choices--standard, heavy duty, and extended contact. Each rod delivers dependable in field performance.

Available in the model 6230, the Oxbo trunk shaker system **removes fruit by shaking the trunk and has proven to deliver gentle and effective picking action for a wide range of trellis systems** and vineyard configurations.

The 6230 is also available with a forced balanced canopy shaker to allow it to be used with wood posts and other trellis systems. This build increases the versatility of the 6230.



Vines before harvest



Vines after Oxbo soft-touch bow rod head



Oxbo Soft-touch bow rod head with extended contact rods



Oxbo Forced balance canopy shaker



Oxbo trunk shaker head

fruit integrity. wine control.

High fruit retention catching system

Oxbo grape harvesters are gentle on vines without sacrificing fruit retention.

Oxbo offers various catcher configurations to meet the unique needs of different vineyard operations. All Oxbo grape harvesters now come standard with nylon catchers. The unique construction of Oxbo catchers provides long life in the field.

To configure your catcher performance, Oxbo offers both a softer spring catcher and more aggressive closing torsion block.



High capacity bucket conveyance

Since the market introduction, Oxbo's bucket conveyance has been a point of difference, driving capacity without sacrificing fruit quality. The Oxbo bucket design retains free run juice, ensuring you capture all of your harvest.

Today's buckets are made from high quality materials for long life. Oxbo buckets are designed to carry your fruit, not drag it. This allows Oxbo to consistently deliver the highest quality fruit. Oxbo buckets also offer independent speed control for improved performance across yield levels.



Unique three fan cleaning system

Oxbo's industry-leading three fan cleaning system continues to set the standard for MOG removal. The fan system has proven most effective at removing debris and MOG. at three unique directional transition areas.

Cleaning the grape at these transition areas, allows Oxbo fans to easily remove leaves and other debris





PREMIUMSORT

easy by-pass. high capacity. simple operation. capable of straight-to-tank.

PremiumSort Process:

1. Leaves are removed using Oxbo's three-fan cleaning system.



2. Grape clusters are destemmed and the remaining rachis is discarded evenly into the vineyard.



3. Grapes, petioles and jacks are sorted using a food safe, modular belt designed for longevity and breakage resistance even when encountering typical vineyard debris. Whole grapes and juice pass through the sorting belt while petioles, jacks, leaf fragments, and other MOG remain on the belt surface.



4. Petioles, jacks and leaf fragments are fed into an auger and then discharged from the harvester.

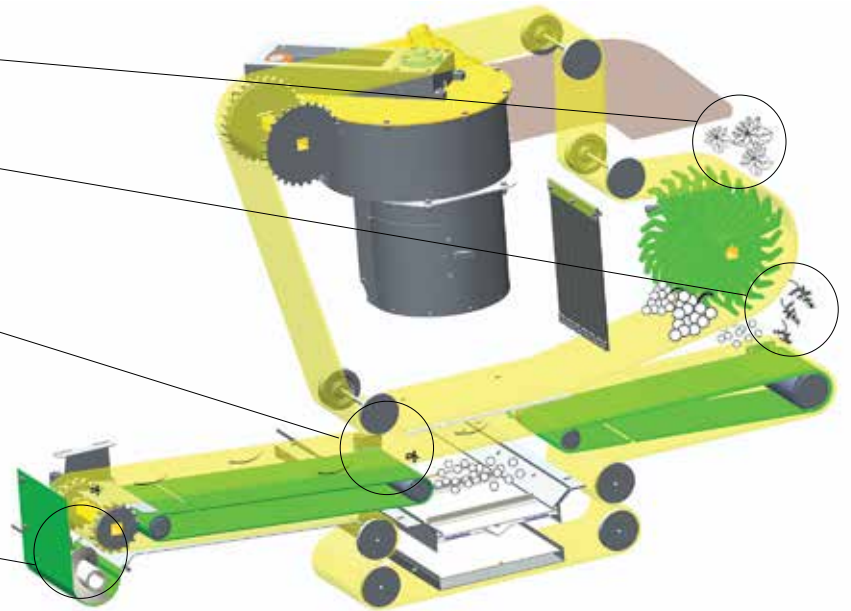

PremiumSort Features

- *Straight-to-Tank Quality*
- *High capacity*
- *Easy by-pass*
- *Easy operation*
- *Patented sorting technology*

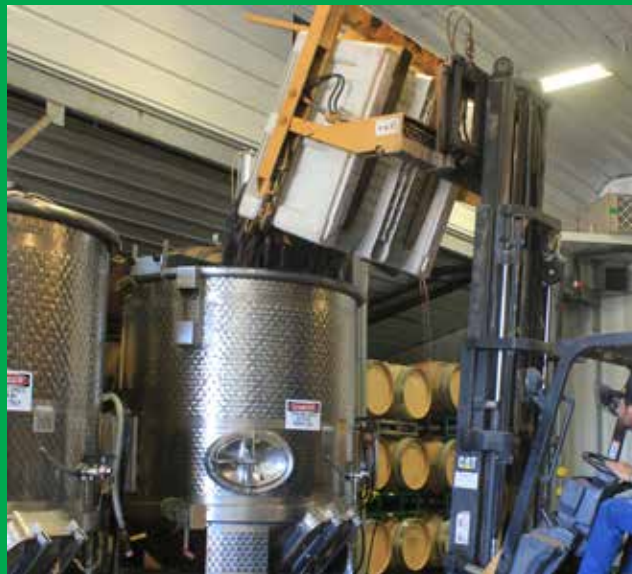



FLEETCOMMAND

With the integration of FleetCommand on the 6120, 6230 and 6430 harvesters, Oxbo provides you with the information needed to optimize your fleet of grape or olive harvesters. FleetCommand gives machine owners and managers remote access to up-to-date harvester data including:

- Machine setting information
- Harvest information
- Machine location and turn-by-turn directions
- Customized alerts
- Customized reporting

FleetCommand was *designed to optimize your harvester performance* and can be accessed on your Smartphone, tablet, laptop or desktop.

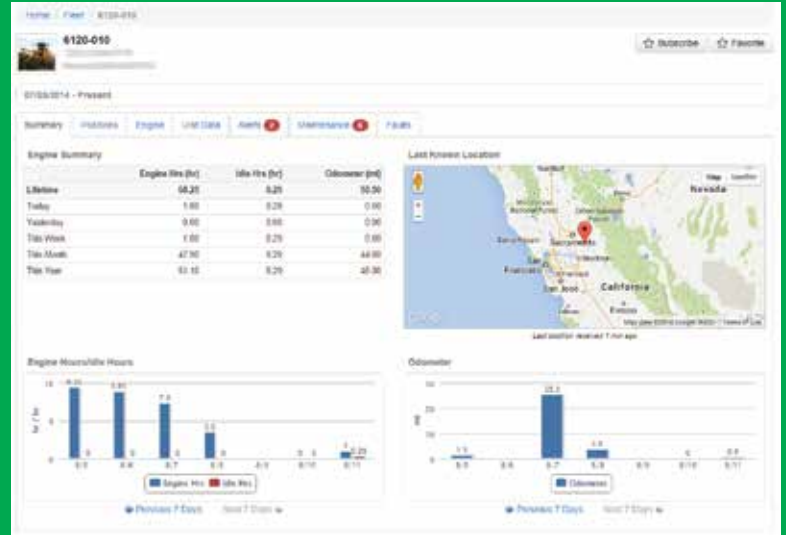

View of FleetCommand portal from a laptop



YIELDTRACKER

Oxbo YieldTracker is now available on all Oxbo grape and olive harvesters. YieldTracker is Oxbo's solution to allow customers to produce yield maps to help them gain insight on yield distribution throughout the vineyard or orchard. These maps can lead to actionable insights which can be used to positively impact vineyard operations.

Oxbo's Yield Tracker is now available on all new Oxbo grape and olive harvesters and as a retro-fit kit on existing machines.



Key Oxbo Harvester Features

Low mounted engine

The low mounted engine delivers easy maintenance, excellent stability, and reliable performance season after season.

Center mounted cab

On models equipped with a cab option, Oxbo's air conditioned cab sits directly over the picking tunnel. The cab placement gives the operator a clear view of the canopy, enabling better performance and better visibility.

All-wheel hydrostatic drive system

The efficient ground drive system delivers stability and control, even in challenging terrain. On the four-wheeled 6000 series harvesters, this ground drive system allows the machines to easily handle steep grades and difficult field conditions. With up to 30-inches of harvester lift, these models also outperform the competition in side slope or terraced vineyards.

Fully customizable discharge options

Oxbo grape harvesters can be built with several discharge options. Oxbo's standard over-the-row conveyor (OTRC) gives continuous productivity in the field. The OTRC can be further customized to facilitate fruit discharge into standard gondolas or bins. The Oxbo 3016XL can be built with both a left and right OTRC for use in continuous tray raisin harvesting.

Recycle bins and combination configurations (right OTRC, left dump bin) are also available to improve harvest productivity and achieve truly continuous harvesting.

Some Oxbo harvesters can be configured with double dump bins for onboard storage.



Comfortable cab interior



Oxbo double OTRC design for continuous tray raisin harvesting







Specifications				
	3016XL	3009XL	3209XL	316XL
Length:	16ft 11in (5.16m)			17ft 4in (5.286m)
Width:	10ft (3.05m)	8ft 10in (2.69m)	11ft 8in (3.56m)	10ft (3.05m)
Minimum Height:	11ft 9in (3.58m)		12ft 8 in (3.86m)	11ft 9in (3.58m)
Tunnel Width:	2ft 6in (0.76m)		5ft 3in (1.6m)	
Lift:	24in (0.61m)			24 in (0.61m)
Weight:	15,000lbs (6,800kg)	13,000lbs (5,900kg)	16,700lbs (7,600kg)	10,600lbs (4,800kg)
Tires				
Front tire size:	360/70R20			NA
Rear tire size:	420/70R28			16.9-24 Turf
Optional rear tires:	600/55-26.5			16.9-26R1
Engine				
Engine:	John Deere 4045 turbo charged Tier III, 100hp			N/A
Other Specifications				
Transmission:	Danfoss 46 series			N/A
Final Drives:	Fairfield W5 rear, Fairfield W1 front			Fairfield 7000
Hydraulics:	Danfoss 75cc pump			Danfoss 75cc pump

Specifications may vary with option selection; all specifications are subject to change without notice.



Harvester Options

All Oxbo grape harvesters are configured and built to customer requirements. The fully customizable harvesters allow owners to select the specific options to match their harvest conditions.

Catcher Choices

- Long-life nylon catchers and springs
- Torsion blocks with sweptback angle, long-life nylon catchers

Bow Rod Choices

- Standard bow rods
- Extended contact bow rods
- Heavy duty bow rods

Fruit Discharge Choices

- Second over-the-row conveyor
- Double Dump Bins
- Recycle bin
- Gondola discharge chute
- Trailer discharge chute
- Magnet cleaner(s)

Other Optional Choices

- Brake steer system
- Posi-traction
- Rear catwalk
- Rear ladder
- Remote greasing
- Auto height control
- Food grade oil
- Cruise control
- PremiumSort

6120	6230	6430
17ft 8in (5.38m)	21ft (6.4m)	
9ft 10in (3m)	11ft 11in (3.63m)	11ft 11in (3.63m)
12ft (3.66m)	12ft 10in (3.91m)	14ft 2in (4.32m)
2ft 6in (0.76m)	4ft 6in (1.37m)	4ft 6in (1.37m)
26in (0.66m)	30in (0.76m)	
20,800lbs (9,400kg)	23,500lbs (10,700kg)	26,000lbs (11,800kg)
420/70R24	440/65R24	
420/70R28	19.5LR24	
	600/55 -26.5	
John Deere 4045 turbo charged Tier III, 140hp	CAT turbo charged Tier 4F, 174 hp	
Danfoss H1 tandem		
Auburn		
Danfoss 147cc pump		

*not all options are available on all models.





Oxbo International
270 Birch Bay
Lynden Road
Lynden, WA 98264

tel 360.354.1500
888.656.7826

Visit our website:
www.oxbo.com
or scan the QR code
to learn more about
the Oxbo Vineyard
Equipment

