



Installation and Operation

Humidifiers for Air Handling Systems

AM-90M, -91M, -92M, -1200M, -93M, -1300M, -94M, -1400M;
 HEM-90M, -91M, -92M, -1200M, -93M, -1300M, -94M, -1400M;
 DSA-90, -91, -92, -93

Table of Contents

	Page
Preliminary Procedures.....	2
Do's and Don'ts of Humidifier Installation.....	3
Methods of Installing Humidifier.....	4
Installing and Piping the Humidifier	8
Multiple Manifolds	9
Pneumatic Piping for Air Operated Models	10
Wiring for Electrically Operated Models.....	11
Operation and Servicing	13

Steam humidifiers (or other products) should be installed in locations that allow routine inspection and accessibility for maintenance operations. Armstrong recommends that steam humidifiers not be placed in locations where unusual instances of malfunction of the humidifiers or the systems might cause damage to non-repairable, irreplaceable, or priceless property.

Preliminary Procedure and Manifold Installation

These instructions cover the installation of the models listed below:

Air Operated (AM):

90 - 94 Sizes (Cast Iron)

1200 - 1400 Sizes (Stainless Steel)

Electric Motor Operated (HEM):

90 - 94 Sizes (Cast Iron)

1200 - 1400 Sizes (Stainless Steel)

Electric "On-Off" (DSA):

90 - 93 Sizes (Cast Iron)

Preliminary Procedure

STEP 1: Check Shipment Against Packing List. All components are listed on the packing slip. Report any shortages **immediately**. If the humidifier or accessories have been damaged in transit, notify us and file claim with the transportation company.

If your order covers more than one unit, separate each complete unit. Humidifier tagging and manifold tagging will be the same as shown on the packing list. Model, Serial Number, Steam Pressure, Orifice and Orifice Restriction (if any) are on the metal plate on the humidifier body. Operator for electric motor operated unit is shipped separately but marked with the serial number of the humidifier with which it must be used. Be sure serial numbers agree.

STEP 2: Spot Humidifier Locations. Locate each humidifier according to the engineer's layout or as indicated by your Armstrong Representative. If you must locate the humidifiers yourself, be sure to read and observe the "Do's and Don'ts" on the following page.

Manifold Installation

STEP 3: Cut Hole in Duct or Plenum for Manifold. Use manifold dimensions "X" and "Y" from Table 2-2, below, and add approximately 1/4" for manifold clearance. If multiple manifolds are used, read page 9 first.

STEP 4: Insert Manifold in Duct. Outlet holes must point upstream into air flow, **except on insulated manifolds point discharge holes downstream**. Where manifold is positioned horizontally, use a spirit level. Manifolds longer than one foot should be supported. Put the two piece manifold escutcheon plate in position. When supporting the manifold on the far end allow for manifold expansion and contraction of 1/2" - 1".

Instructions continued on page 8

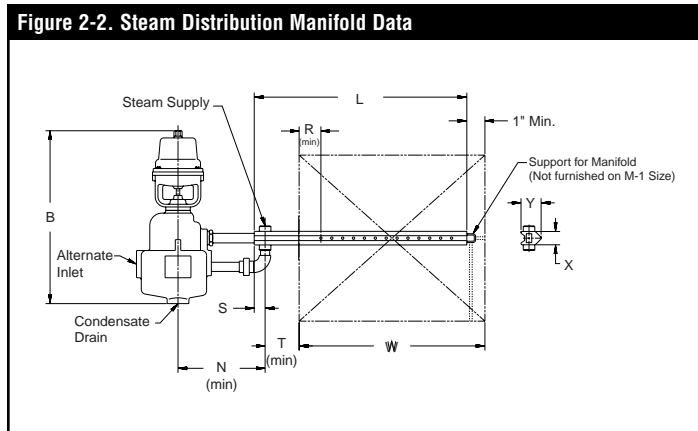
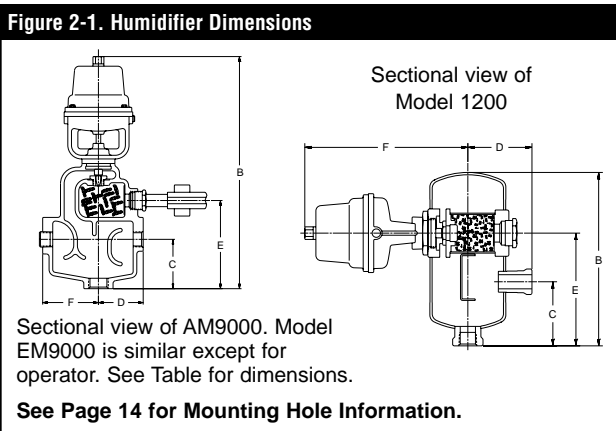

Table 2-1. Dimensions in Inches

Model No.	B	C	D	E	F
AM-90	8 7/8	—	2 3/8	2 7/16	2 13/16
HEM-90	15 1/2	—	2 3/8	2 7/16	2 13/16
DSA-90	7	—	2 3/8	2 7/16	2 13/16
AM-91	16	3 3/8	3 1/16	6 1/16	3 13/16
HEM-91	19 1/2	3 3/8	3 1/16	6 1/16	3 13/16
DSA-91	10 7/8	3 3/8	3 1/16	6 1/16	3 13/16
AM-92	16	3 3/8	3 13/16	6 1/16	3 13/16
HEM-92	19 1/2	3 3/8	3 13/16	6 1/16	3 13/16
DSA-92	10 7/8	3 3/8	3 13/16	6 1/16	3 13/16
AM-1200	10 3/8	3 13/16	3 13/16	6 11/16	9 11/16
HEM-1200	10 3/8	3 13/16	3 13/16	6 11/16	13 1/4
AM-93	19 1/8	4 5/8	4 3/4	9	4 3/4
HEM-93	22 3/4	4 5/8	4 3/4	9	4 3/4
DSA-93	14 1/2	4 5/8	4 3/4	9	4 3/4
AM-1300	16 3/4	6	5 9/16	10 5/16	10 5/16
HEM-1300	16 3/4	6	5 9/16	10 5/16	14 3/16
AM-94	23 1/2	6 7/8	8	12 5/8	8
HEM-94	28 1/2	6 7/8	8	12 5/8	8
AM-1400	24 5/8	8 15/16	8 5/16	14 11/16	12
HEM-1400	24 5/8	8 15/16	8 5/16	14 11/16	16 1/2

Table 2-2. Cross-Section Dimensions

Model	"N"	"R"	"S"	"T"	"X"	"Y"	Steam Supply	Condensate Drain	Alternate Inlet
90 Size	5 3/8"	2"	1"	1"	1 1/4"	1 7/8"	1/2" NPT	1"	1/2"
91 Size	5 11/16"	2"	1"	1"	1 1/4"	1 7/8"	1/2" NPT	1"	3/4"
92 Size	8 9/16"	2"	1"	1"	1 3/4"	2 5/8"	3/4" NPT	1"	3/4"
1200 Size	8 9/16"	2"	1"	1"	1 3/4"	2 5/8"	3/4" NPT	1"	3/4"
93 Size	9 1/8"	2"	1 5/8"	1 5/8"	2 1/8"	3 1/8"	1 1/4" NPT	1 1/4"	1 1/4"
1300 Size	9 7/8"	2"	1 5/8"	1 5/8"	2 1/8"	3 1/8"	1 1/4" NPT	1 1/4"	1 1/4"
94 Size	13 1/2"	2"	1 5/8"	1 5/8"	3 3/4"	4 1/4"	2" NPT	2"	2"
1400 Size	14 5/16"	2"	1 5/8"	1 5/8"	3 3/4"	4 1/4"	2" NPT	2"	2"

Table 2-3. Manifold Lengths and Duct Widths With Which They May Be Used

Manifold Model No.	M-1	M-1.5	M-2	M-3	M-4	M-5	M-6	M-7	M-8	M-9	M-10	M-11	M-12
(L) Length	12"	18"	24"	36"	48"	60"	72"	84"	96"	108"	120"	132"	144"
W - Duct (Min)	8"	15"	21"	31"	43"	53"	65"	77"	89"	101"	113"	125"	137"
Width (Max)	14"	20"	30"	42"	52"	64"	76"	88"	100"	112"	124"	136"	148"

NOTE: Insulated manifolds available. Consult factory.

Table 2-4. Model 90 Manifold Lengths and Duct Width With Which They May Be Used

Vertical Air Flow No.	MV-1	MV-1.5	MV-2	MV-3	MV-4	MV-5	MV-6	MV-7	MV-8	MV-9	MV-10	MV-11	MV-12
Horizontal Air Flow No.	MH-1	MH-1.5	MH-2	MH-3	MH-4	MH-5	MH-6	MH-7	MH-8	MH-9	MH-10	MH-11	MH-12
(L) Length	12"	18"	24"	36"	48"	60"	72"	84"	96"	108"	120"	132"	144"
W - Duct (Min)	8"	15"	21"	31"	43"	53"	65"	77"	89"	101"	113"	125"	137"
Width (Max)	14"	20"	30"	42"	52"	64"	76"	88"	100"	112"	124"	136"	148"

Do's and Don'ts of Humidifier Location and Installation

All recommendations for the application of Armstrong Humidifiers are based on tests and field experience. However, they are based on duct air velocities and temperatures that are most commonly encountered, and the recommendations may have to be modified when velocities are very high and/or temperatures unusually low. We also

reserve the right to modify recommendations without notice if subsequent tests or experience indicate that a change should be made. For these reasons, we urge that you check all applications with your Armstrong Representative before installation.

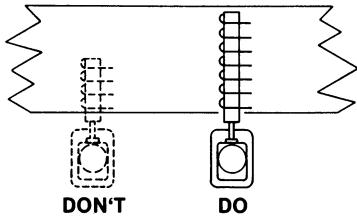

Fig. 3-1. Always select the steam distribution manifold length that will span the maximum width of duct.

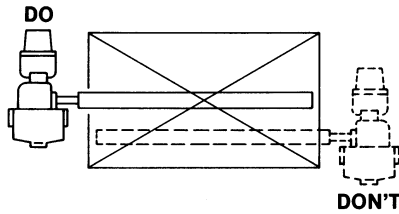

Fig. 3-2. When possible, install the steam distribution manifold into the center of duct.

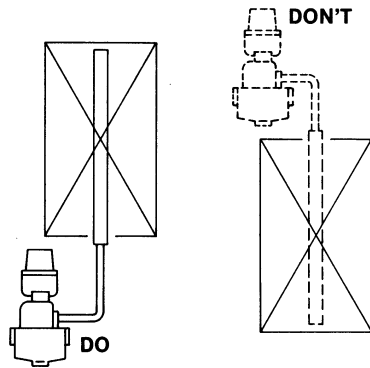

Fig. 3-3. Manifold should never be installed vertically downward from control valve. This presents a condensate drainage problem in the jacket of the manifold. Vertically upward installation is permissible.

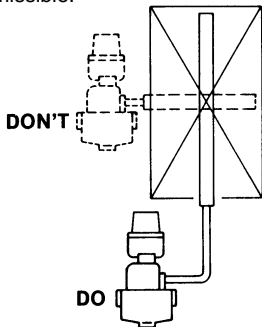

Fig. 3-4. Always size and install dispersion manifold to span the widest dimension of the duct section.

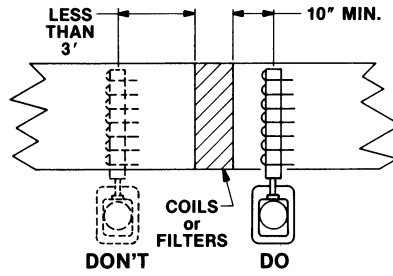

Fig. 3-5. Whenever possible, install distribution manifold downstream from coils. If more than 3' of distance between manifold and coil on upstream side is available, it is permissible to install at this location.

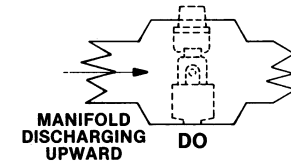
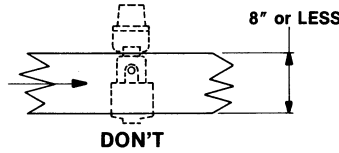

Fig. 3-6. Do not restrict air flow in ducts 8" or less in depth. Utilize an expanded section.

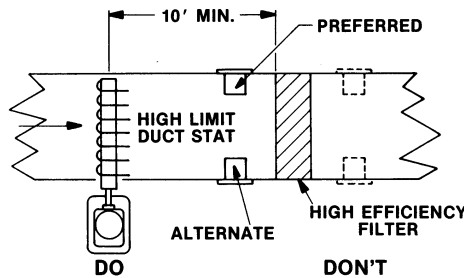

Fig. 3-7. Do not install the distribution manifold less than 10' upstream from a high efficiency filter. Locate high limit duct humidity controller immediately upstream from the filter.

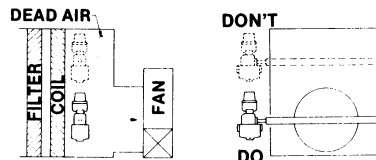

Fig. 3-8. When it is necessary to place humidifiers in coil section ahead of fan, locate manifold in most active air flow and as far upstream from fan inlet as possible.

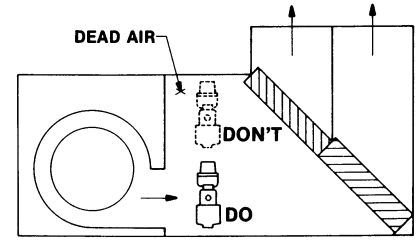

Fig. 3-9. When it is necessary to place humidifier discharge into a "packaged" multi-zone air handling system, install distribution manifold into center of active air flow and as close to fan discharge as possible.

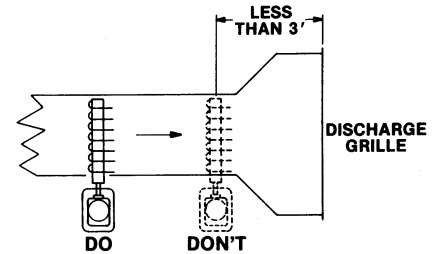

Fig. 3-10. Always install distribution manifold as far upstream from a discharge air grille as possible—never less than 3'. This also applies to elbows, splits, transitions, ducts, etc.

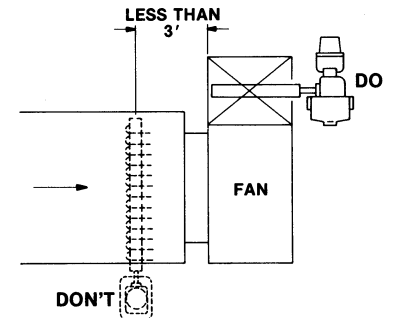

Fig. 3-11. Dispersion manifold should never be placed within 3' of an air fan intake. The desirable location would be at the fan discharge.

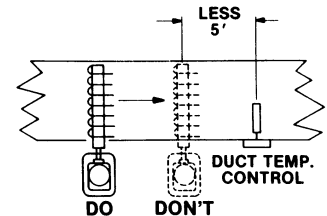

Fig. 3-12. Do not install manifold closer than 5' upstream of temperature controller.

Methods of Installing Humidifiers

The standard method of installing Armstrong humidifiers is with the humidifier body vertical (**do NOT mount body horizontally**) and the manifold discharging into the air flow. For operator orientation see manufacturer's data. Pipe and

fittings indicated by dotted lines are furnished by installing contractor. Dimensions and pipe sizes are given in Tables 8-1 and 8-2 on Page 8.

Primary Methods of Installation

May be used with 91 - 94 Cast Iron, and 1200 - 1400 Stainless Steel Humidifiers

Figure 4-1. Horizontal Installation

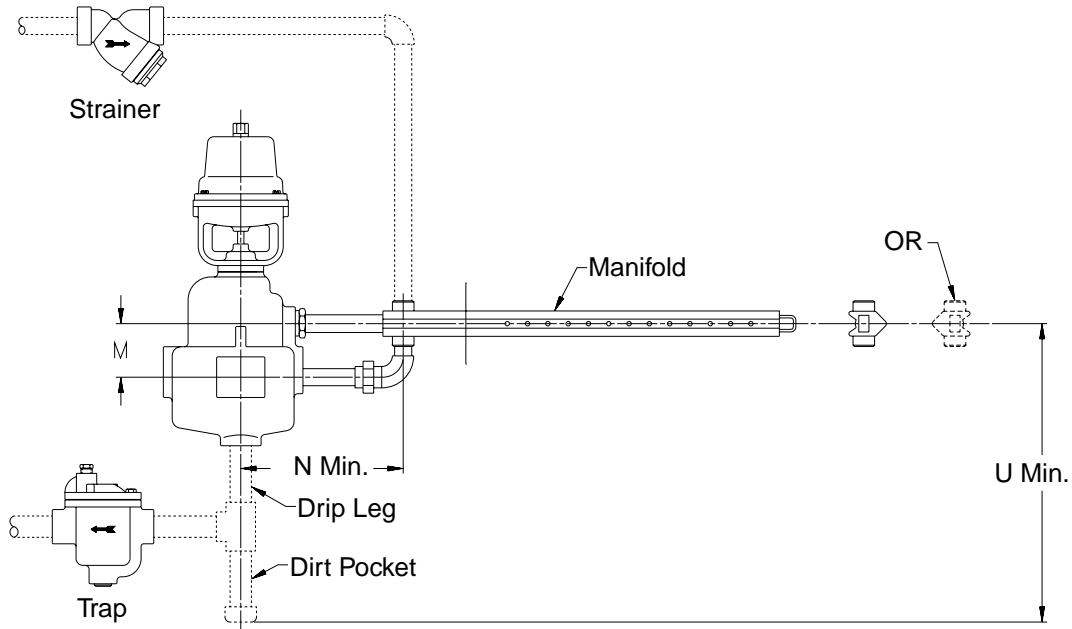
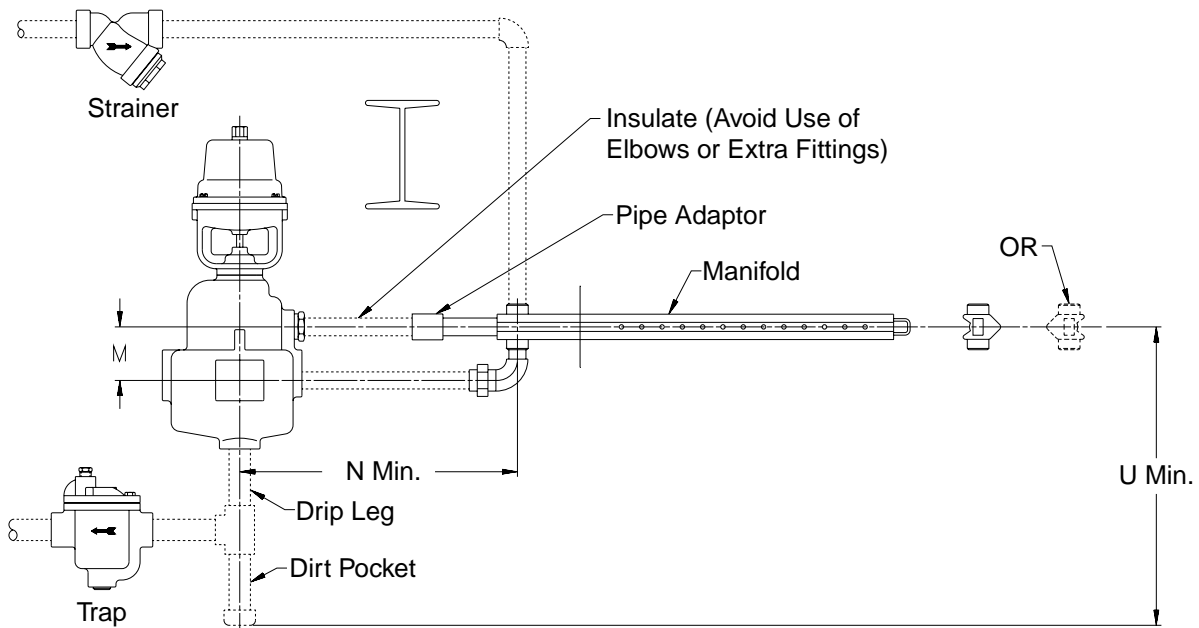

Figure 4-2. Installation Method Where Obstructions Prevent Direct Manifold Connection



Note: Maximum distance recommended from humidifier to manifold is 5-10 feet.

Figure 5-1. Installation Detail for Horizontal Manifold Installation in Vertical Air Flow Ducts

Dimensions and pipe sizes are given in Tables 8-1 and 8-2 on Page 8.

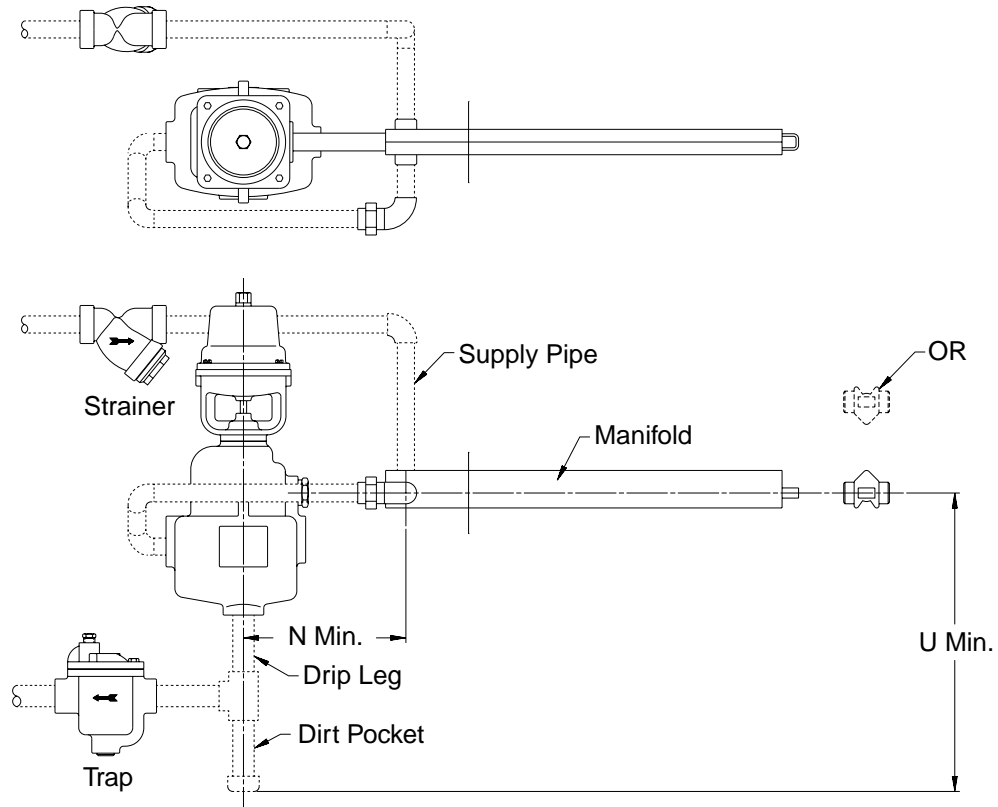

Figure 5-2. Installation Method Where Vertical Manifold Installation is Required

Dimensions and pipe sizes are given in Tables 8-1 and 8-2 on Page 8.

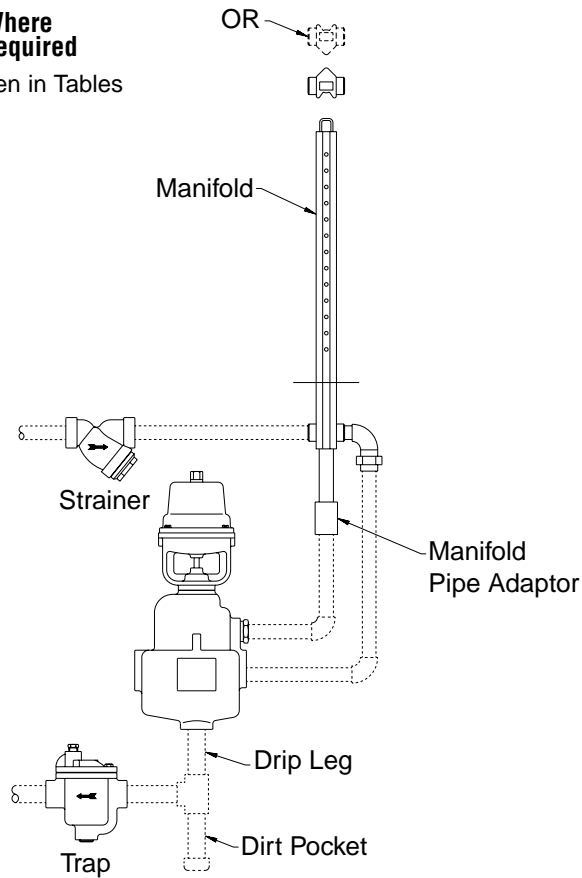

Figure 6-1. Model 90 Installation Method

Dimensions and pipe sizes are given in Tables 8-1 and 8-2 on Page 8.

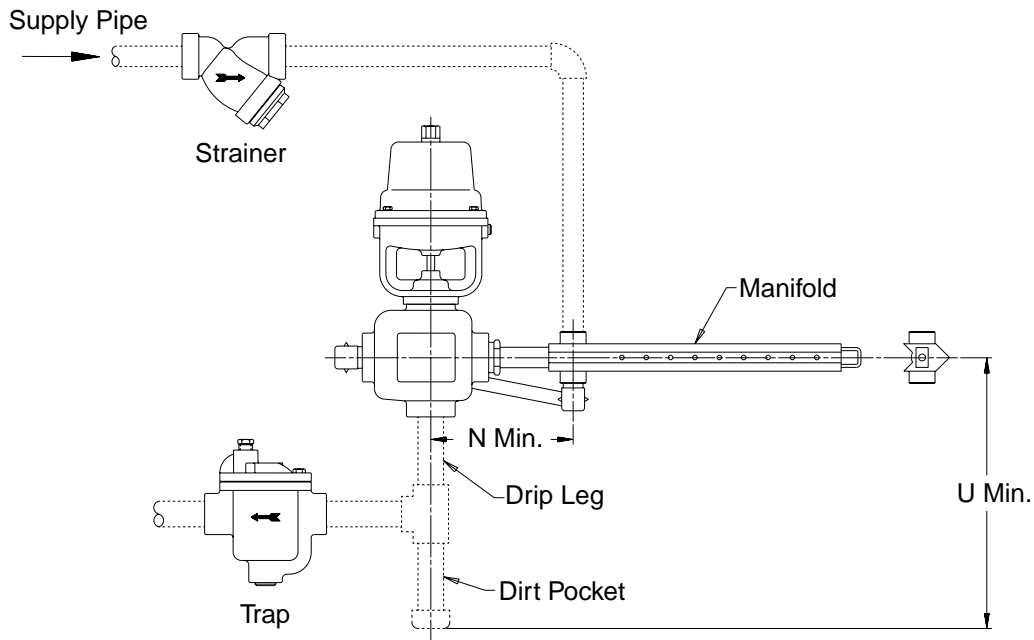
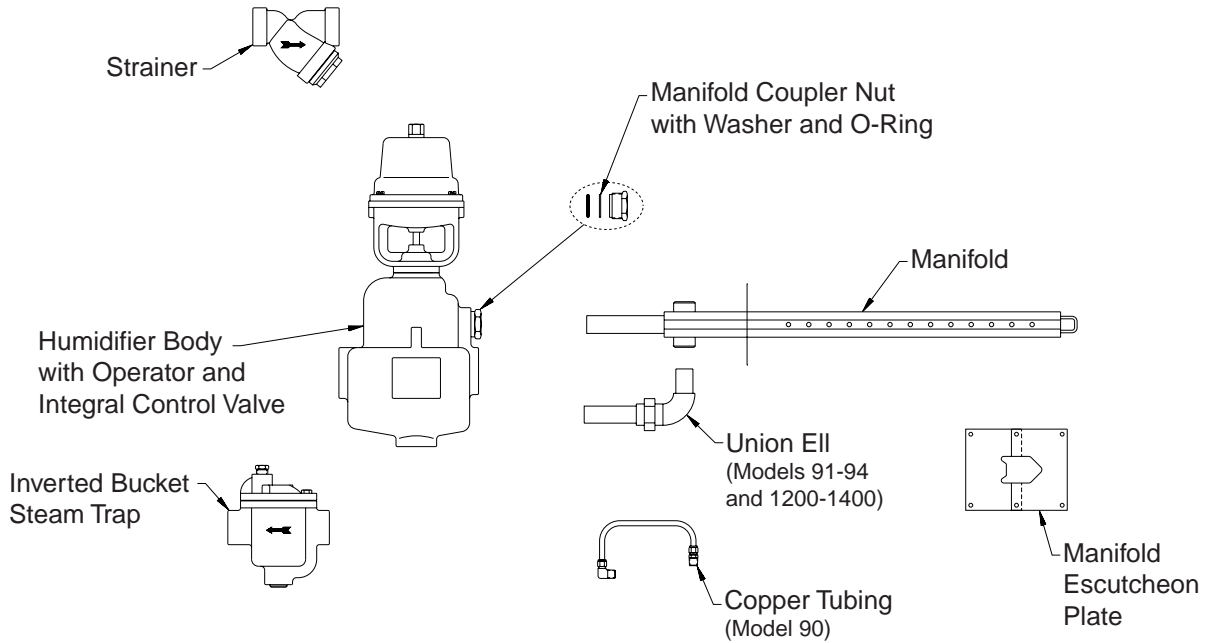

Figure 6-2. Components Furnished as Part of a Standard Single Manifold Installation

Dimensions and pipe sizes are given in Tables 8-1 and 8-2 on Page 8.



Alternate Method of Installation

Figure 7-1. Vertical Installation

Dimensions and pipe sizes are given in Tables 8-1 and 8-2 on Page 8.

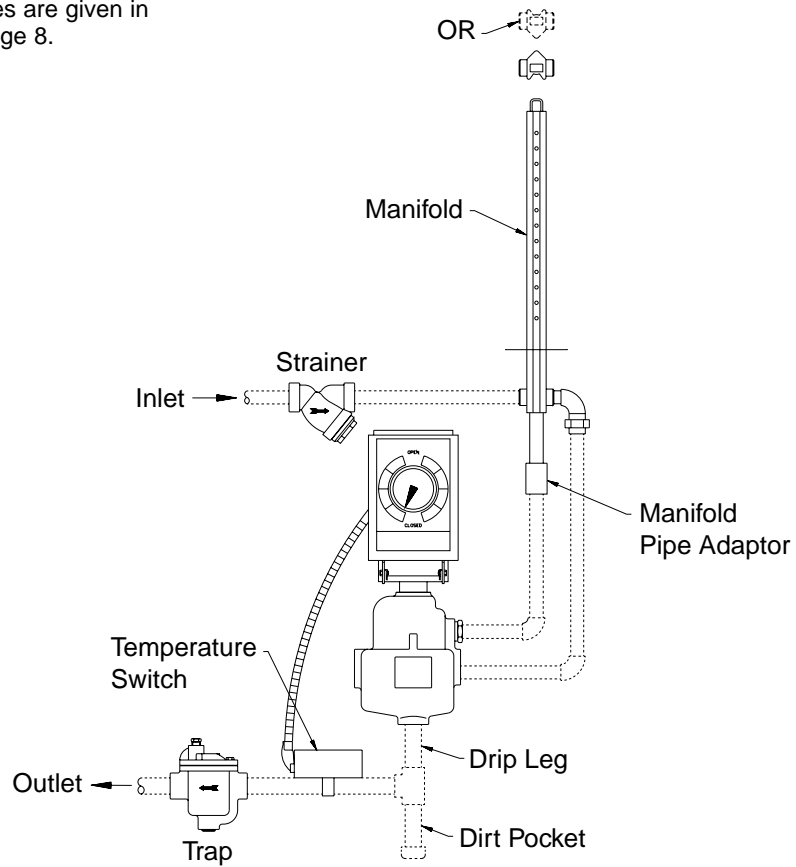

Figure 7-2. Connection size and dimensions of manifold with pipe adaptor

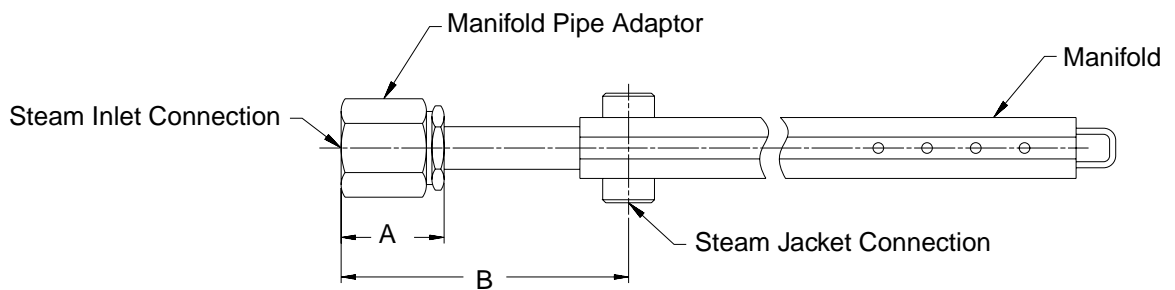

Chart 7-1.				
Manifold Size	Manifold Steam Jacket Conn. Size	Pipe Adapter Connection Size	A	B
90	1/2" NPT	1/2" NPT	2 1/8"	4 1/2"
91	1/2" NPT	1/2" NPT	2 1/8"	4 1/2"
92/1200	3/4" NPT	3/4" NPT	2 1/8"	8 3/4"
93/1300	1 1/4" NPT	1" NPT	2 3/8"	8 3/4"
94/1400	2" NPT	2" NPT	3 1/2"	10"

Installing and Piping the Humidifier

STEP 5: Provide Support for Humidifier Body

Suspension from the ceiling is usually best. In all models except 90 and 91 sizes, there are flanged holes near the top of the humidifier body for mounting purposes. See drawing on Page 14.

Table 8-1. Basic Dimensions of Installation Methods
Shown in Figure 5-1 and 5-2.

Humidifier Size	M	N Min.	U Min.
90 or DSA-90-M	-	5 ³ / ₈ "	10"
91 or DSA-91-M	2 ⁵ / ₈ "	5 ¹ / ₁₆ "	13 ¹ / ₄ "
92/1200 or DSA-92-M	2 ³ / ₄ "	8 ⁹ / ₁₆ "	13 ¹ / ₄ "
93/1300 or DSA-93-M	4 ⁷ / ₈ "	8 ⁹ / ₁₆ "	24"
94/1400	5 ⁵ / ₈ "	12 ¹ / ₂ "	28"

STEP 6: Bring Steam Supply to the Manifold as shown in drawings at right. Be sure steam supply corresponds to pressure stamped on humidifier. Do NOT use smaller pipe sizes than shown in the table below for any connections. Take steam supply line from the top of the supply main—**never** from the side or bottom. See Steam Pipe Capacities on Page 14.

Expansion and Contraction. With average length of supply line, the dimension change from hot to cold should not exceed 2". Provide piping with 3 elbows to get swing to take care of expansion and contraction.

Table 8-2. Recommended Pipe Size

Humidifier Size	Supply Header to Strainer	Strainer to Manifold Inlet	Manifold to Body	Drip Leg	Trap Piping
90 or DSA-90-M	1/2"	1/2"	1/2"	1"	1/2"
91 or DSA-91-M	3/4"	1/2"	1/2"	1"	3/4"
92/1200 or DSA-92-M	*3/4"	3/4"	3/4"	1"	3/4"
93/1300 or DSA-93-M	*1 1/4"	1 1/4"	1 1/4"	1 1/4"	3/4"
94/1400	2"	2"	2"	2"	3/4"

*When steam supply is less than 5 psi use one pipe size larger.

Note: Pitch supply piping to humidifier, 1/2" in 10 feet.
Drain and trap runouts exceeding 30 feet in length.
Avoid sags in piping.
Ream pipe and blow out at full steam pressure before connecting to humidifier.

STEP 7: Connect Manifold to Humidifier as shown at the left for the installation method you are using., Piping shown in dotted lines is provided by the contractor. Unthreaded pipe, size as per above, is used with the slip fitting on body. Do not insert manifold or pipe more than 1.5" into body as measured from face of manifold coupler nut. See Figure 9-1.

STEP 8: Install Drip Leg and Armstrong Inverted Bucket Steam Trap. Connect to low pressure return. **NEVER** connect to return line carrying condensate from high pressure traps.

Steam Supply and Condensate Drainage Piping for the Armstrong Humidifier

Figure 8-1. Typical Runout at End of Header

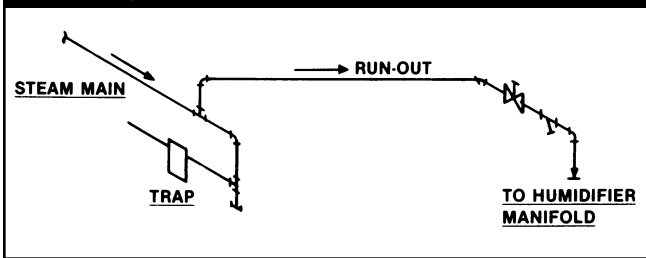

Figure 8-2. Long Runout

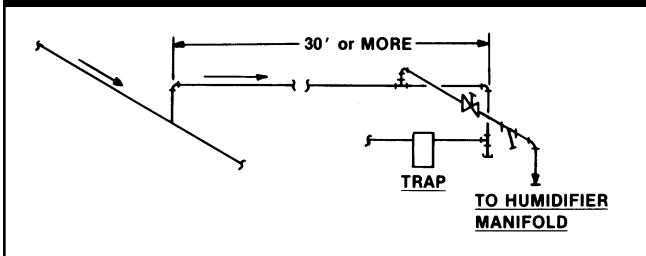

Figure 8-3. Runout with Pressure Reducing Valve

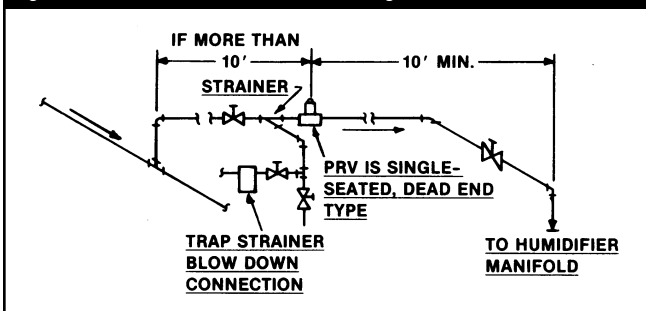

Figure 8-4. Single Runout to Multiple Humidifiers

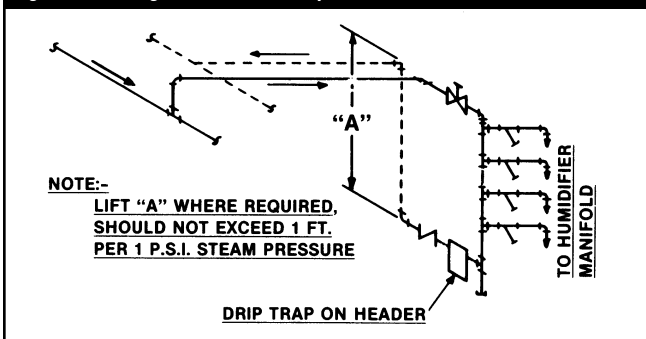
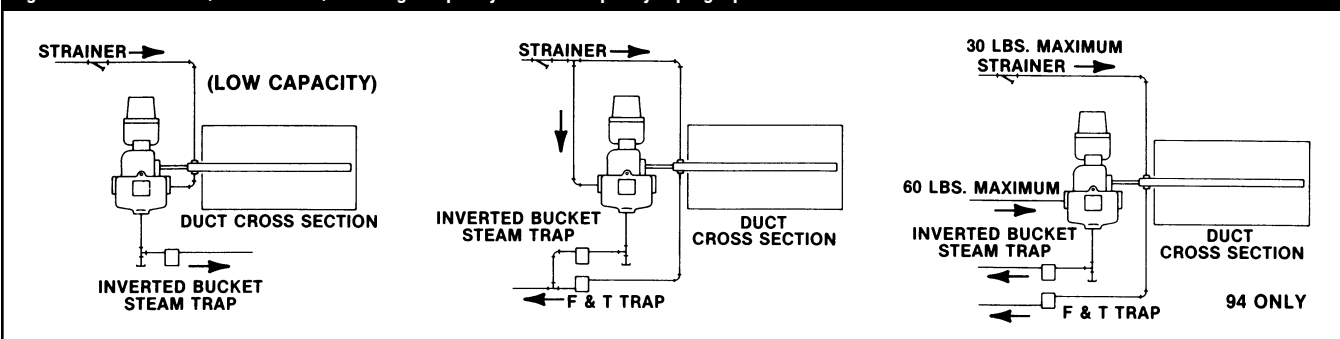

Figure 8-5. Models 93/1300 and 94/1400 High Capacity vs. Low Capacity Piping Options



Multiple Manifolds

Multiple Manifolds – See Page 7 for required pipe sizes and dimensions of manifolds with pipe adapter.

Piping Multiple Manifolds – Figure 9-3 below shows the standard installation of reduced size manifold. Note the steam jacketing is trapped separately and the steam discharge is into a tee, not a cross. A cross will cause uneven steam distribution from manifold to manifold.

Figure 9-1. Pipe Connection at Humidifier

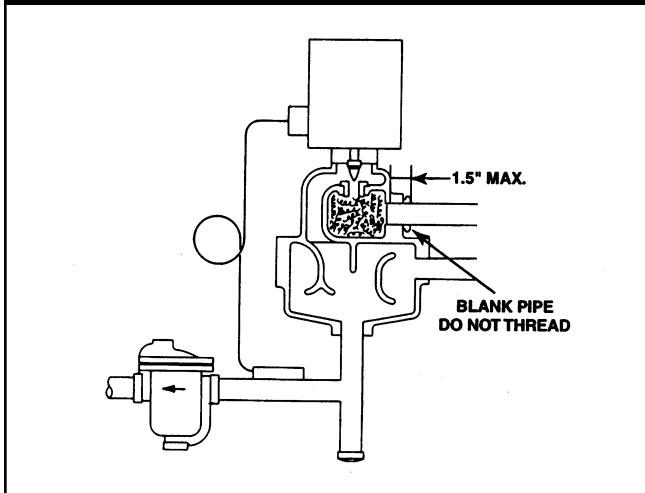

Figure 9-2. Manifold Pipe Adaptor

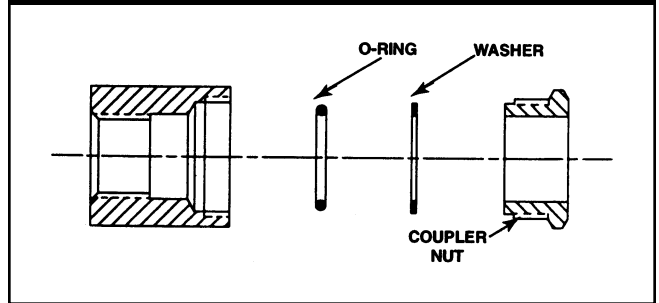

Chart 9-1. Header Size of Manifold Piping Out of Humidifier

Separator Size	Minimum Pipe Size	Suggested Header Size
90	1/2"	3/4"
91	1/2"	2"
92/1200	3/4"	2 1/2"
93/1300	1"	3"
94/1400	2"	5"

Humidifier discharge piping, even with reduced sized manifolds must be as shown.

Figure 9-3. Piping of Reduced Size Manifolds

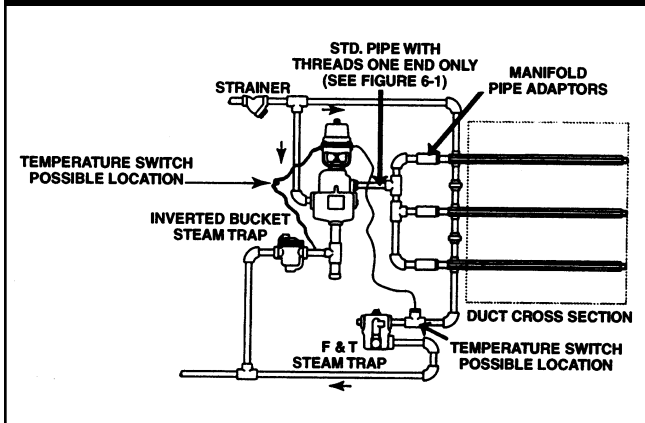
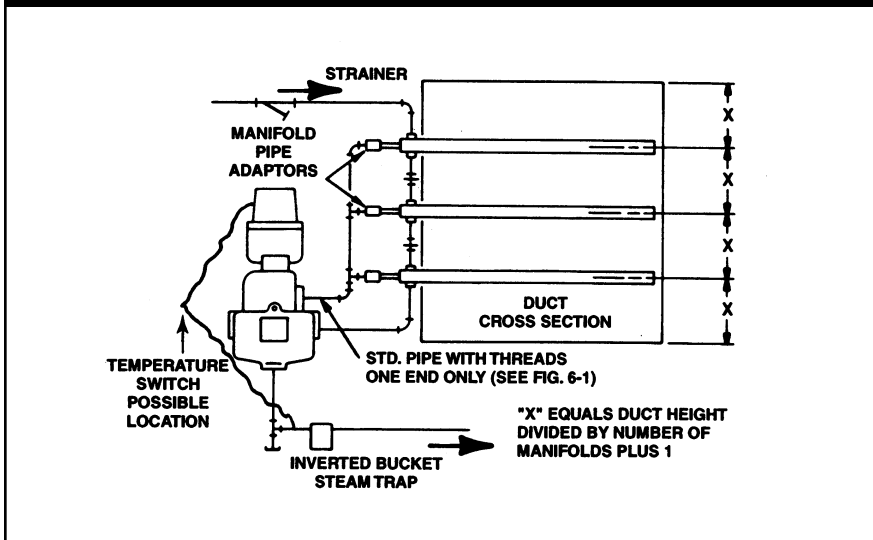

Figure 9-4. Piping of Same Size Manifold When All Manifolds Are Above Humidifier Inlet



When same size manifolds (as the separator) are used, the piping can eliminate the drain trap from the manifold jacket. Note that steam now discharges into an elbow, not a cross, and that the manifold steam jackets are not trapped separately.

Note: The humidifier steam inlet is below the bottom manifold. If the bottom manifold is below the humidifier inlet, piping should be as in Figure 9-3.

Note: When steam supply pressure is less than 10 psig and total length of manifolds is greater than 20 feet, trap manifolds separately as shown in Figure 9-3.

Pneumatic Piping for Air Operated Humidifier—AM Models

STEP 9A: Install Pneumatic Piping in accordance with Fig. 10-1 or engineer's layout.

- a. Control Air Supply. Unless otherwise specified, air supply for Armstrong Humidifiers should be 20 psig maximum. This air must be clean and dry.
- b. Air Piping. 1/4" plastic tubing or equivalent is recommended for all air connections.

Note: When a pilot positioner is furnished, it should be hooked up as shown in Fig. 10-3.

STEP 10A: Install and Connect Humidity Controller as specified by engineer in accordance with manufacturer's instructions. If location is not specified it may be installed in

the area controlled or in either the return air or exhaust air ducts.

Auxiliary Controls

Hi-Limit Duct Humidity Controller. A high limit humidistat is recommended in the duct at least 10 feet downstream from the humidifier to override the controlling humidistat. This high-limit humidistat automatically prevents local saturation at the point of steam introduction. It also prevents overloading the duct with vapor in the event of failure of air conditioning system components, incorrect control settings or tampering. See Fig. 10-1.

Interlocks for Shutdowns.

Humidifiers should be interlocked with fans for shutdown on power failure or other system trouble. Interlock should

be such that the valve will go to the closed position on a system shutdown rather than be locked in its position at time of shutdown. See Figure 10-2.

Temperature Switch for Automatic Warm Up. For systems that may be started and stopped, such as in laboratories or in operations which shut down each weekend, a temperature switch is recommended on the condensate outlet from the humidifier. Your Armstrong Representative can supply an immersion type unit that will automatically keep valves closed during warm up period after shutdown. This will avoid the discharge of condensate that can occur if steam is admitted to cold humidifier piping when the humidifier valve is open. See Fig. 10-1.

Figure 10-1. Standard compressed air hook-up for all pneumatically operated humidifiers. Pneumatic temperature switch shown.

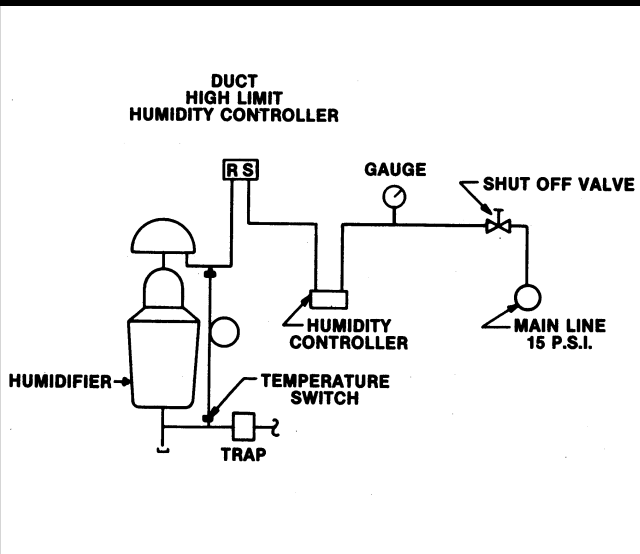

Figure 10-2. Compressed air hook-up for air operated humidifiers incorporating safety interlock for shutdown in the event of power failure to fan and an electric temperature switch to prevent water discharge on start-up when humidifier piping is cold.

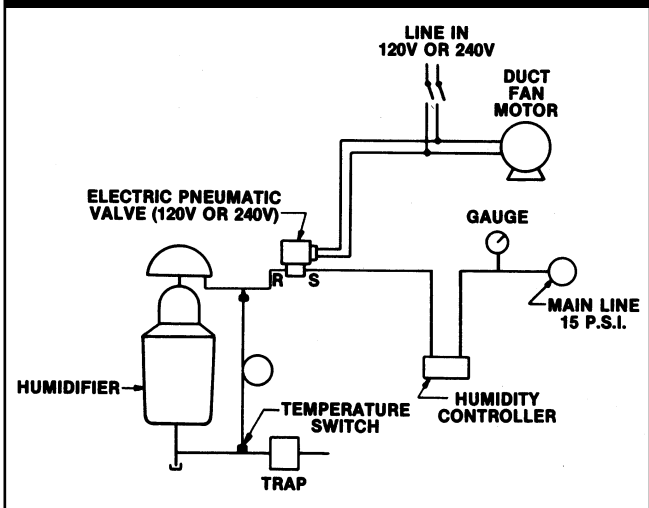

Figure 10-3. Compressed air hook-up for humidifiers utilizing a Honeywell MP953-F pneumatic operator with pilot positioner.

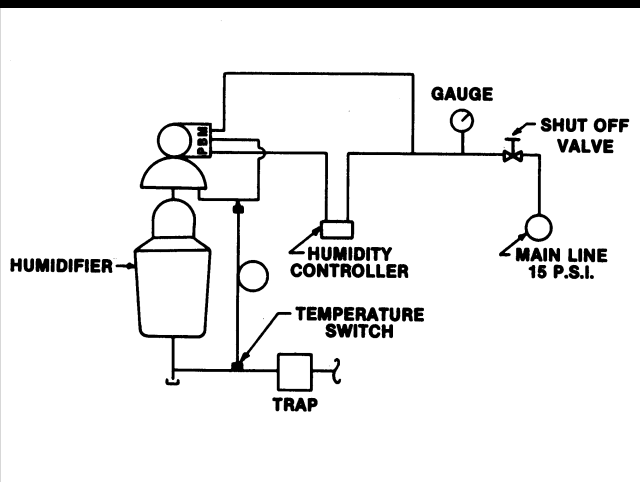
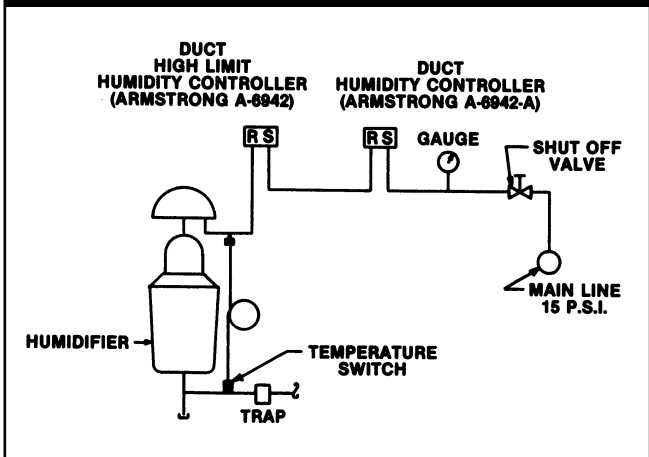

Figure 10-4. Compressed air hook-up for humidifiers utilizing two Armstrong Duct Humidity Controllers, one as the humidity controller, the other as a high limit controller.



Wiring for Electrically Operated Humidifiers—EM Models

EM Models

STEP 9E (EM): Make Electrical Connections as recommended by the manufacturers of the operators and controls.

“EM” Series electric motor operated humidifiers are furnished with a choice of Honeywell M9182A operators, Barber-Coleman MP361 or MP461, or Belimo AF24SR or NVF24 electric motorized operators. These operators may be controlled by compatible humidity controllers or electronic humidity panels.

For all EM operators, mount operator so that the motor shaft is horizontal to the floor.

STEP 10E (EM): Install Temperature Switch. Remove cover of switch for access to adjustable mounting strap. Strap the switch to the humidifier drain line piping just ahead of the steam trap.

Solenoid Models (DSA Models)

STEP 9E: Make Electrical Connections as diagrammed in Fig. 11-2. Be sure wiring is adequate for the requirements of the system. Check voltage ratings on operator nameplate.

STEP 10E: Install and Wire Humidity Controller as specified by the design engineer and in accordance with manufacturer’s instructions. If location is not specified, the controller may be installed in area controlled or in either the return air or exhaust air ducts.

STEP 11E: Install Temperature Switch. Remove cover of switch for access to adjustable mounting strap. Strap the switch to the humidifier drain line just ahead of the steam trap.

STEP 12E: Check Out Solenoid Valve. After making electrical connections, move the humidity setting indicator of the humidistat back and forth past the point corresponding with the actual room humidity. You should be able to hear the solenoid valve click open and click shut. For test purposes a jumper will have to be used on the temperature switch connections since the function of this switch is to prevent energizing the solenoid until the humidifier reaches steam temperature.

Auxiliary Controls for All Models

Hi-Limit Duct Humidity Controller. An enclosed switch type high limit humidistat is recommended in the duct at least 10 feet downstream from the humidifier to override the controlling humidistat. It is particularly recommended with on/off models. This high limit humidistat automatically prevents local saturation at the point of steam introduction. It also prevents overloading the duct with vapor in the event of failure of air conditioning system components, incorrect control settings or tampering.

Interlocks for Shutdowns. Humidifiers should be interlocked with fans for shutdown on power failure or other system trouble. Interlock should be such that valve will go to the closed position on a system shutdown rather than be locked in its position at time of shutdown.

Temperature Switch for Automatic Warm Up. This is a strap-on type and is connected to the interlock system to automatically keep valves closed during warm up period after shutdown. This will avoid the discharge of condensate that can occur if steam is admitted to cold humidifier piping when the humidifier valve is open.

Figure 11-1. Wiring diagram for HEM Series humidifiers using Honeywell M9182A operator and H915A potentiometer controller.

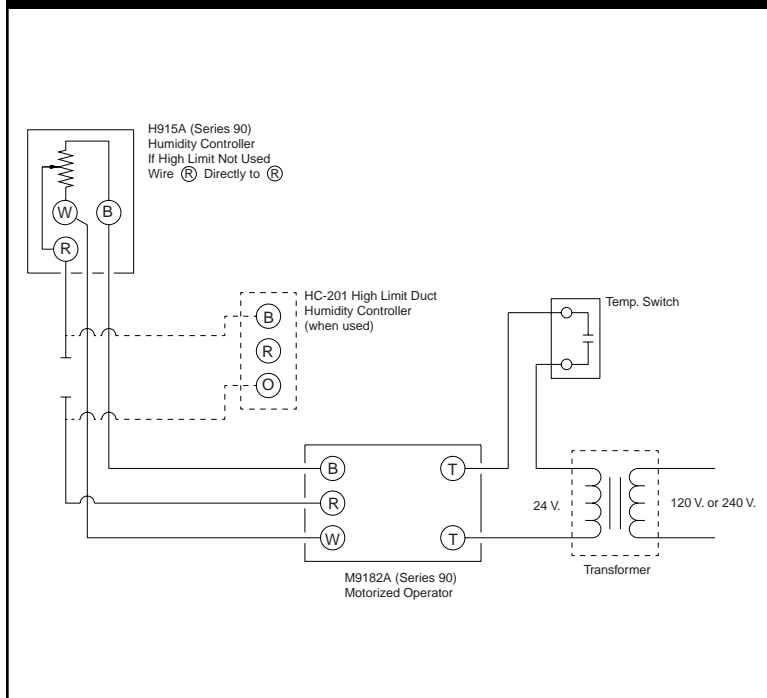
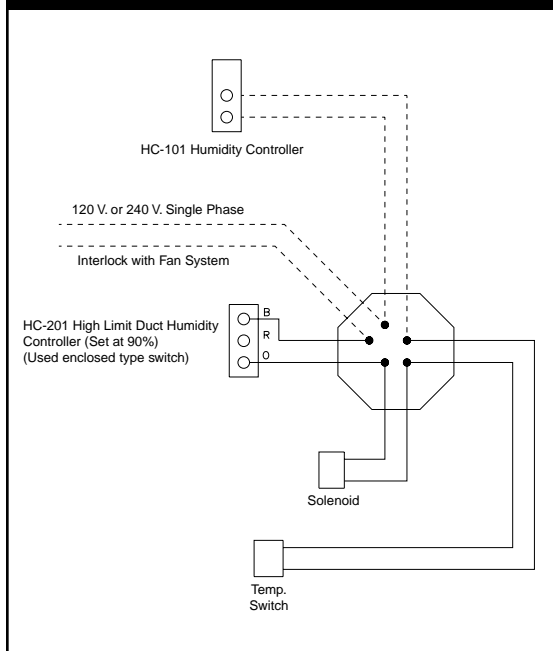

Figure 11-2. Wiring diagram for 120v or 240v Solenoid model humidifier. Wiring for auxiliary high limit duct humidity controller and interlock for system shutdown is shown in dotted lines.



NOTE: For wiring data covering Barber-Coleman operators, contact the factory or your Barber-Coleman dealer.

Figure 12-1. Wiring diagram for BLEM or BNVEM Series Humidifiers Using Armstrong 0-10 VDC Humidistats

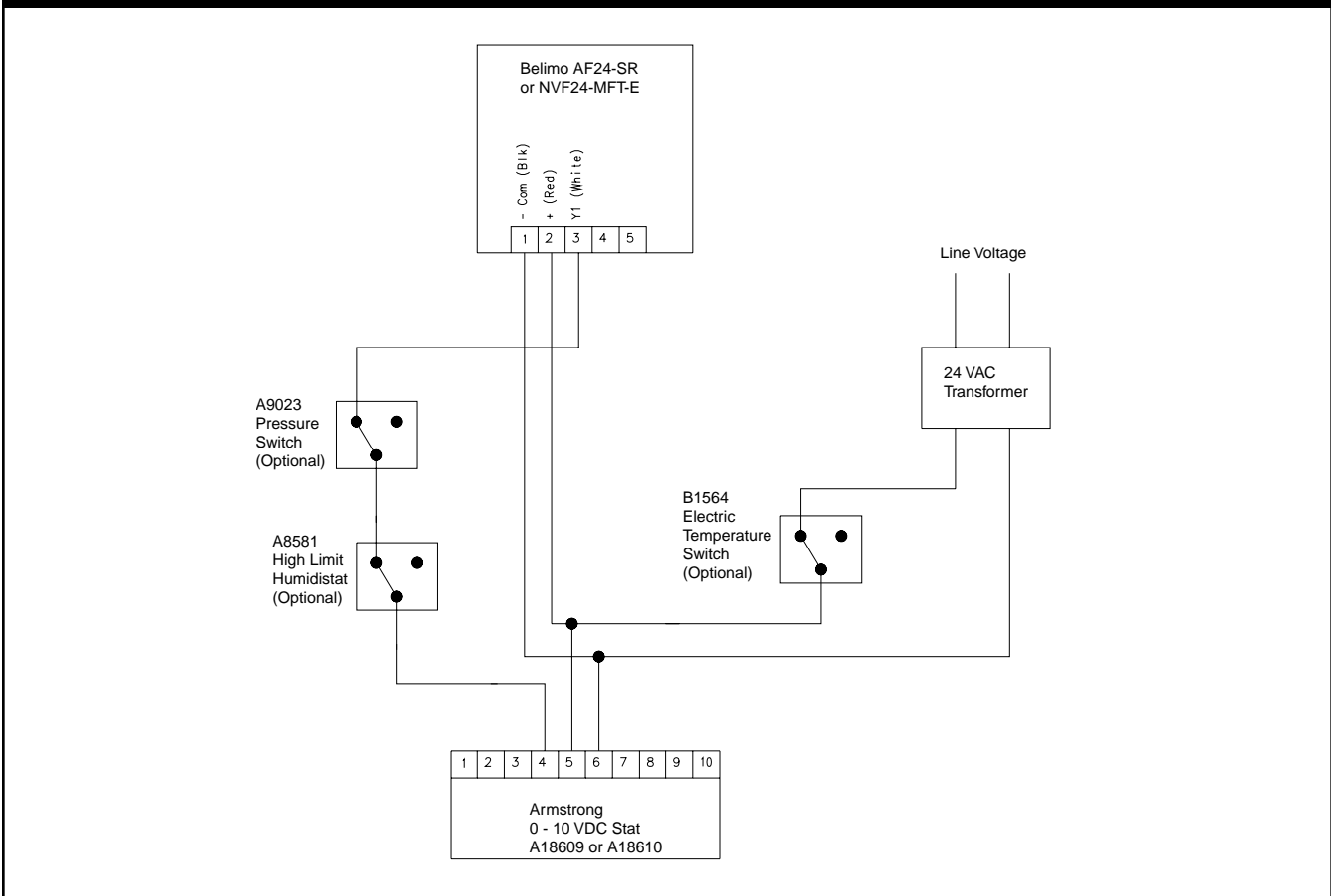
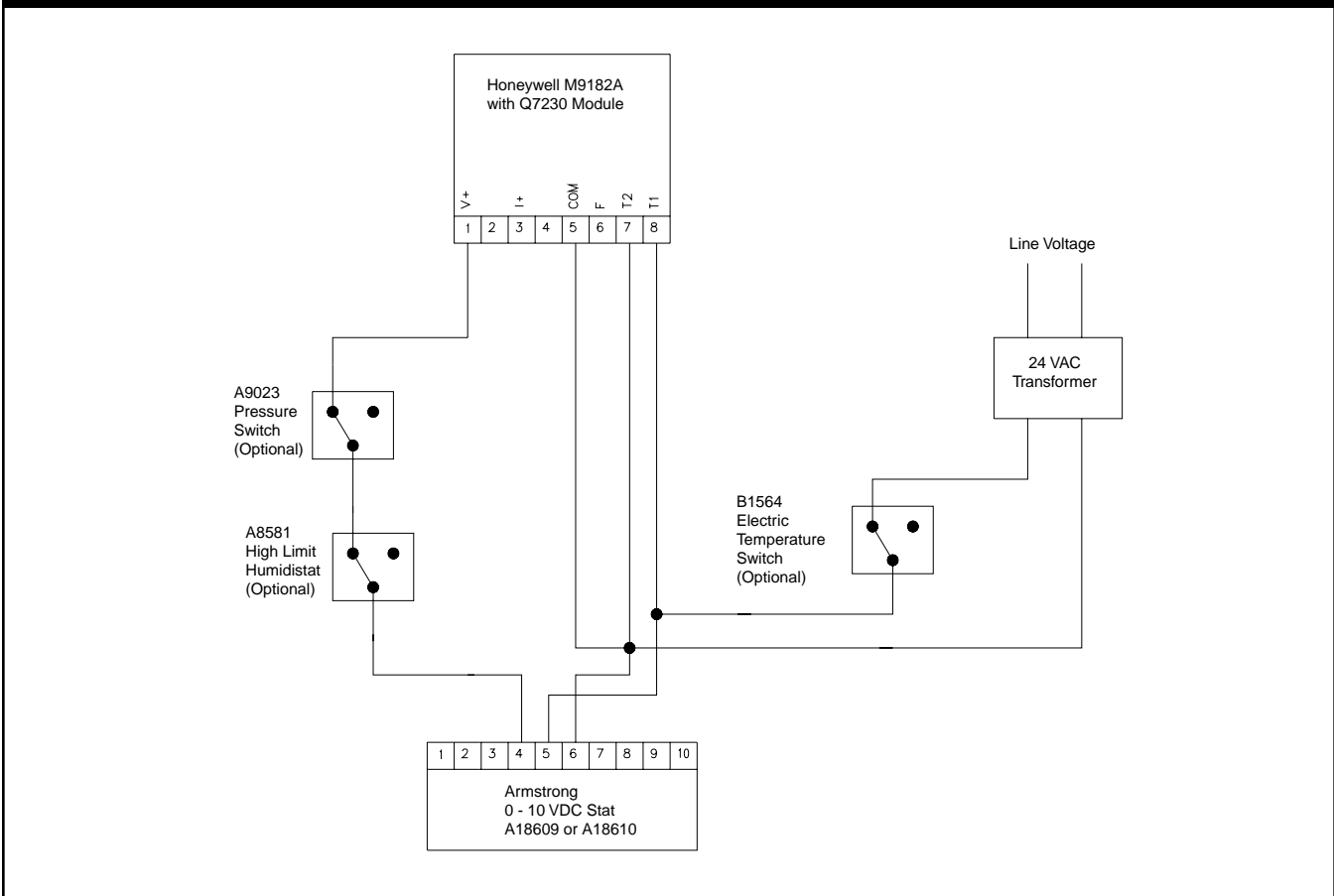

Figure 12-2. Wiring diagram for HEM Series Humidifiers Using Armstrong 0-10 VDC Humidistat



How Duct Type Humidifiers Work

After passing through the Armstrong inline strainer, steam supply enters the steam jacket of the manifold and circulates around the distribution pipe. Steam now enters the cast iron steam separating chamber. The use of cast iron as a separator is probably the single most important feature in the Armstrong humidifier design.

The preferred material of strength and durability, cast iron gives Series 9000 humidifiers flexibility in design without fabrication. In addition, castings mean better heat retention because of thicker walls. Which in turn means a lower rate of condensation.

Entering the main separating chamber, steam encounters a cupped baffle which reverses its flow and turns it back on itself. The outer walls of the casting form another cup, and the same thing happens again. These two 180° turns help condition the steam, reducing its volume and separating the condensate from the vapor.

Condensate from supply and radiation and most of the particulates in the steam not removed by the strainer collect in the large drain leg and are discharged through the inverted bucket drain trap.

Steam from the separating chamber flows around and through the valve which is actuated by a demand signal from the humidistat.

Next the steam flows into the drying chamber which is jacketed by the separating chamber. The drying chamber is filled with a stainless steel silencing material which almost completely absorbs the noise of escaping steam

How air-operated units work.

Air-operated units operate in the same manner as electric units except that they utilize a pneumatic humidistat as humidity controller in the space and an air operator to open and close the steam valve.

Explosion hazard humidification.

Sizing air-operated humidifiers for areas where an explosion hazard exists is done exactly as for other requirements except that they should be sized for the most severe conditions of makeup air, RH required and minimum steam pressure.

Figure 13-1. How Armstrong Conditioned Steam Humidifiers operate for air handling humidification

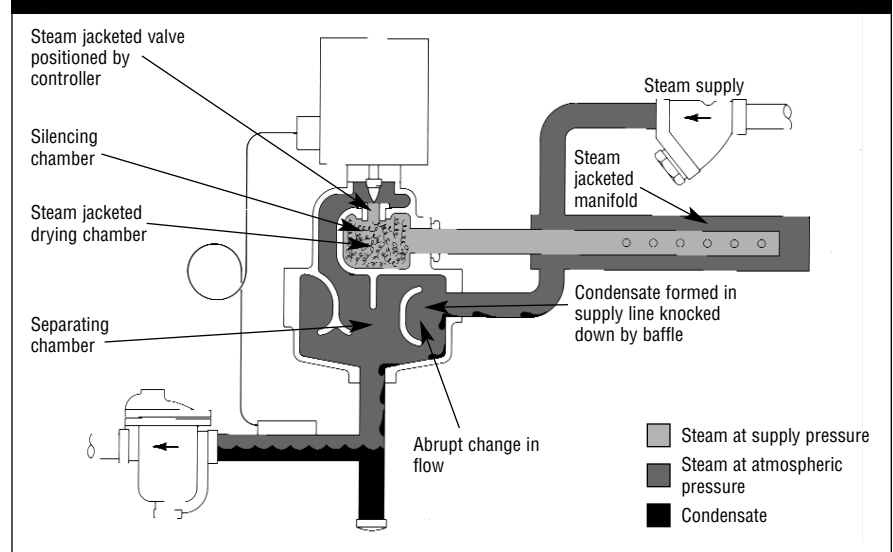

Putting the Humidifier Into Operation

When Temperature Switch Is Employed simply set humidity controller at desired level, and turn on the steam.

When Temperature Switch Is Not Employed deactivate operator control so that humidifier control valve will remain closed. Then:

- A. Open steam supply valve to bring humidifier up to temperature.
- B. When drain line from humidifier is at steam temperature, activate the operator control.
- C. Set desired relative humidity.

After the Humidifier Is In Operation

Clean Strainer. The screen in the strainer installed in the steam supply line should be cleaned a few days after the humidifier is placed in operation, and thereafter at least once each season—more often if you find much dirt in the screen.

Check Trap. The steam trap used to drain the humidifier should be inspected at the same time the strainer is cleaned.

Trouble Shooting

Humidifier Will Not Discharge Steam

- A. Control System at Fault.
 1. Faulty control valve operator.
 2. Faulty humidity controller.
 3. Faulty connections between humidity controller and control valve operator.
- B. Steam System Malfunction.
 1. Silencing chamber plugged with

dirt. Remove and replace silencing material and retainer.

2. Strainer screen plugged.
3. Dirt in steam line.
4. Steam valve closed in line to humidifier.
5. Pressure reducing valve out of order.

Humidifier Discharges Water

- A. Faulty Steam Supply.
 1. Long, untrapped supply line.
 2. Humidifier supply from bottom or side of steam header.
 3. Untrapped valve in vertical, down feed supply line.
 4. Boiler carryover.
- B. Faulty Drainage.
 1. Steam trap filled with dirt.
 2. Return line pressure above humidifier pressure.
 3. Too much vertical lift.
 4. Wrong type of drain trap used. Always use the Armstrong Inverted Bucket Steam Trap.
- C. Faulty Operation.
 1. Faulty temperature switch.
 2. Humidity controller set up before humidifier has reached steam temperature.

Humidifier Discharges Continuously even though humidity has reached desired level.

- A. Humidity controller out of calibration.
- B. Trouble in Humidifier
 1. Valve stem "frozen" to stem seal due to unusual chemical or corrosive conditions in steam system.
 2. Operator spring broken.
 3. Dirt or scale between valve and seat.

Humidifier Dimensions (Continued from page 2)

Model	A	B	C	D	E	F	G
91	5/8"	3/8"-16	1 1/32"	7/16" Dia. Thru Hole	2"	3 7/16"	—
92	5/8"	UNC .56	1 1/32"		2 1/2"	3 7/16"	—
93	5/8"	Deep	1/2"		2 3/4"	3 15/16"	—
94	—	—	—		3 7/8"	6 9/16"	3 11/16"

*94 size has four holes as shown in Figure 14-1.

Steam humidifiers (or other products) should be installed in locations that allow routine inspection and accessibility for maintenance operations. Armstrong recommends that steam humidifiers not be placed in locations where unusual instances of malfunction of the humidifiers or the systems might cause damage to non-repairable, irreplaceable, or priceless property.

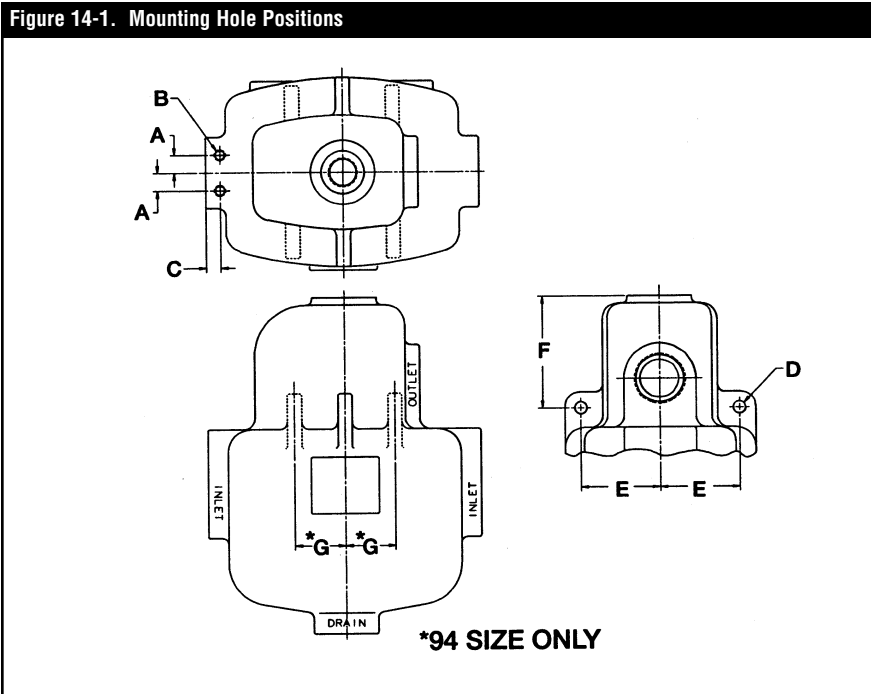

Steam Pipe Capacities

For computing ability of piping to deliver an adequate supply of steam to humidifier. Capacities shown are in pounds per hour.

Pipe Size In.	Pressure drop, psi per 100 ft. of pipe length				
	1/8	1/4	1/2	3/4	1
1	24	31	44	54	62
1 1/4	52	68	97	120	140
1 1/2	81	100	150	180	210
2	160	210	300	370	430
2 1/2	270	350	500	610	710

Pipe Size In.	Pressure drop, psi per 100 ft. of pipe length					
	1/8	1/4	1/2	3/4	1	2
1	27	38	53	65	76	110
1 1/4	59	83	120	140	160	230
1 1/2	91	130	180	220	260	360
2	180	260	370	450	520	740
2 1/2	300	430	600	740	860	1210

Pipe Size In.	Pressure drop, psi per 100 ft. of pipe length					
	1/8	1/4	1/2	3/4	1	2
3/4	15	21	30	37	43	60
1	30	43	61	75	86	122
1 1/4	67	95	130	160	190	260
1 1/2	100	140	210	250	290	410
2	210	300	420	510	590	840
2 1/2	340	490	690	850	980	1380

Pipe Size In.	Pressure drop, psi per 100 ft. of pipe length					
	1/4	1/2	3/4	1	2	5
3/4	27	38	47	54	76	120
1	54	77	94	110	150	240
1 1/4	120	170	210	240	340	530
1 1/2	180	260	320	370	520	830
2	370	530	650	750	1060	1680
2 1/2	620	870	1070	1240	1750	2760

SteamStik Aluminum Manifolds

Preliminary Procedure

STEP 1: Check Shipment Against Packing List. All components are listed on the packing slip. Report any shortages **immediately**. If the humidifier or accessories have been damaged in transit, notify us and file claim with the transportation company.

If your order covers more than one unit, separate each complete unit. Humidifier tagging and manifold tagging will be the same as shown on the packing list. Model, Serial Number, Steam Pressure, Orifice and Orifice

Restriction (if any) are on the metal plate on the humidifier body. Operator for electric motor operated unit is shipped separately but marked with the serial number of the humidifier with which it must be used. Be sure serial numbers agree.

STEP 2: Spot Humidifier Locations. Locate each humidifier according to the engineer's layout or as indicated by your Armstrong Representative. If you must locate the humidifiers yourself, be sure to read and observe the "Do's and Don'ts" on the following page.

Manifold Installation

STEP 3: Cut Hole in Duct or Plenum for Manifold. Cut a 2" hole for each manifold location.

STEP 4: Insert Manifold in Duct. Outlet holes must point upstream into air flow with **all** SteamStik manifolds. Where manifold is positioned horizontally, use a spirit level. Manifolds longer than one foot should be supported. When supporting the manifold on the far end allow for manifold expansion and contraction of 1/2" - 1".

Continue installation with step 5 beginning on page 8.

Figure 15-1. Model 90 Single Manifold Installation

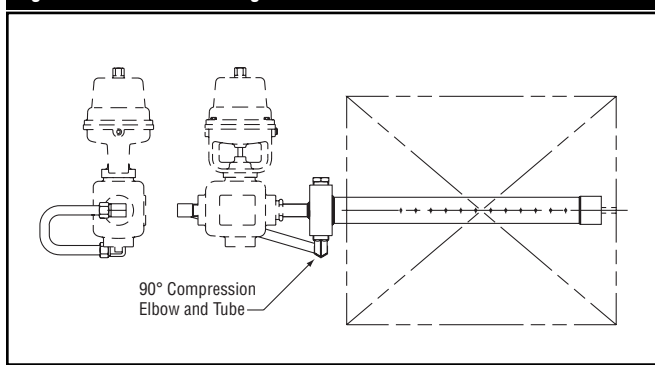
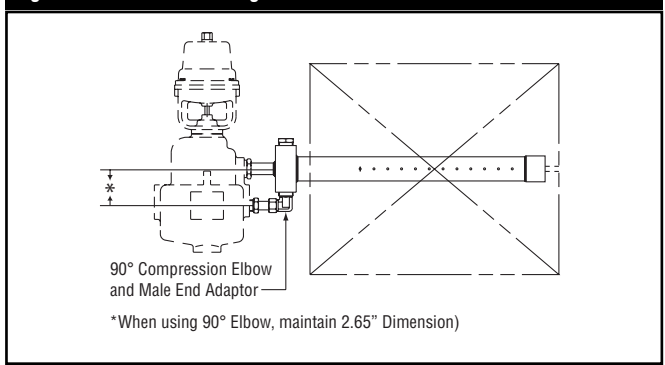

Figure 15-2. Model 91 Single Manifold Installation



Note: Maximum operating pressure is 15 psig. Steam system should have a neutral Ph of 7.2 to 7.6.

Table 15-1. Fittings and Adaptors

Single Manifold Installation (reducer bushings A17891 included)			
Description	Part No.	Manifold Outlet Fittings	Number of reducer bushing(s) supplied
Model 90 Horizontal	B4583	Elbow/Tube Fitting with 1/2" MNPT Connection	1 (inlet)
Model 90 Vertical	B4584		
Model 91	B3931		
Single Manifold Installation (reducer bushings A17891 included)			
Description	Part No.	Manifold Outlet Fittings	Number of reducer bushing(s) supplied
All 90/91 Installations	A4967B	Not Applicable	2 (1 inlet, 1 outlet)

Multiple manifold applications will be supplied with (1) A4967B adapter each. Vertical mounted manifolds will be supplied with an A4967B adapter.

Figure 15-3. Multiple Manifold Installation

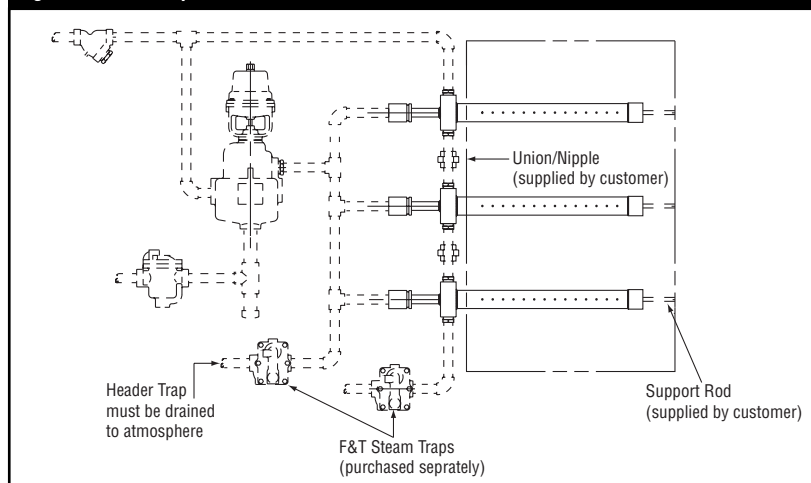

Table 15-2. Header size of manifold piping out of humidifier

Separator Size	Minimum Pipe Size	Suggested Header Size
90	1/2"	3/4"
91	1/2"	2"
92	3/4"	2-1/2"
93	1"	3"
94	2"	5"

Additional Assistance

For more information, contact your local Armstrong Representative. Your local Representative will be able to supply you with the following:

- Humid-A-ware™ Software — For detailed information on customizing humidification schedules and calculating non-wetting distances and humidification loads, refer to Armstrong's Humid-A-ware humidification sizing and selection software. It can be downloaded from Armstrong's web site at www.armstrong-intl.com.
- Humidification Solution Source Bulletin 596 — Provides information on different types of humidification methods along with detailed description of Armstrong's complete line of humidification products.
- Video Tapes - It's The Humidity — Part one is a video documentary covering the essentials of humidity and outlining the primary reasons for humidity control. What is humidity? Relative humidity? What is dew point? Enthalpy? How does evaporation affect comfort? How does humidity conserve energy? All of these questions in practical and entertaining demonstrations.

Part two is a look at the four basic methods of large-scale humidification. Through animation, the tape discusses the operation of evaporative pan, wetted element, water spray and steam humidifiers, and rates their ability to meet efficiency, maintenance, controllability, sanitation and cost requirements.
- Application Guidelines — Discusses specific humidity control problems and applications in a detailed problem/solution format.
- Installation and Maintenance — IB-52—Repair and adjustment for Honeywell MP 953-B, F. Also gives bonnet seal replacement and stem adjustment.
- Installation and Maintenance — IB-53—Repair and adjustment for Armstrong C-1801 Pneumatic operator. Also gives start point adjustment, and valve and seat repair.
- Installation and Maintenance — IB-61 — Armstrong A-5503 Pneumatic Temperature Switch application, operation and installation.
- Installation and Maintenance — IB-62 — Troubleshooting Guide for solenoid operated steam humidifiers. Tells what to check for when valve will not open, close or the coil burns out.
- Installation and Operation — Bulletin 549 — Humidifiers for Direct Area Humidification.

Limited Warranty and Remedy

Armstrong International, Inc. ("Armstrong") warrants to the original user of those products supplied by it and used in the service and in the manner for which they are intended, that such products shall be free from defects in material and workmanship for a period of one (1) year from the date of installation, but not longer than 15 months from the date of shipment from the factory, [unless a Special Warranty Period applies, as listed below]. This warranty does not extend to any product that has been subject to misuse, neglect or alteration after shipment from the Armstrong factory. Except as may be expressly provided in a written agreement between Armstrong and the user, which is signed by both parties, Armstrong **DOES NOT MAKE ANY OTHER REPRESENTATIONS OR WARRANTIES, EXPRESS OR IMPLIED, INCLUDING, BUT NOT LIMITED TO, ANY IMPLIED WARRANTY OF MERCHANTABILITY OR ANY IMPLIED WARRANTY OF FITNESS FOR A PARTICULAR PURPOSE.**

The sole and exclusive remedy with respect to the above limited warranty or with respect to any other claim relating to the products or to defects or any condition or use of the products supplied by Armstrong, however caused, and whether such claim is based upon warranty, contract, negligence, strict liability, or any other basis or theory, is limited to Armstrong's repair or replacement of the part or product, excluding any labor or any other cost to remove or install said part or product, or at Armstrong's option, to repayment of the purchase price. As a condition of enforcing any rights or remedies relating to Armstrong products, notice of any warranty or other claim relating to the products must be given in writing to Armstrong: (i) within 30 days of last day of the applicable warranty period, or (ii) within 30 days of the date of the manifestation of the condition or occurrence giving rise to the claim, whichever is earlier. **IN NO EVENT SHALL ARMSTRONG BE LIABLE FOR SPECIAL, DIRECT, INDIRECT, INCIDENTAL OR CONSEQUENTIAL DAMAGES, INCLUDING, BUT NOT LIMITED TO, LOSS OF USE OR PROFITS OR INTERRUPTION OF BUSINESS.** The Limited Warranty and Remedy terms herein apply notwithstanding any contrary terms in any purchase order or form submitted or issued by any user, purchaser, or third party and all such contrary terms shall be deemed rejected by Armstrong.

Special Warranty Periods are as follows:

Series EHU-700 Electric Steam Humidifier, Series HC-4000 HumidiClean Humidifier and GFH Gas Fired Humidifier with Ionic Beds:

Two (2) years after installation, but not longer than 27 months after shipment from Armstrong's factory.



Armstrong Humidification Group

816 Maple Street, Three Rivers, Michigan 49093 – USA Phone: (269) 273-1415 Fax: (269) 273-9500