

# Tendeur à lanterne 2 anneaux, acier

**18-41****MATIÈRE**

- Anneau en acier zingué blanc Fe 430 B, et cage en acier zingué blanc C15.
- Marquages : diamètre, CE.
- Attention : ne pas utiliser comme élément de traction ou de levage.
- Dimensions susceptibles de varier, pour toutes dimensions précises, nous consulter.

**PRODUITS ASSOCIÉS**

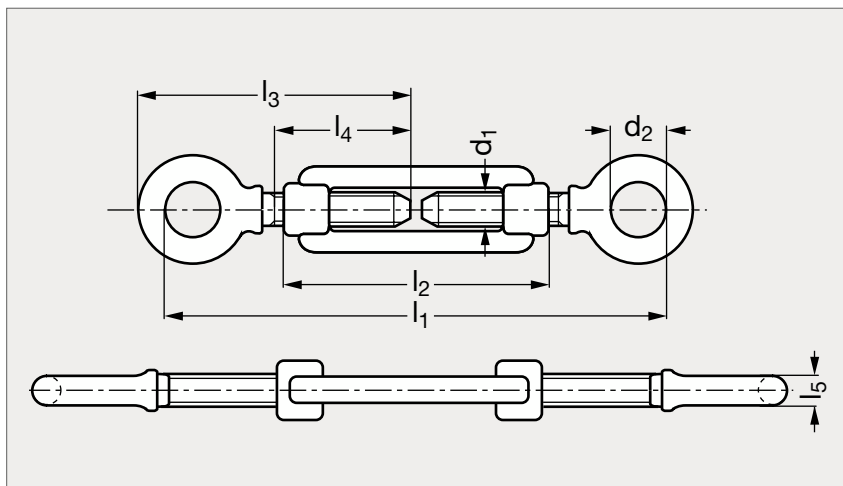

Plaque d'identification  
18-98  
Page 1107



Tendeur 2 crochets acier  
18-43  
Page 1173



Tendeur anneau et crochet  
acier 18-45  
Page 1175



Tendeur 2 chapes acier  
18-47  
Page 1177

	d <sub>1</sub>	d <sub>2</sub>	l <sub>1</sub> min.	l <sub>1</sub> max.	l <sub>2</sub>	l <sub>3</sub>	l <sub>4</sub>	l <sub>5</sub>
18-411-5	M 5	8	119	180	80	61	45	3,5
18-411-6	M 6	10	148	207	80	74,5	55	4,5
18-411-8	M 8	11	155	235	105	79	57	6
18-411-10	M10	14	190	280	125	94	68	7
18-411-12	M12	17	215	310	140	106	74	8
18-411-14	M14	18	250	380	170	127	93	8,5
18-411-16	M16	25	290	430	190	145	100	13

	d <sub>1</sub>	d <sub>2</sub>	l <sub>1</sub> min.	l <sub>1</sub> max.	l <sub>2</sub>	l <sub>3</sub>	l <sub>4</sub>	l <sub>5</sub>
18-411-18	M18	25	340	495	205	161	117	14
18-411-20	M20	26	370	535	220	185	130	16
18-411-22	M22	30	410	590	240	200	140	18
18-411-24	M24	34	450	645	260	220	145	18
18-411-27	M27	38	490	690	300	230	160	20
18-411-30	M30	41	530	720	310	250	170	25

Exemple  
de commande**Référence**  
**18-411-5**

composants.emile-maurin.fr

**EMILE MAURIN**  
ELEMENTS STANDARD MECANIQUE