

Mod. **VAPE/N**

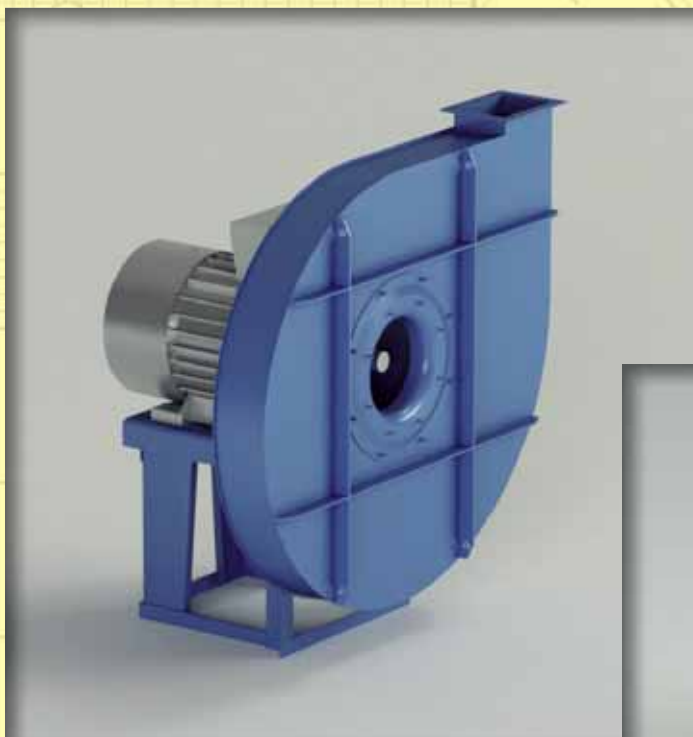

$Q = 140 \div 22000 \text{ m}^3/\text{h}$

$Q = 0.04 \div 6 \text{ m}^3/\text{s}$

$p_t = 100 \div 3000 \text{ mmH}_2\text{O}$

$p_t = 1000 \div 30000 \text{ Pa}$

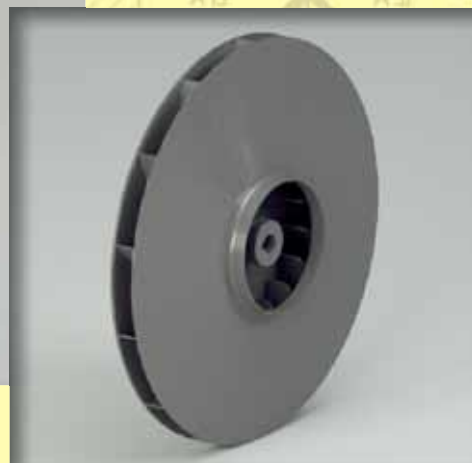

Campo di lavoro

Portate basse-medie. Pressioni alte.

Tipo di pala

Curva, rovescia (negativa), vedi pag. 2.2.

Applicazioni

Per trasporto pneumatico, polveri, essiccazione, pressurizzazione. Adatto per impieghi nel campo industriale delle fonderie, pastifici, forni, chimico.

Esecuzioni costruttive standard

Es.1-Es.4-Es.5-Es.8-Es.9-Es.12, vedi pag. 2.5 - 2.6.

Temperature del fluido standard

-10÷+60°C. Per altre temperature vedi da pag. 1.12 a pag. 1.15.

Tipo di costruzione

Ventilatore in lamiera di Fe360, girante in Fe360 equilibrata staticamente e dinamicamente. Per altri materiali vedi da pag. 1.12 a pag. 1.15.

Dati di funzionamento

Condizioni dell'aria all'aspirazione T=20°C, 0m.s.l.m. e ρ=1.205 kg/m³.

Rumorosità

 Espresa in potenza sonora L_{WA} [dB(A)] rilevata in campo libero con ventilatore canalizzato, vedi da pag. 1.43 a pag. 1.49.

Orientamenti

N°8 RD (rotazione oraria vista lato trasmissione) e N°8 LG. Ventilatore in versione imbullonata orientabile per le taglie 400-630, con supporto anteriore e quindi non orientabile dalla grandezza 710 a trasmissione, sempre orientabile nei ventilatori direttamente accoppiati senza supporto anteriore. Vedi pag. 2.7.

Costruzioni speciali

Vedi da pag. 2.20 a pag. 2.30.

Avviamento ventilatore

L'avviamento deve avvenire con ventilatore parzializzato, in funzione dell'assorbimento massimo del ventilatore.

Classi giranti

La seguente tabella fa riferimento a condizioni di lavoro standard. In condizioni di esercizio gravose si consiglia di contattare il servizio clienti di CORAL per conoscere la tipologia di girante più idonea.

GRANDEZZA VENTILATORE • Grandeur • Size • Größe • Tamaño	RPM MASSIMO • Maxi tours/min. • Max rpm • Max. U/min • R.p.m. máx.		
	CLASSE I	CLASSE II	CLASSE III
VAPE400	5000		
VAPE450/R	5000		
VAPE450	5000		
VAPE500	5000		
VAPE560/R	5000		
VAPE560	4700	5000	
VAPE630/R	4400	4850	
VAPE630	4100	4550	5000
VAPE710/R	3700	4100	4500
VAPE710	3550	3850	4250
VAPE800/R	3400	3700	4000
VAPE800	3250	3550	3850
VAPE900/R	3100	3400	3700
VAPE900	2950	3250	3550
VAPE1000/R	3100	3550	3850
VAPE1000	3300	3550	3900
VAPE1120/R	3200	3450	3700
VAPE1120	3000	3250	3500
VAPE1250	2650	2800	3000
VAPE1400	2350	2500	2650
VAPE1600	2000	2150	2300

VALORI VALIDI FINO A 60°C

 • Valeurs valables jusqu'à 60°C • Values valid up to 60°C
 • Werte bis 60°C gültig • Valores válidos hasta 60°C

FRA • entre • between • zwischen • entre	60°C	E • et • and • und • y	100°C	DECLASSARE VELOCITÀ • déclasser vitesse • degrade speed • Geschwindigkeit herabsetzen • rebajar velocidad	4%
			100°C		150°C
	150°C	200°C	16%		
	200°C	250°C	23%		
	250°C	300°C	30%		
	300°C	350°C	37%		
	350°C	400°C	45%		
	400°C	450°C	54%		
	450°C	500°C	64%		

■ **Domaine de travail**

Débits moyens-faibles. Hautes pressions.

Type d'ailette

Courbée, inversée (négative), voir page 2.2.

Applications

Pour transport pneumatique, poussières, séchage, pressurisation. Convient à l'emploi dans le domaine industriel des fonderies, fabriques de pâtes, fours, chimique.

Configurations de constructions standard

Ex.1 - Ex.4 - Ex.5 - Ex.8 - Ex.9 - Ex.12, voir pages 2.5 - 2.6.

Températures du fluide standard

-10÷+60°C. Pour d'autres températures voir pages 1.12-1.15.

Type de fabrication

Ventilateur en tôle de Fe360, turbine en Fe360 équilibrée statiquement et dynamiquement. Pour d'autres matériaux, voir pages 1.12-1.15.

Données de fonctionnement

Conditions de l'air à l'aspiration T=20°C, 0 m asl et ρ=1.205 kg/m³.

Niveau sonore

 Exprimé en puissance sonore L_{WA} [dB(A)], relevé à l'air libre avec un ventilateur canalisé, voir pages 1.43 - 1.49.

Orientations

8 RD (rotation dans le sens des aiguilles d'une montre côté transmission) et 8 LG. Ventilateur en version boulonnée orientable pour les tailles 400-630, avec un support avant et donc non orientable de la grandeur 710 à transmission, toujours orientable dans les ventilateurs directement accouplés sans support avant. Voir page 2.7.

Fabrications spéciales

Voir pages 2.20-2.30.

Mise en marche du ventilateur

Le démarrage doit se faire avec un ventilateur partialisé, en fonction de l'absorption maximale du ventilateur.

Classes de turbines

Le tableau ci-dessus fait référence aux conditions de travail normales, en conditions de travail pénibles, on préconise de contacter le service clientèle de CORAL pour connaître le type de turbine le plus adapté.

■ **Field of operation**

Medium-low flow rates. High pressures.

Blade type

Curve, backward (negative), see pg. 2.2.

Applications

For pneumatic transport, dust, drying, pressurization. Suitable for applications in industrial fields like foundries, pasta factories, bakeries, chemicals.

Standard constructional arrangements

Arr.1 - Arr.4 - Arr.5 - Arr.8 - Arr.9 - Arr.12, see pgs. 2.5 - 2.6.

Standard fluid temperatures

-10÷+60°C. For other temperatures see pgs. 1.12 to 1.15.

Type of construction

Fan in Fe360 plate, impeller in Fe360 statically and dynamically balanced. For other materials see pgs. 1.12 to 1.15.

Operating specifications

Condition of inlet air T=20°C, 0 m above sea level and ρ=1.205 kg/m³.

Noise level

 Expressed as sound power L_{WA} [dB(A)] measured in free field with ducted fan, see pgs. 1.43 to 1.49.

Orientations

No.8 RD (clockwise viewed from transmission side) and No.8 LG. Fan in bolted orientable version for sizes 400-630, with front support and so not orientable for sizes 710 and above with transmission drive, always orientable for directly coupled fans without front support. See pg. 2.7.

Special applications

See pgs. 2.20 to 2.30.

Fan start-up

During start-up the fan flow rate must be limited, calibrated for the fan's maximum electrical input.

Impeller classes

The above table refers to standard operating conditions, in heavy-duty service conditions it is advisable to contact the CORAL Customer Service to establish the most suitable type of impeller.

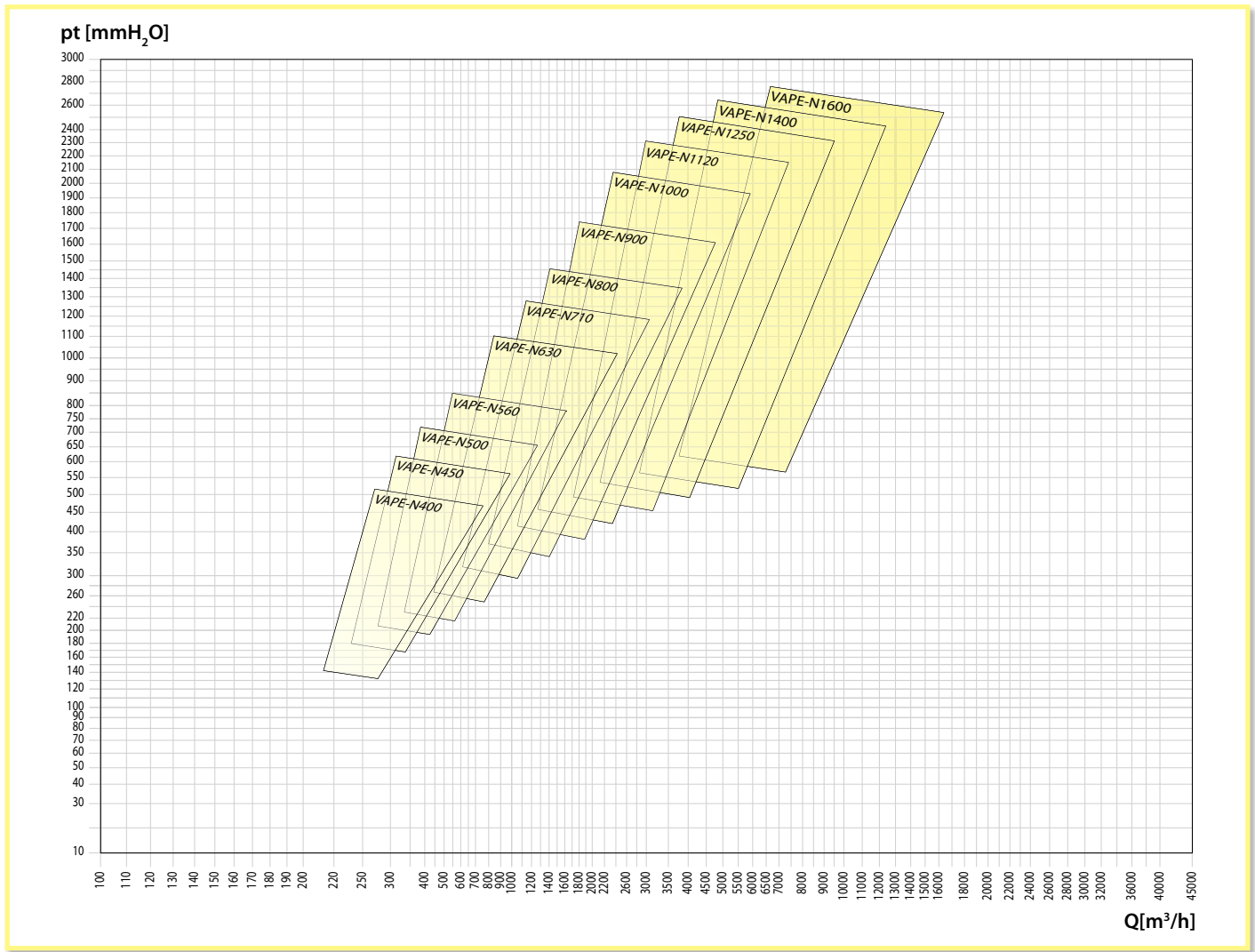

Arbeitsbereich

Niedrige - mittlere Fördermengen. Hohe Drücke.

Schaufelform

Kurve, rückwärts gekrümmt (negativ), siehe Seite 2.2.

Anwendungen

Zum Transport von Stäuben, zur Trocknung und für mit Überdruck zu beaufschlagende Räume. Zur Verwendung im industriellen Bereich, Giessereien, Nudelfabriken, Öfen und der Chemie geeignet.

Konstruktive Standardausführungen

Ausf. 1-Ausf. 4-Ausf. 5-Ausf. 8-Ausf. 9-Ausf. 12, siehe Seiten 2.5 - 2.6.

Standardtemperatur des Mediums

-10 ÷ +60°C. Für andere Temperaturen siehe Seiten 1.12 bis 1.15.

Konstruktionsart

Ventilator aus Blech Fe360, Laufrad aus Fe360, statisch und dynamisch ausgewuchtet. Für andere Materialien siehe Seiten 1.12 bis 1.15.

Betriebsdaten

Physikalischer Zustand der Ansaugluft T = 20°C, 0 m ü. M. und ρ = 1.205 kg/m³.

Geräuschpegel

Angegeben als Schalleistungspegel L_{w,A} [dB(A)] mit Messung im Freifeld und an Rohren angeschlossenem Ventilatore, siehe Seiten 1.43 bis 1.49.

Ausrichtung

8 Modelle RD (Drehrichtung im Uhrzeigersinn, von Antriebsseite aus gesehen) und 8 Modelle LG. Angeschraubter, in der Ausrichtung veränderbarer Ventilator in den Größen 400-630, mit Vorderstütze und damit nicht veränderbar ab Größe 710 mit Riementrieb, immer ausrichtbar bei allen direkt angetriebenen Ventilatoren ohne Vorderstütze, siehe Seite 2.7.

Spezialausführungen

Siehe Seiten 2.20 bis 2.30.

Ventilator-Anlauf

Der Ventilatoranlauf muss bei teilweise geschlossenem Ventilator erfolgen, in Abhängigkeit von der maximalen Stromaufnahme des Motors.

Laufradklassen

Die obestehende Tabelle bezieht sich auf normale Betriebsbedingungen. Bei erschwerenden Betriebsbedingungen wird empfohlen, den Kundenservice von CORAL zu kontaktieren, um den am besten geeigneten Laufradtyp zu bestimmen.

Campo de trabajo

Caudales bajo-medios. Presiones altas.

Tipo de pala

Curva, invertida (negativa), ver pág. 2.2.

Aplicaciones

Para transporte neumático, polvos, desecación y presurización. Apto para el uso en el campo industrial: fundiciones, fábricas de pasta, hornos e industria química.

Variantes constructivas estándares

Ejec.1-Ejec.4-Ejec.5-Ejec.8-Ejec.9-Ejec.12, ver págs. 2.5 - 2.6.

Temperaturas del fluido estándares

De -10 a +60°C. Para otras temperaturas, ver págs. de 1.12 a 1.15.

Tipo de construcción

Ventilador de chapa en Fe360, rotor en Fe360 equilibrado estática y dinámicamente. Para otros materiales, ver págs. de 1.12 a 1.15.

Datos de funcionamiento

Condiciones del aire en aspiración T=20°C, 0 m SNM y ρ=1.205 kg/m³.

Niveles de ruido

Expresados en potencia sonora L_{w,A} [dB(A)] medida en campo abierto con ventilador canalizado, ver págs. de 1.43 a 1.49.

Orientaciones

8 RD (rotación dextrógira vista desde el lado de transmisión) y 8 LG. Ventilador en versión emperrada orientable para tamaños 400-630, con soporte delantero, por lo cual no es orientable a partir del tamaño 710 de transmisión, siempre orientable en ventiladores acoplados directamente sin soporte delantero. Ver pág. 2.7.

Construcciones especiales

Ver págs. de 2.20 a 2.30.

Puesta en marcha del ventilador

La puesta en marcha debe efectuarse con ventilador parcializado, en función de la absorción máxima del ventilador.

Clases de rotores

La tabla arriba hace referencia a condiciones de trabajo estándares, en condiciones de funcionamiento pesadas, se aconseja llamar al Servicio de atención al cliente de CORAL para conocer el tipo de rotor más adecuado.

VAPE/N

Tipo • Type • Type • Typ • Tipo		P inst. [kW]	n	LpA [dB(A)]	Tolleranza sulla portata ±5% • Tolérance sur le débit ±5% • Load tolerance ±5% • Durchsatztoleranz ±5% • Tolerancia respecto caudal ±5%														
Ventilatore • Ventilateur • Fan • Ventilator • Ventilador	Motore • Moteur • Motor • Motor • Motor				Q [m³/h]														
					285	360	400	430	470	540	650	720	790	865	935	1080	1225		
					pt[mmH ₂ O]														
VAPE400/N2	71	0,55	2845	56	300	308	310	310	308										
VAPE400/N2	80	0,75	2845	57	300	308	310	310	308	305	294								
VAPE450/N2	80	1,1	2845	58	374	380	385	388	390	393	393	389							
VAPE450/N2	90	1,5	2860	58	376	383	387	390	391	394	395	392	390	383					
VAPE500/N2R	90	1,5	2860	59	420	426	430	432	434	438	442	443	441	439	435				
VAPE500/N2	90	2,2	2920	60	474	484	487	489	491	498	502	506	509	509	504	500			
VAPE560/N2R	90	2,2	2920	61				543	547	552	560	563	566	568	570				
VAPE560/N2R	100	3	2920	62				543	547	552	560	563	566	568	570	569	567		
VAPE560/N2	100	3	2920	63				600	602	609	617	622	626	629	633	638	638		
VAPE560/N2	112	4	2950	64				610	612	619	627	632	636	639	643	648	650		
VAPE630/N2R	112	4	2950	64						682	690	693	701	704	708	716	719		
VAPE630/N2R	132	5,5	2950	65						682	690	693	701	704	708	716	719		
VAPE630/N2	132	5,5	2950	66								785	792	800	803	806	810		
VAPE630/N2	132	7,5	2950	68								785	792	800	803	806	810		
VAPE710/N2R	132	7,5	2950	70								874	879	883	889	897	906		
VAPE710/N2R	160	11	2960	71								878	883	887	893	901	910		
VAPE710/N2	160	11	2960	73											986	990	994		
VAPE710/N2	160	15	2960	73											986	990	994		
VAPE800/N2R	160	15	2960	75															
VAPE800/N2R	160	18,5	2960	75															
VAPE800/N2	160	18,5	2960	76															
VAPE800/N2	180	22	2960	76															
VAPE900/N2R	180	22	2960	78															
VAPE900/N2R	200	30	2960	78															
VAPE900/N2	200	30	2960	79															
VAPE900/N2	200	37	2960	79															
VAPE1000/N2R	225	45	2960	80															
VAPE1000/N2R	250	55	2960	80															
VAPE1000/N2	250	55	2960	81															
VAPE1000/N2	280	75	2970	81															
VAPE1120/N2R	280	75	2970	83															
VAPE1120/N2R	280	90	2970	83															
VAPE1120/N2	280	90	2970	84															
VAPE1120/N2	315	110	2980	84															

VAPE/N

Il livello di pressione sonora ponderato A, LpA (cap.14), corrisponde al valore rilevato, nelle condizioni di prova, nel punto di massima rumorosità.

Tolleranza sulla rumorosità ±4dB(A)
 • Tolérance sur le bruit ±4dB(A) • Noise tolerance ±4dB(A)
 • Geräuschtoleranz ±4dB(A) • Tolerancia respecto a ruido ±4dB(A)

Q [m³/h]																		
1370	1440	1620	1800	2160	2520	2880	3240	3600	3960	4320	4680	5400	6120	7200	7920	9000	10800	12000
pt[mmH ₂ O]																		
559																		
648	647	637																
721																		
721	722	718	714															
816	820	825																
816	820	825	825	823	780													
914	917	923	928															
918	921	927	934	936	931	914												
1009	1019	1029	1036	1043	1058													
1009	1019	1029	1036	1043	1058	1049	1025											
1152	1156	1162	1176	1189	1198	1208	1208											
1152	1156	1162	1176	1189	1198	1208	1208	1198	1182	1167								
1254	1265	1274	1285	1305	1320	1328	1332	1335										
1254	1265	1274	1285	1305	1320	1328	1332	1335	1328	1320	1305							
		1427	1430	1460	1475	1490	1508	1514										
		1427	1430	1460	1475	1490	1508	1514	1516	1516	1504	1488						
			1583	1600	1615	1630	1650	1670	1682									
			1583	1600	1615	1630	1650	1670	1682	1685	1685	1682						
					1795	1805	1815	1830	1850	1865	1875	1885	1885					
					1795	1805	1815	1830	1850	1865	1875	1885	1885	1876	1850			
					1970	1980	2000	2020	2030	2040	2050	2060	2070	2080				
					1980	1990	2010	2030	2040	2050	2060	2070	2080	2090	2080	2070		
							2230	2255	2270	2282	2288	2311	2330	2353	2360			
							2230	2255	2270	2282	2288	2311	2330	2353	2360	2357	2330	2280
									2495	2515	2530	2560	2585	2610	2620			
									2510	2530	2545	2575	2600	2625	2635	2650	2640	2630

VAPE/N

■ Le niveau de pression sonore pondérée A, LpA (chap. 14), correspond à la valeur relevée dans les conditions d'essai au point de niveau sonore maximum.

■ The A-weighted sound power level, LpA (Chap.14), is the value measured in test conditions at the point of maximum noise level.

■ Der nach A bewertete Schalldruckpegel LpA (Kap. 14) entspricht in den Testbedingungen dem höchsten gemessenen Wert des Geräuschpegels.

■ El nivel de presión sonora ponderado A, LpA (cap. 14), corresponde al valor medido, en las condiciones de prueba, en el punto con máximos niveles de ruido.

Tipo • Type • Type • Typ • Tipo		P inst. [kW]	n	LpA [dB(A)]	Tolleranza sulla portata ±5% • Tolérance sur le débit ±5% • Load tolerance ±5% • Durchsatztoleranz ±5% • Tolerancia respecto caudal ±5%														
Ventilatore • Ventilateur • Fan • Ventilator • Ventilador	Motore • Moteur • Motor • Motor • Motor				Q [m³/h]														
					285	360	400	430	470	540	650	720	790	865	935	1080	1225		
					pt[mmH ₂ O]														
VAPE400/N2	71	0,55	2845	56	287	292	292	291	287										
VAPE400/N2	80	0,75	2845	57	287	292	292	291	287	281	263								
VAPE450/N2	80	1,1	2845	58	358	362	366	368	368	368	364	357							
VAPE450/N2	90	1,5	2860	58	360	365	367	369	369	369	366	360	354	343					
VAPE500/N2R	90	1,5	2860	59	402	406	409	411	412	414	415	413	409	405	398				
VAPE500/N2	90	2,2	2920	60	451	460	462	463	464	469	470	471	472	469	462	452			
VAPE560/N2R	90	2,2	2920	61				513	516	520	525	527	528	528	528				
VAPE560/N2R	100	3	2920	62				513	516	520	525	527	528	528	528	523	516		
VAPE560/N2	100	3	2920	63				565	566	571	576	580	582	583	584	585	580		
VAPE560/N2	112	4	2950	64				573	575	580	585	588	591	591	593	594	591		
VAPE630/N2R	112	4	2950	64						637	643	645	651	653	655	660	660		
VAPE630/N2R	132	5,5	2950	65						637	643	645	651	653	655	660	660		
VAPE630/N2	132	5,5	2950	66								725	731	736	738	738	739		
VAPE630/N2	132	7,5	2950	67								725	731	736	738	738	739		
VAPE710/N2R	132	7,5	2950	69								803	807	810	814	819	825		
VAPE710/N2R	160	11	2960	70								807	810	813	817	823	829		
VAPE710/N2	160	11	2960	72											896	898	899		
VAPE710/N2	160	15	2960	72											896	898	899		
VAPE800/N2R	160	15	2960	73															
VAPE800/N2R	160	18,5	2960	74															
VAPE800/N2	160	18,5	2960	75															
VAPE800/N2	180	22	2960	75															
VAPE900/N2R	180	22	2960	76															
VAPE900/N2R	200	30	2960	76															
VAPE900/N2	200	30	2960	78															
VAPE900/N2	200	37	2960	78															
VAPE1000/N2R	225	45	2960	79															
VAPE1000/N2R	250	55	2960	79															
VAPE1000/N2	250	55	2960	80															
VAPE1000/N2	280	75	2970	80															
VAPE1120/N2R	280	75	2970	81															
VAPE1120/N2R	280	90	2970	81															
VAPE1120/N2	280	90	2970	82															
VAPE1120/N2	315	110	2980	82															

Il livello di pressione sonora ponderato A, LpA (cap.14), corrisponde al valore rilevato, nelle condizioni di prova, nel punto di massima rumorosità.

Tolleranza sulla rumorosità ±4dB(A)
 • Tolérance sur le bruit ±4dB(A) • Noise tolerance ±4dB(A)
 • Geräuschtoleranz ±4dB(A) • Tolerancia respecto a ruido ±4dB(A)

Q [m³/h]																		
1370	1440	1620	1800	2160	2520	2880	3240	3600	3960	4320	4680	5400	6120	7200	7920	9000	10800	12000
pt[mmH ₂ O]																		
504																		
584	580	564																
658																		
658	658	650	641															
741	743	743																
741	743	743	738	724	673													
830	832	834	835															
834	835	837	840	835	822	797												
910	917	923	926	924	928													
910	917	923	926	924	928	911	880											
1031	1034	1037	1046	1053	1055	1057	1051											
1031	1034	1037	1046	1053	1055	1057	1051	1035	1014	993								
1113	1121	1127	1134	1145	1152	1153	1150	1145										
1113	1121	1127	1134	1145	1152	1153	1150	1145	1132	1117	1095							
		1249	1250	1271	1280	1288	1297	1298										
		1249	1250	1271	1280	1288	1297	1298	1294	1289	1274	1249						
			1367	1377	1386	1394	1405	1416	1420									
			1367	1377	1386	1394	1405	1416	1420	1417	1412	1397						
					1523	1528	1533	1541	1552	1560	1564	1563	1555					
					1523	1528	1533	1541	1552	1560	1564	1563	1555	1533	1502			
					1648	1653	1665	1676	1681	1685	1688	1688	1687	1679				
					1655	1660	1672	1684	1688	1692	1695	1695	1694	1686	1668	1642		
							1827	1843	1851	1857	1859	1870	1878	1884	1882			
							1827	1843	1851	1857	1859	1870	1878	1884	1882	1868	1826	1774
									2000	2011	2019	2034	2045	2053	2053			
									2010	2021	2029	2044	2055	2062	2062	2061	2033	2010

VAPE/N

■ Le niveau de pression sonore pondérée A, LpA (chap. 14), correspond à la valeur relevée dans les conditions d'essai au point de niveau sonore maximum.

■ The A-weighted sound power level, LpA (Chap. 14), is the value measured in test conditions at the point of maximum noise level.

■ Der nach A bewertete Schalldruckpegel LpA (Kap. 14) entspricht in den Testbedingungen dem höchsten gemessenen Wert des Geräuschpegels.

■ El nivel de presión sonora ponderado A, LpA (cap. 14), corresponde al valor medido, en las condiciones de prueba, en el punto con máximos niveles de ruido.

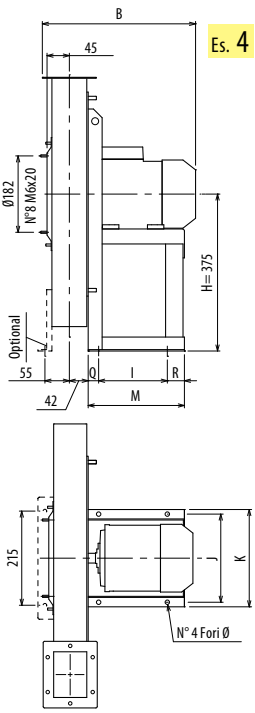

Es. 4

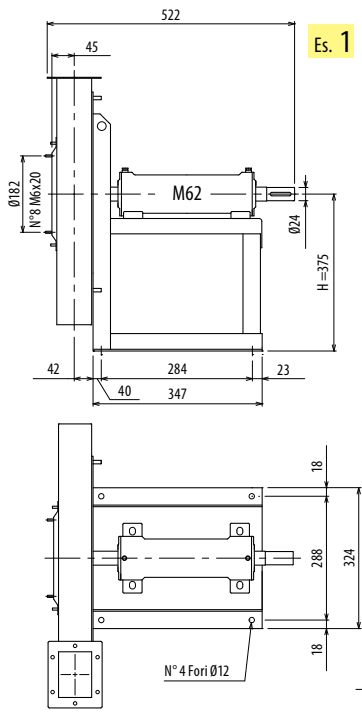

Es. 1

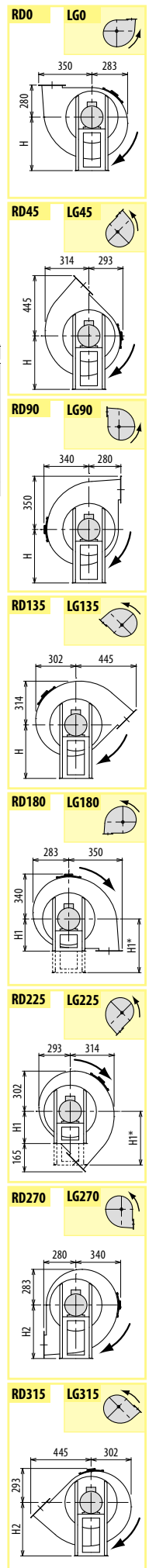
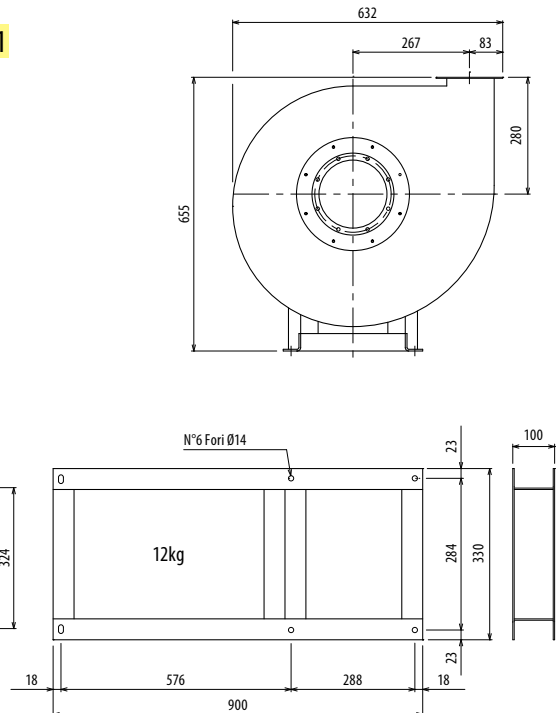

Il ventilatore è orientabile • Peso in tabella comprensivo di motore

- Le ventilateur est orientable
 - The fan is revolvable
 - Der Ventilator ist drehbar
 - El ventilador es orientable
- Le poids dans le tableau inclut le moteur The weight indicated in the table includes motor Das Gewicht im Tafel schließt den Motor ein El peso en la tabla incluye el motor

Ulteriori informazioni e quote:
■ Ulérieures informations et cotes:
■ Further information and sizes:
■ Weitere Infos und Größen:
■ Más informaciones y medidas:

TIPO - Type		PESO Weight	PD ²											
VENTILATORE Fan	MOTORE Motor	Kg	Kgf x m ²	B	I	H	H1	H2	J	K	M	Q	R	Ø
VAPE400/N2	71 B2	51	0,6	344	121	375	375*	375	203	225	196	49	26	10
VAPE400/N2	80 A2	55	0,6	344	121	375	375*	375	203	225	211	45	45	10
VAPE400/N/T		40	0,60			375	280	375						

pg. / s. 4,6
pg. / s. 4,5

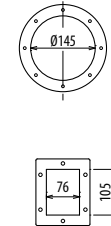

VAPE/N

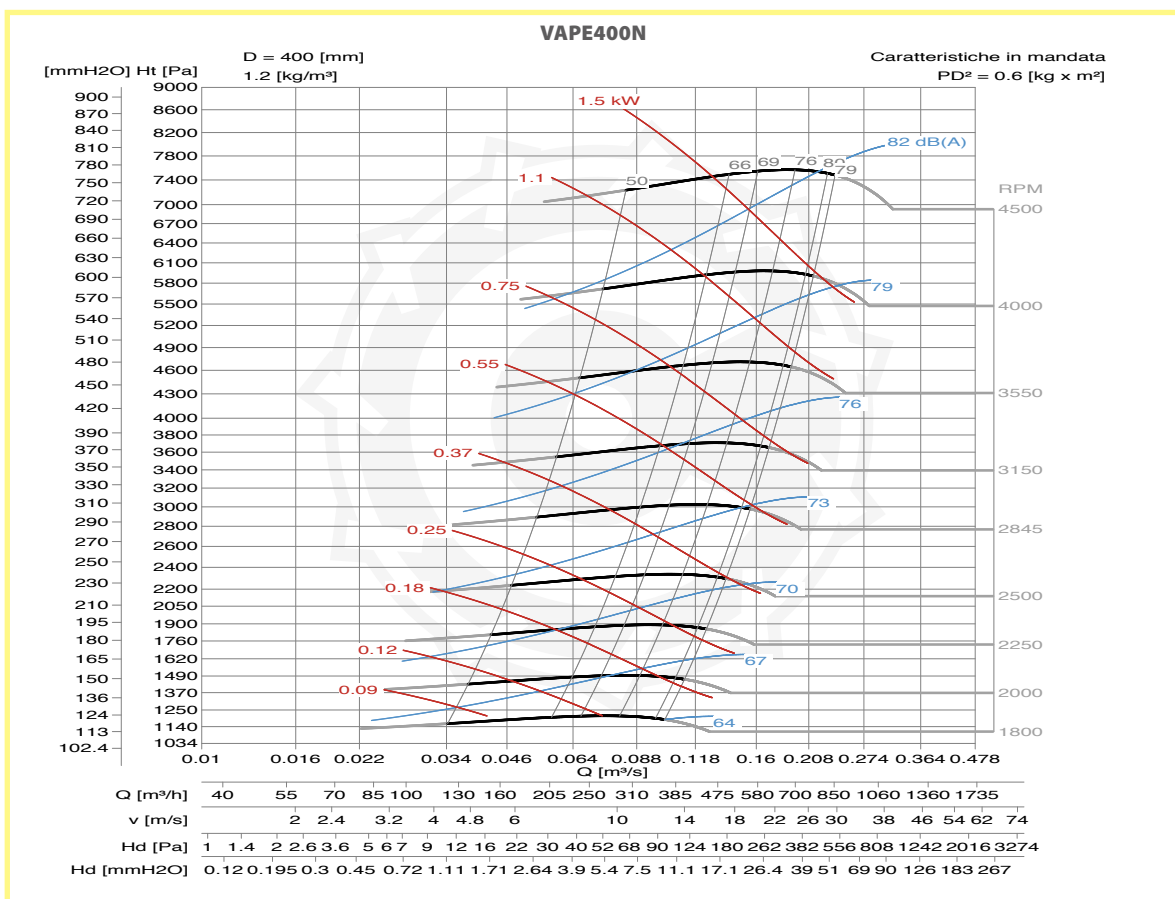

DIMENSIONI D'INGOMBRO E PESI/CURVE DI FUNZIONAMENTO

■ DIMENSIONS D'ENCOMBREMENT ET POIDS/COURBES DE FONCTIONNEMENT ■ OVERALL DIMENSIONS AND WEIGHT/WORKING CURVES
 ■ AUSMARE UND GEWICHTE/FUNKTIONSKURVEN ■ DIMENSIONES QUE OCUPA Y PESOS/CURVAS DE FUNCIONAMIENTO

VAPE450/N

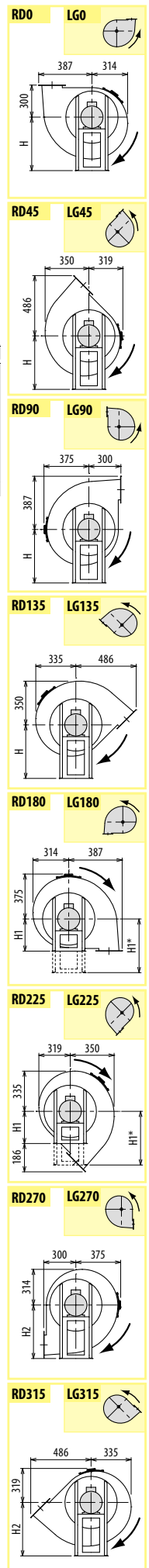
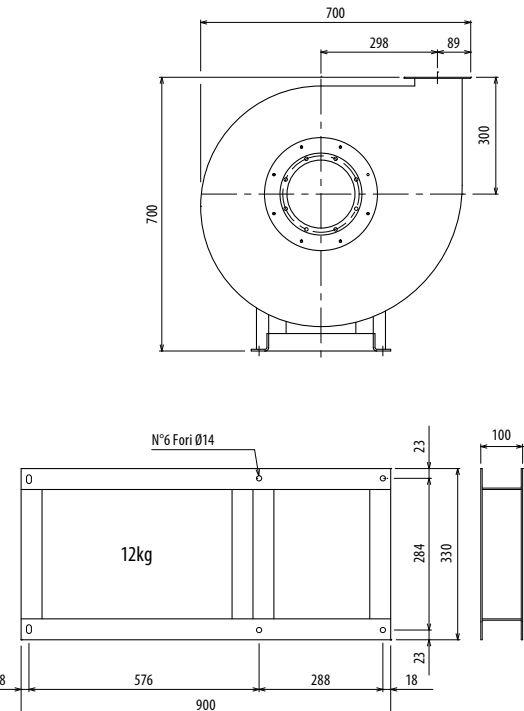
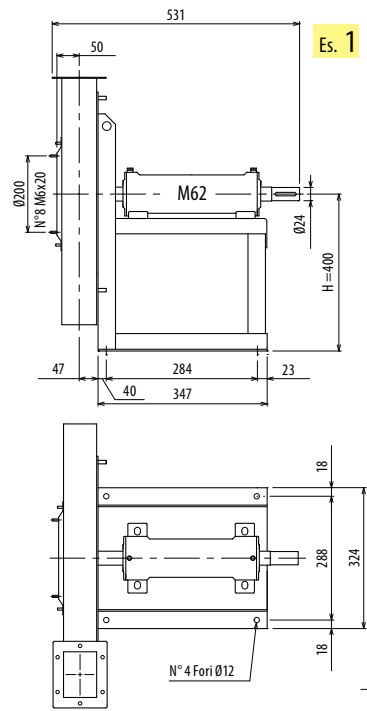
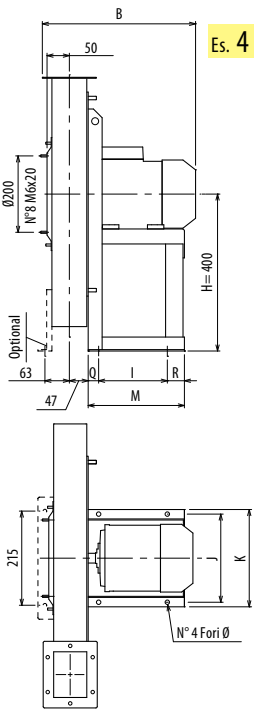

Il ventilatore è orientabile - Peso in tabella comprensivo di motore

- Le ventilateur est orientable
 - The fan is revolvable
 - Der Ventilator ist drehbar
 - El ventilador es orientable
- Le poids dans le tableau inclut le moteur The weight indicated in the table includes motor Das Gewicht in Tafel schließt den Motor ein El peso en la tabla incluye el motor

Ulteriori informazioni e quote:
 ■ Ulérieures informations et cotes:
 ■ Further information and sizes:
 ■ Weitere Infos und Größen:
 ■ Más informaciones y medidas:

TIPO - Type		PESO Weight Kg	PD² Kgf x m²	B	I	H	H1	H2	J	K	M	Q	R	Ø
VENTILATORE Fan	MOTORE Motor													
VAPE450/N2	80 B2	61	0,9	353	121	400	400*	400	203	225	211	45	45	10
VAPE450/N2	90 L2	67	0,9	400	133	400	400*	400	234	260	246	55	58	10
VAPE450/N/T		65	0,9			400	300	400						

pg. / s. 4,6
 pg. / s. 4,5

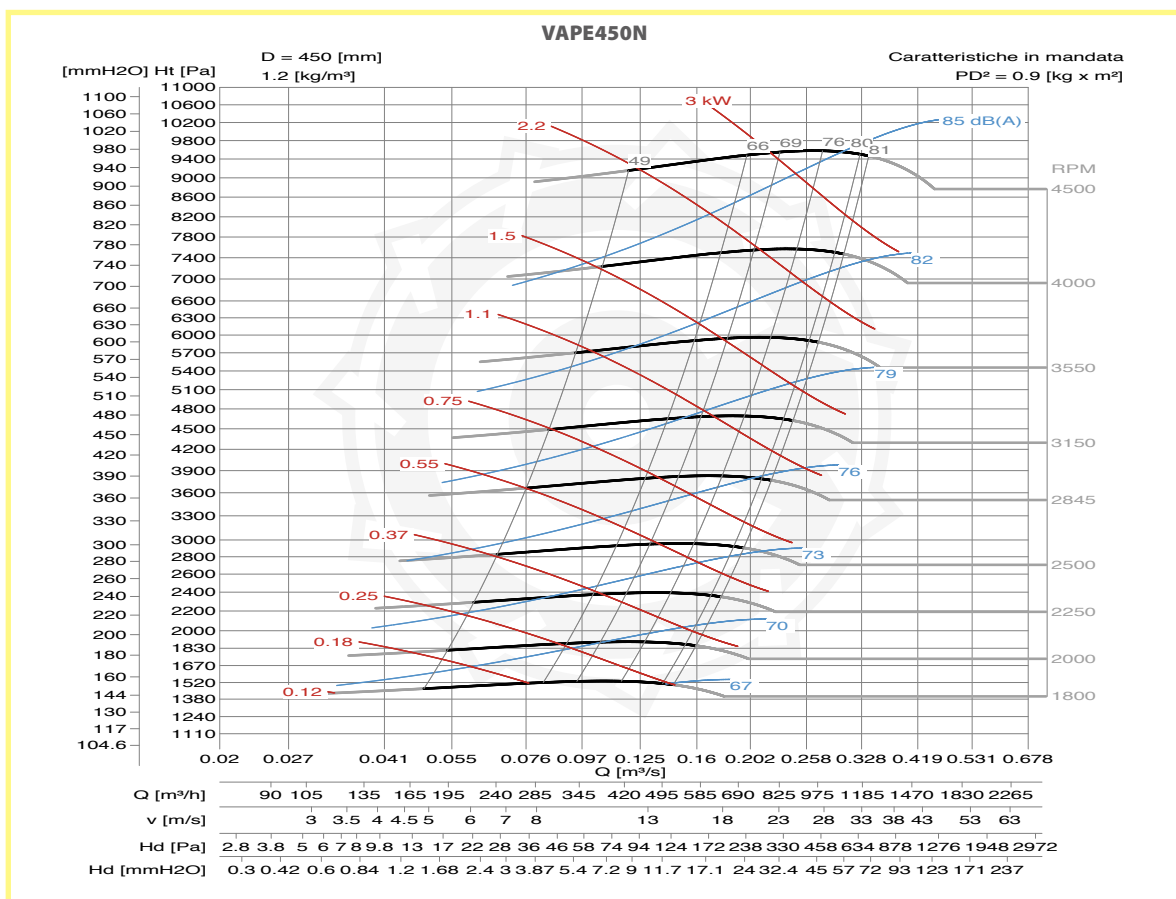
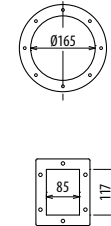

VAPE/N

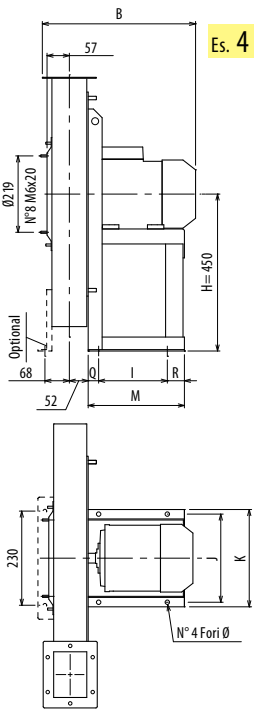

Es. 4

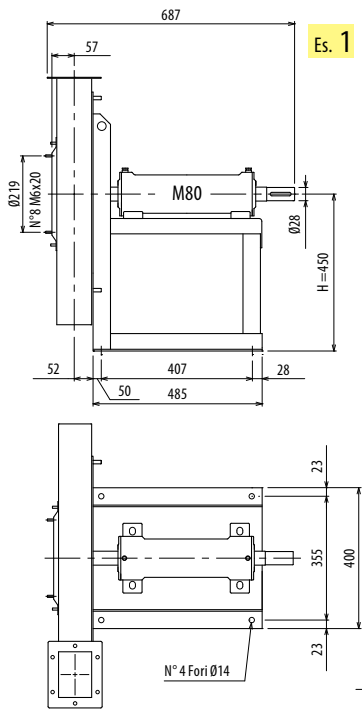

Es. 1

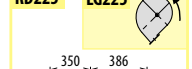
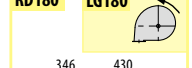
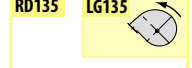
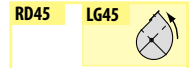
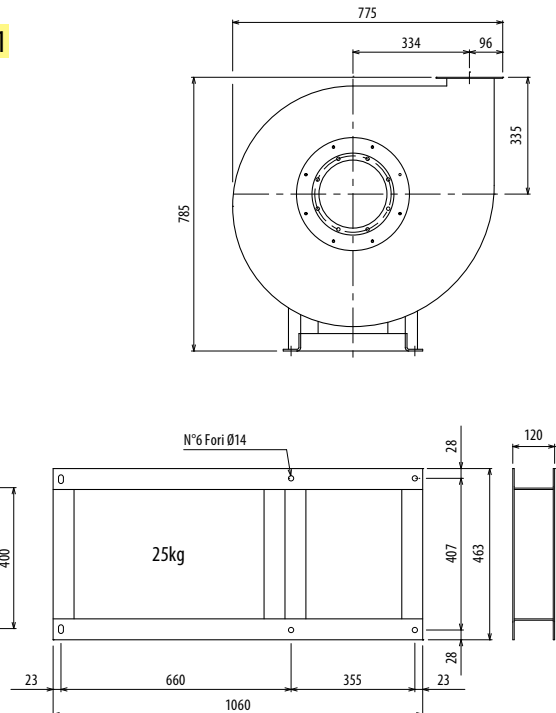

Il ventilatore è orientabile • Peso in tabella comprensivo di motore

- Le ventilateur est orientable
 - The fan is revolvable
 - Der Ventilator ist drehbar
 - El ventilador es orientable
- Le poids dans le tableau inclut le moteur The weight indicated in the table includes motor Das Gewicht im Tafel schließt den Motor ein El peso en la tabla incluye el motor

Ulteriori informazioni e quote:
■ Ulérieures informations et cotes:
■ Further information and sizes:
■ Weitere Infos und Größen:
■ Más informaciones y medidas:

TIPO - Type		PESO Weight Kg	PD ² Kg x m ²	B	I	H	H1	H2	J	K	M	Q	R	Ø
VENTILATORE Fan	MOTORE Motor													
VAPE500/N2R	90 S2	71	1,4	410	133	450	450*	450	234	260	246	55	58	10
VAPE500/N2	90 L2	75	1,6	410	133	450	450*	450	234	260	246	55	58	10
VAPE500/N/T		80	1,6			450	335	450						

pg. / s. 4,6

pg. / s. 4,5

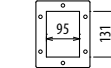
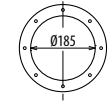

VAPE/N

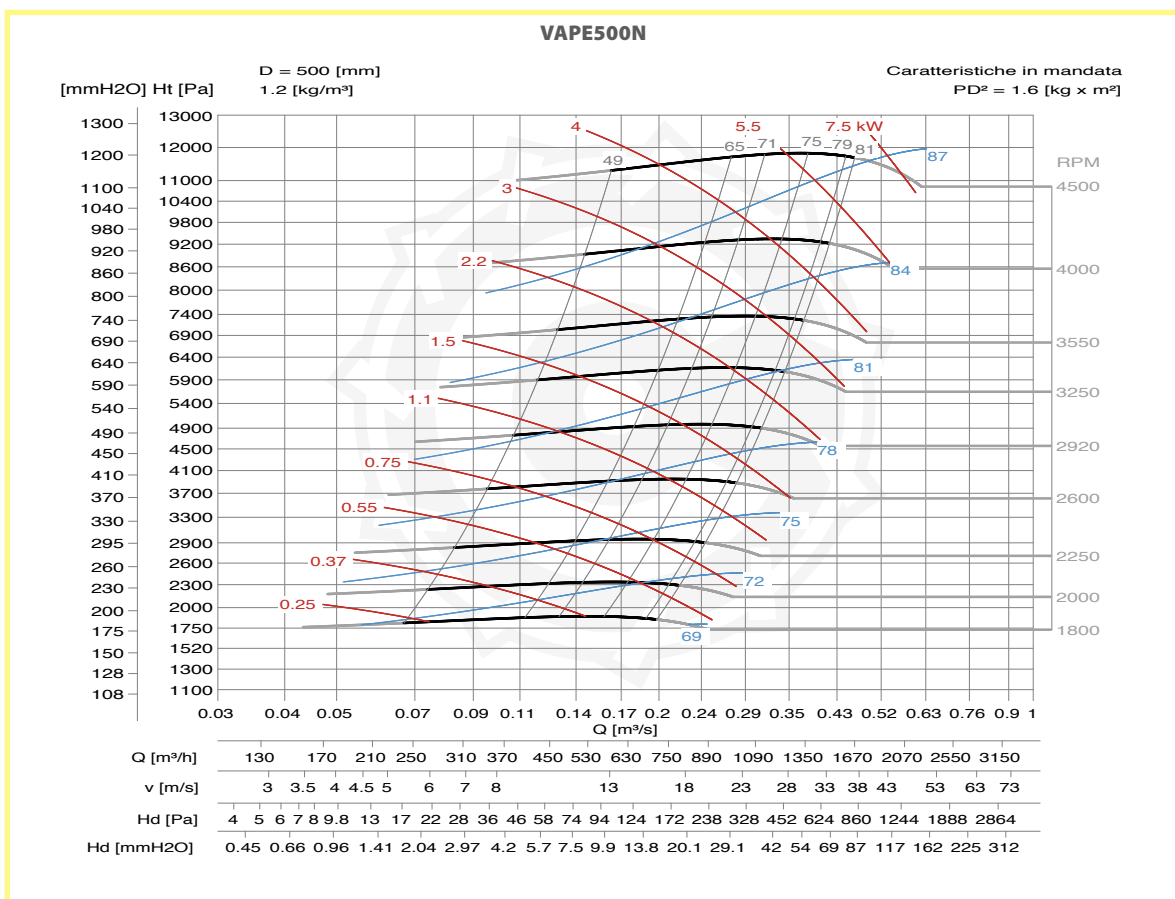

DIMENSIONI D'INGOMBRO E PESI/CURVE DI FUNZIONAMENTO

■ DIMENSIONS D'ENCOMBREMENT ET POIDS/COURBES DE FONCTIONNEMENT ■ OVERALL DIMENSIONS AND WEIGHT/WORKING CURVES
 ■ AUSMAßE UND GEWICHTE/FUNKTIONSKURVEN ■ DIMENSIONES QUE OCUPA Y PESOS/CURVAS DE FUNCIONAMIENTO

VAPE560/N

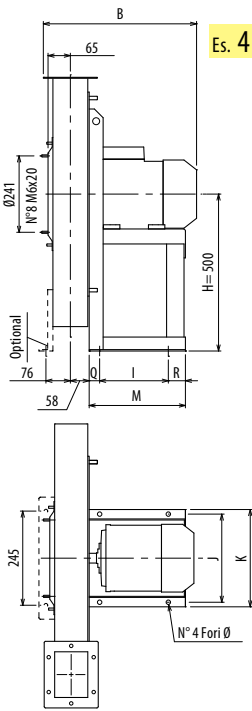

Es. 4

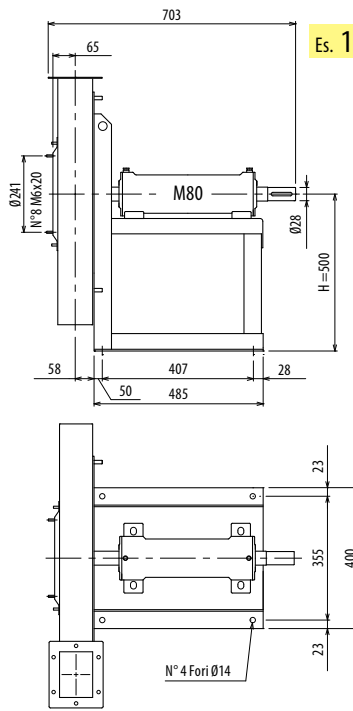

Es. 1

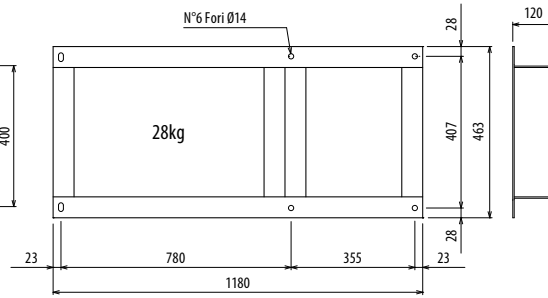
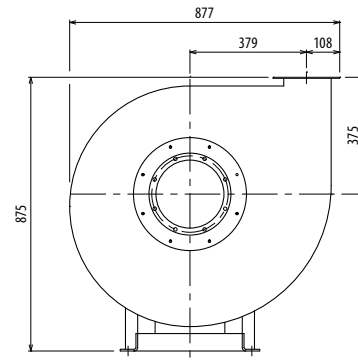

Il ventilatore è orientabile • Peso in tabella comprensivo di motore

- Le ventilateur est orientable
 - The fan is revolvable
 - Der Ventilator ist drehbar
 - El ventilador es orientable
- Le poids dans le tableau inclut le moteur The weight indicated in the table includes motor Das Gewicht in Tafel schließt den Motor ein El peso en la tabla incluye el motor

Ulteriori informazioni e quote:
 ■ Ulérieures informations et cotes:
 ■ Further information and sizes:
 ■ Weitere Infos und Größen:
 ■ Más informaciones y medidas:

TIPO - Type		PESO Weight	PD ²	B	I	H	H1	H2	J	K	M	Q	R	Ø
VENTILATORE Fan	MOTORE Motor	Kg	Kgf x m ²											
VAPE560/N2R	90 L2	86	2	426	133	500	500*	500	234	260	246	55	58	10
VAPE560/N2R	100 L2	98	2	457	197	500	500*	500	289	324	276	30	49	12
VAPE560/N2	100 L2	99	2,4	457	197	500	500*	500	289	324	276	30	49	12
VAPE560/N2	112 M2	107	2,4	478	197	500	500*	500	289	324	276	30	49	12
VAPE560/N/T		100	2,4			500	375	500						

pg. / s. 4,6

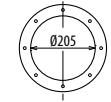

pg. / s. 4,5

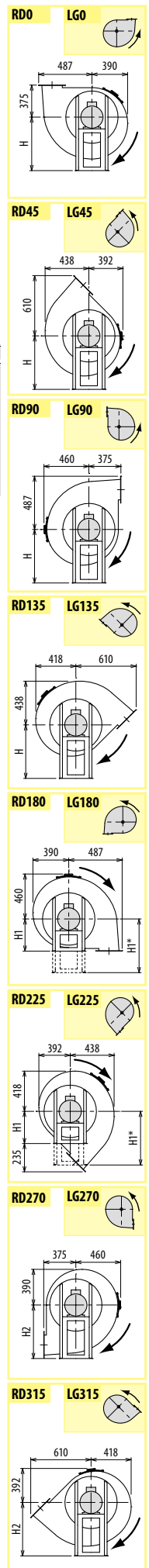

VAPE/N

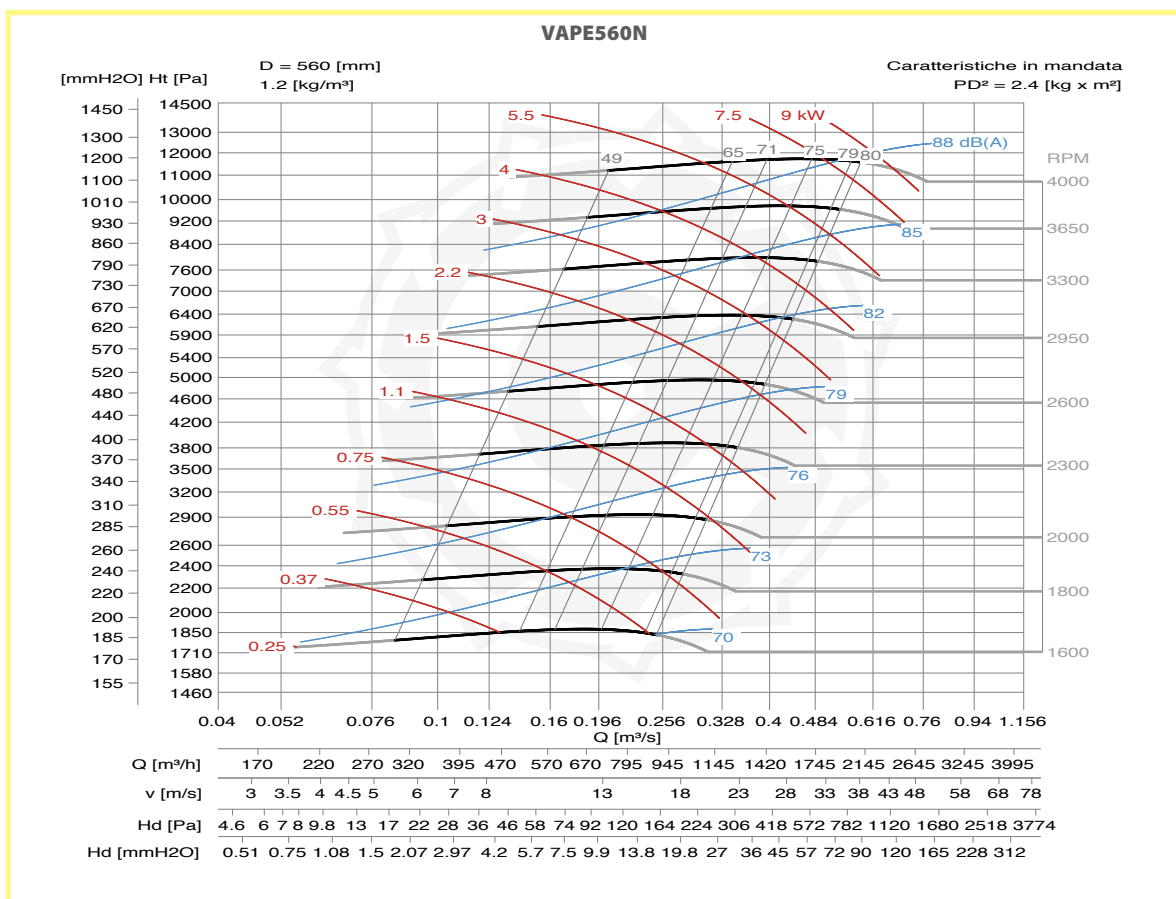

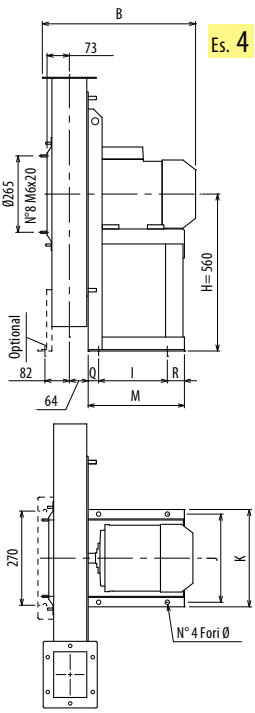

Es. 4

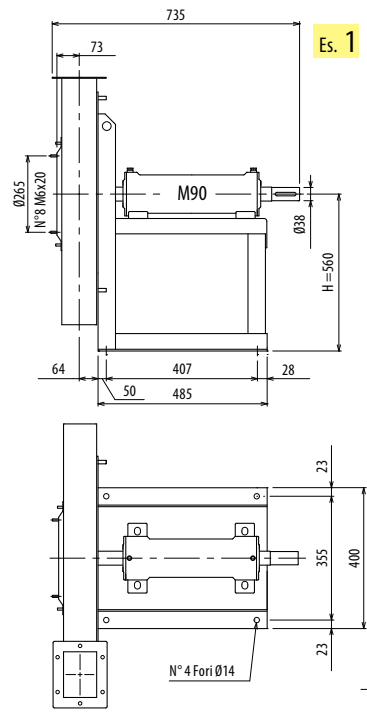

Es. 1

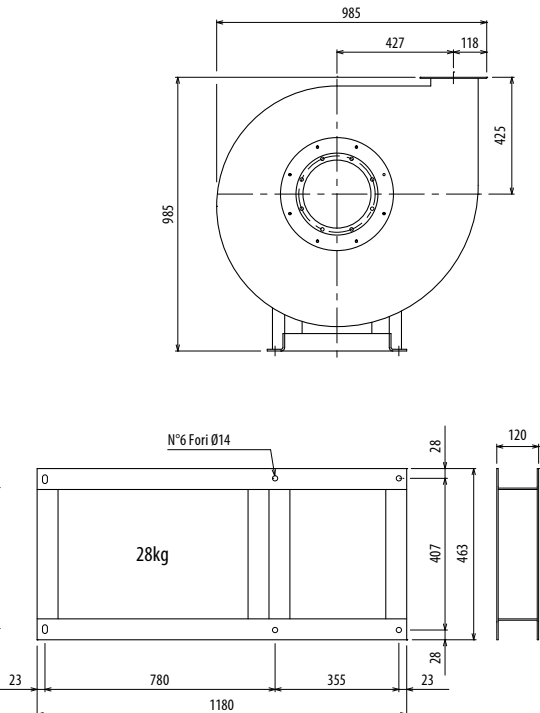

Il ventilatore è orientabile • Peso in tabella comprensivo di motore

- Le ventilateur est orientable
 - The fan is revolvable
 - Der Ventilator ist drehbar
 - El ventilador es orientable
- Le poids dans le tableau inclut le moteur The weight indicated in the table includes motor Das Gewicht in Tafel schließt den Motor ein El peso en la tabla incluye el motor

Ulteriori informazioni e quote:
■ Ulérieures informations et cotes:
■ Further information and sizes:
■ Weitere Infos und Größen:
■ Más informaciones y medidas:

TIPO - Type		PESO Weight	PD ²											
VENTILATORE Fan	MOTORE Motor	Kg	Kgf x m ²	B	I	H	H1	H2	J	K	M	Q	R	Ø
VAPE630/N2R	112 M2	131	3	490	197	560	560*	560	289	324	276	30	49	12
VAPE630/N2R	132 SA2	143	3	530	237	560	560*	560	337	372	336	40	59	12
VAPE630/N2	132 SA2	145	4	530	237	560	560*	560	337	372	336	40	59	12
VAPE630/N2	132 SB2	145	4	530	237	560	560*	560	337	372	336	40	59	12
VAPE630/N/T		133	4,0			560	425	560						

pg. / s. 4,6
pg. / s. 4,5

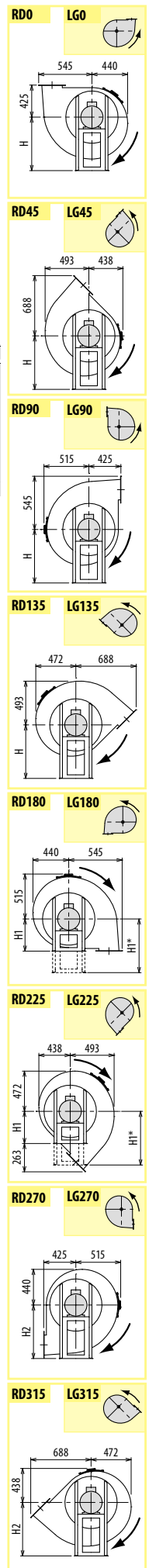
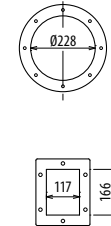

VAPE/N

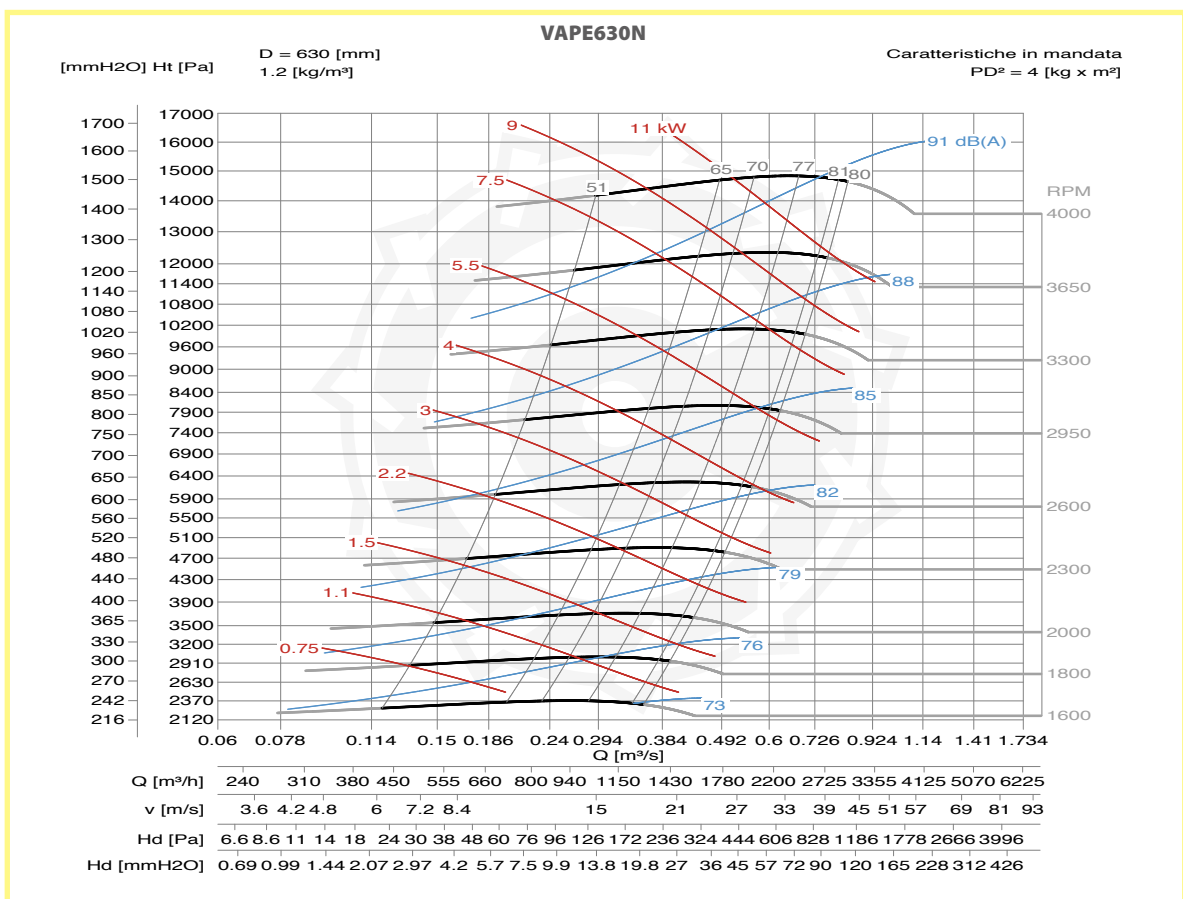

DIMENSIONI D'INGOMBRO E PESI/CURVE DI FUNZIONAMENTO

■ DIMENSIONS D'ENCOMBREMENT ET POIDS/COURBES DE FONCTIONNEMENT ■ OVERALL DIMENSIONS AND WEIGHT/WORKING CURVES
 ■ AUSMAßE UND GEWICHTE/FUNKTIONSKURVEN ■ DIMENSIONES QUE OCUPA Y PESOS/CURVAS DE FUNCIONAMIENTO

VAPE710/N

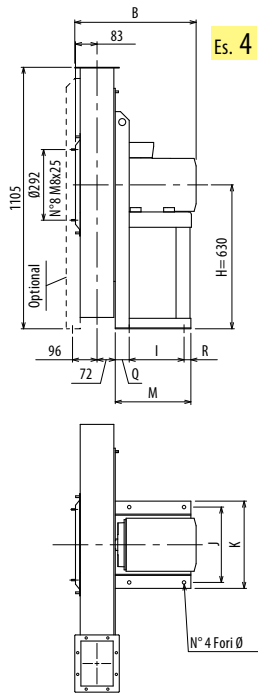

Es. 4

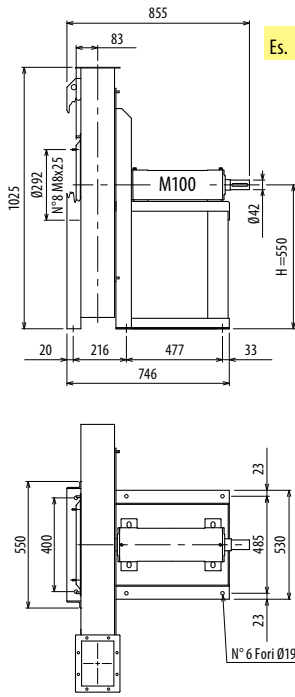

Es. 1

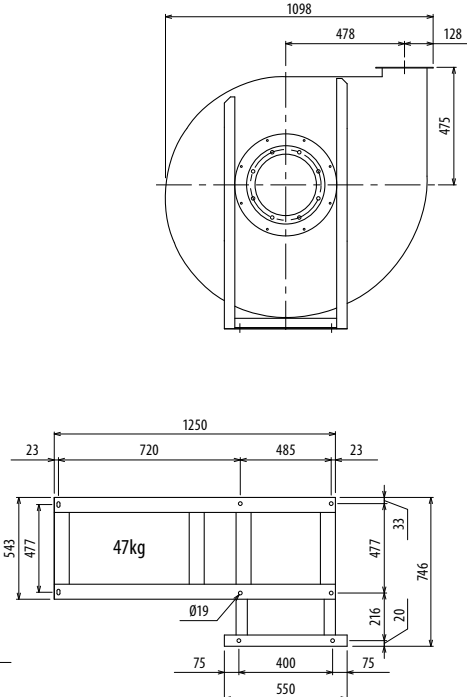

Il ventilatore in Es. 4 senza supporto anteriore è orientabile, in Es. 1 non è orientabile • Peso in tabella comprensivo di motore

- Le ventilateur en Ex. 4 sans support frontal est orientable, en Ex. 1 n'est pas orientable. ■ The fan in Ex. 4 without front support is revolvable, in Ex. 1 is not revolvable. Le poids dans le tableau inclut le moteur The weight indicated in the table includes motor
- Der Ventilator in Aus. 4, ohne Vorderhalterung, ist drehbar; in Aus. 1 ist nicht drehbar. ■ El ventilador en Ej. 4 sin soporte delantero es orientable, en Ej. 1 no es orientable. El peso en la tabla incluye el motor

Ulteriori informazioni e quote:
 ■ Ulérieures informations et cotes:
 ■ Further information and sizes:
 ■ Weitere Infos und Größen:
 ■ Más informaciones y medidas:

TIPO - Type		PESO Weight	PD ²	B	I	H	H1	H2	J	K	M	Q	R	Ø
VENTILATORE Fan	MOTORE Motor	Kg	Kgf x m ²											
VAPE710/N2R	132 SB2	205	6	545	237	630*	630*	630	337	372	336	40	59	12
VAPE710/N2R	160 MA2	218	6	650	337	630*	630*	630	395	440	436	50	49	14
VAPE710/N2	160 MA2	222	7	650	337	630*	630*	630	395	440	436	50	49	14
VAPE710/N2	160 MB2	222	7	650	337	630*	630*	630	395	440	436	50	49	14
VAPE710/N/T		183	7			550	475	630						

pg. / s. 4,6
 pg. / s. 4,5

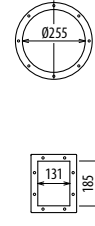

RD0 LG0

RD45 LG45

RD90 LG90

RD135 LG135

RD180 LG180

RD225 LG225

RD270 LG270

RD315 LG315

VAPE/N

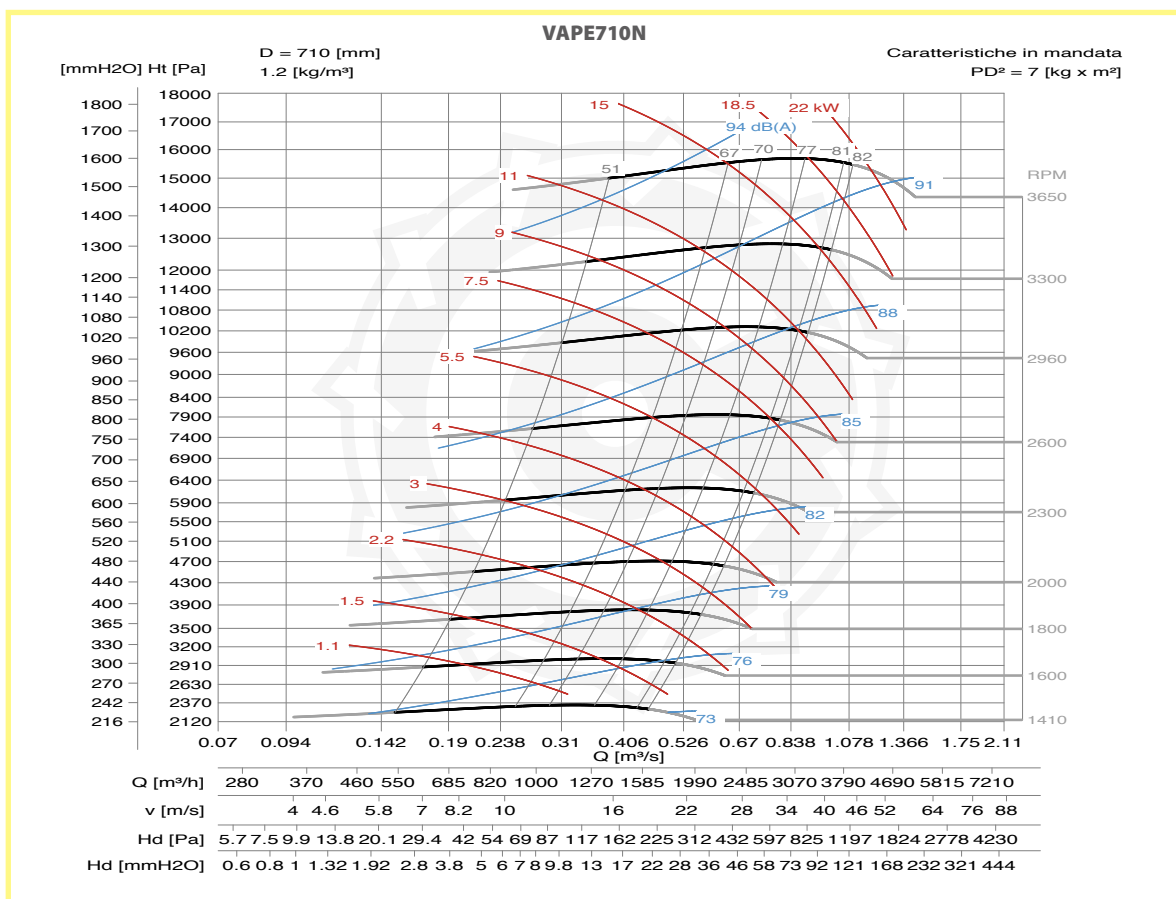

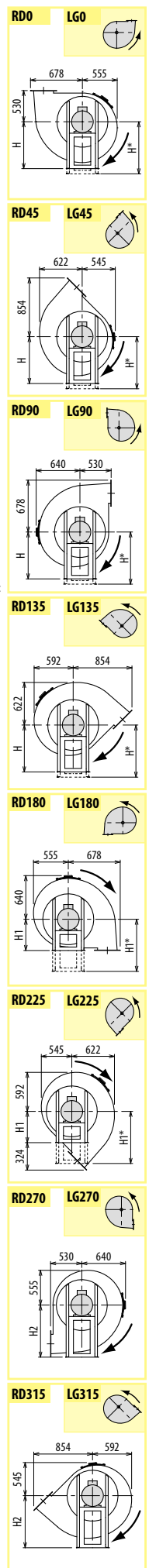
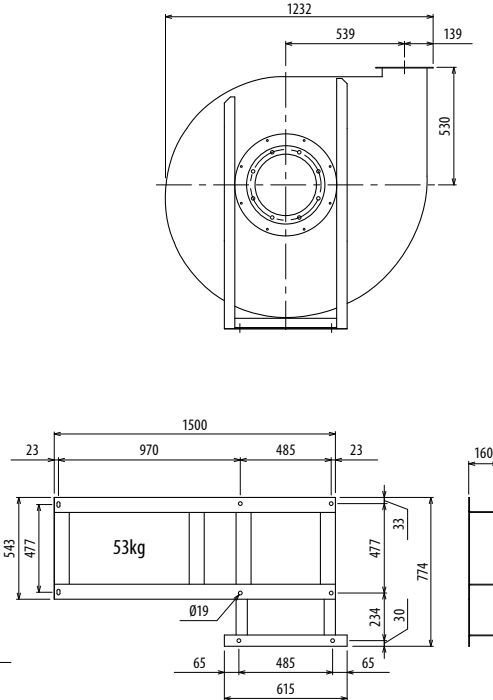
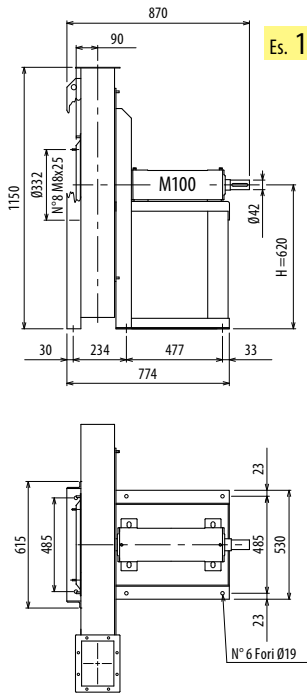
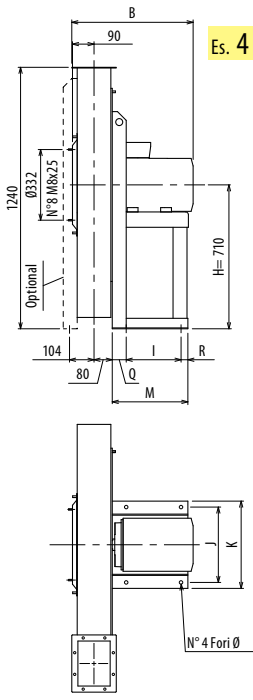

Il ventilatore in Es. 4 senza supporto anteriore è orientabile, in Es. 1 non è orientabile • Peso in tabella comprensivo di motore

- Le ventilateur en Ex. 4 sans support frontal est orientable, en Ex. 1 n'est pas orientable. ■ The fan in Ex. 4 without front support is revolvable, in Ex. 1 is not revolvable.
- Le poids dans le tableau inclut le moteur The weight indicated in the table includes motor
- Der Ventilator in Aus. 4, ohne Vorderhalterung, ist drehbar; in Aus. 1 ist nicht drehbar. ■ El ventilador en Ej. 4 sin soporte delantero es orientable, en Ej. 1 no es orientable.
- Gewichtsgabe in Tabelle inkl. Motor El peso en la tabla incluye el motor

Ulteriori informazioni e quote:
■ Ulérieures informations et cotes:
■ Further information and sizes:
■ Weitere Infos und Größen:
■ Más informaciones y medidas:

TIPO - Type		PESO Weight	PD²	B	I	H	H1	H2	J	K	M	Q	R	Ø	pg. / s. 4,6
VENTILATORE Fan	MOTORE Motor														
VAPE800/N2R	160 MB2	256	10	667	337	710*	710*	710	395	440	436	50	49	14	pg. / s. 4,5
VAPE800/NZR	160 L2	268	10	667	337	710*	710*	710	395	440	436	50	49	14	
VAPE800/N2	160 L2	280	13	667	337	710*	710*	710	395	440	436	50	49	14	
VAPE800/N2	180 M2	336	13	748	357	710*	710*	710	434	488	460	70	33	17	
VAPE800/N/T		218	13			620	530	710							

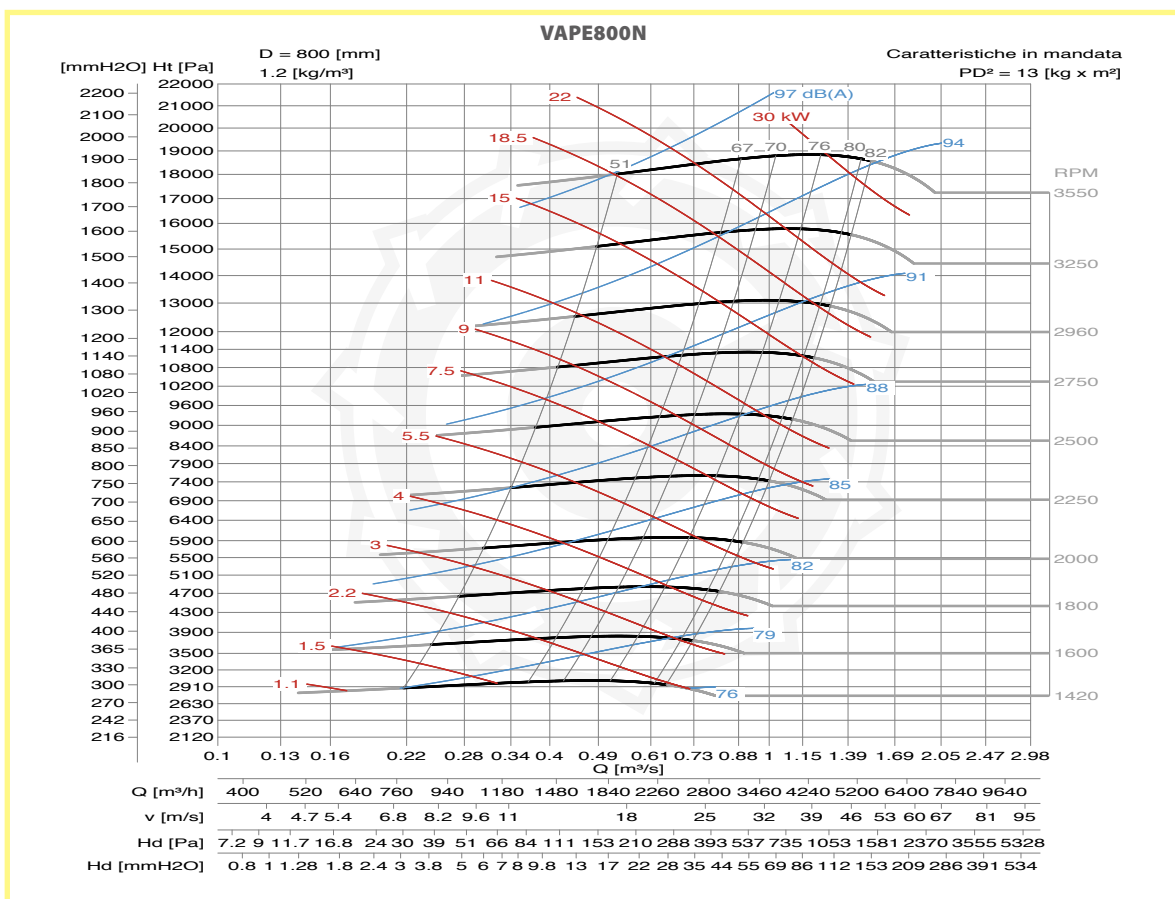

DIMENSIONI D'INGOMBRO E PESI/CURVE DI FUNZIONAMENTO

■ DIMENSIONS D'ENCOMBREMENT ET POIDS/COURBES DE FONCTIONNEMENT ■ OVERALL DIMENSIONS AND WEIGHT/WORKING CURVES
 ■ AUSMAßE UND GEWICHTE/FUNKTIONSKURVEN ■ DIMENSIONES QUE OCUPA Y PESOS/CURVAS DE FUNCIONAMIENTO

VAPE900/N

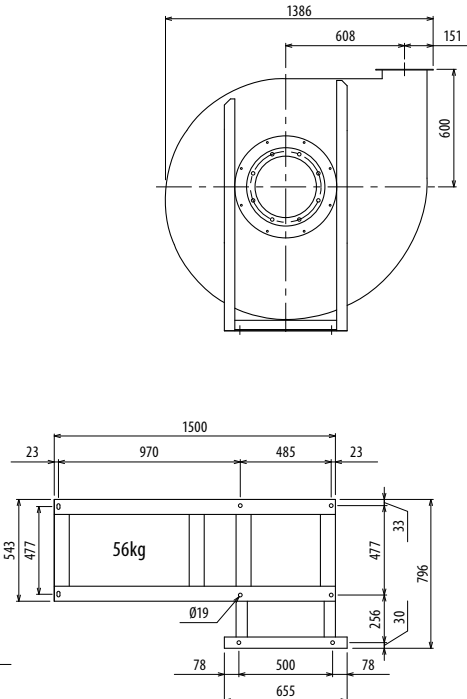
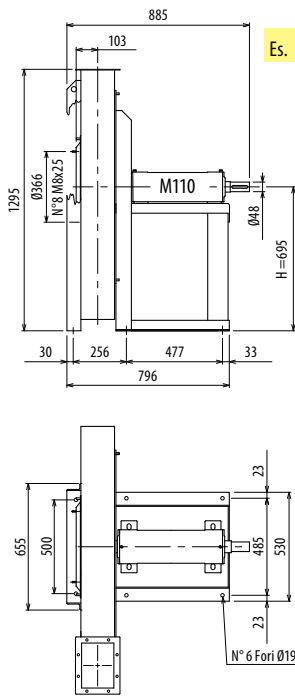
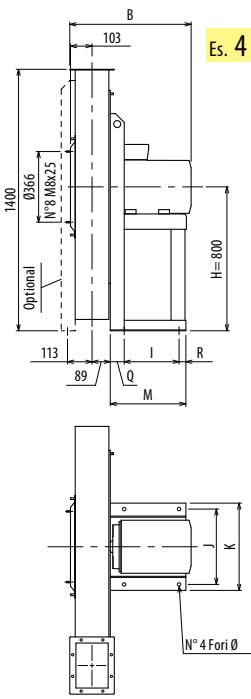

Il ventilatore in ES. 4 senza supporto anteriore è orientabile, in ES. 1 non è orientabile • Peso in tabella comprensivo di motore

- Le ventilateur en Ex. 4 sans support frontal est orientable, en Ex. 1 n'est pas orientable. ■ The fan in Ex. 4 without front support is revolvable, in Ex. 1 is not revolvable.
- Le poids dans le tableau inclut le moteur The weight indicated in the table includes motor
- Der Ventilator in Aus. 4, ohne Vorderhalterung, ist drehbar; in Aus. 1 ist nicht drehbar. ■ El ventilador en Ej. 4 sin soporte delantero es orientable, en Ej. 1 no es orientable.
- Gewichtsangabe in Tabelle inkl. Motor El peso en la tabla incluye el motor

Ulteriori informazioni e quote:
 ■ Ulérieures informations et cotes:
 ■ Further information and sizes:
 ■ Weitere Infos und Größen:
 ■ Más informaciones y medidas:

TIPO - Type		PESO Weight	PD ²	B	I	H	H1	H2	J	K	M	Q	R	Ø
VENTILATORE Fan	MOTORE Motor													
VAPE900/N2R	180 M2	416	17	766	357	800*	800*	800	434	488	460	70	33	17
VAPE900/N2R	200 LA2	442	17	874	381	800*	800*	800	506	568	500	80	39	19
VAPE900/N2	200 LA2	508	21	874	381	800*	800*	800	506	568	500	80	39	19
VAPE900/N2	200 LB2	508	21	874	381	800*	800*	800	506	568	500	80	39	19
VAPE900/N/T		320	21			695	600	800						

pg. / s. 4,6
 pg. / s. 4,5

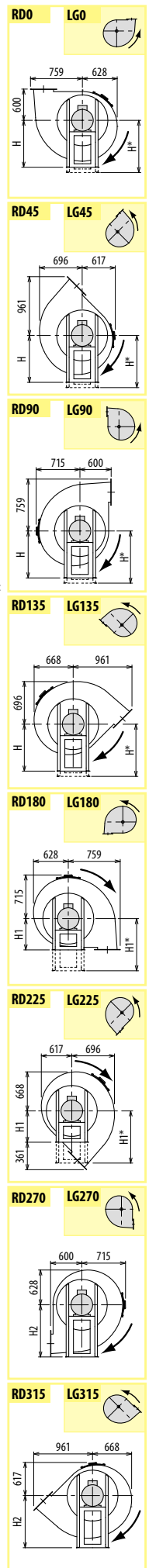
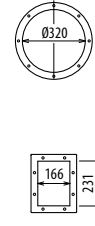

VAPE/N

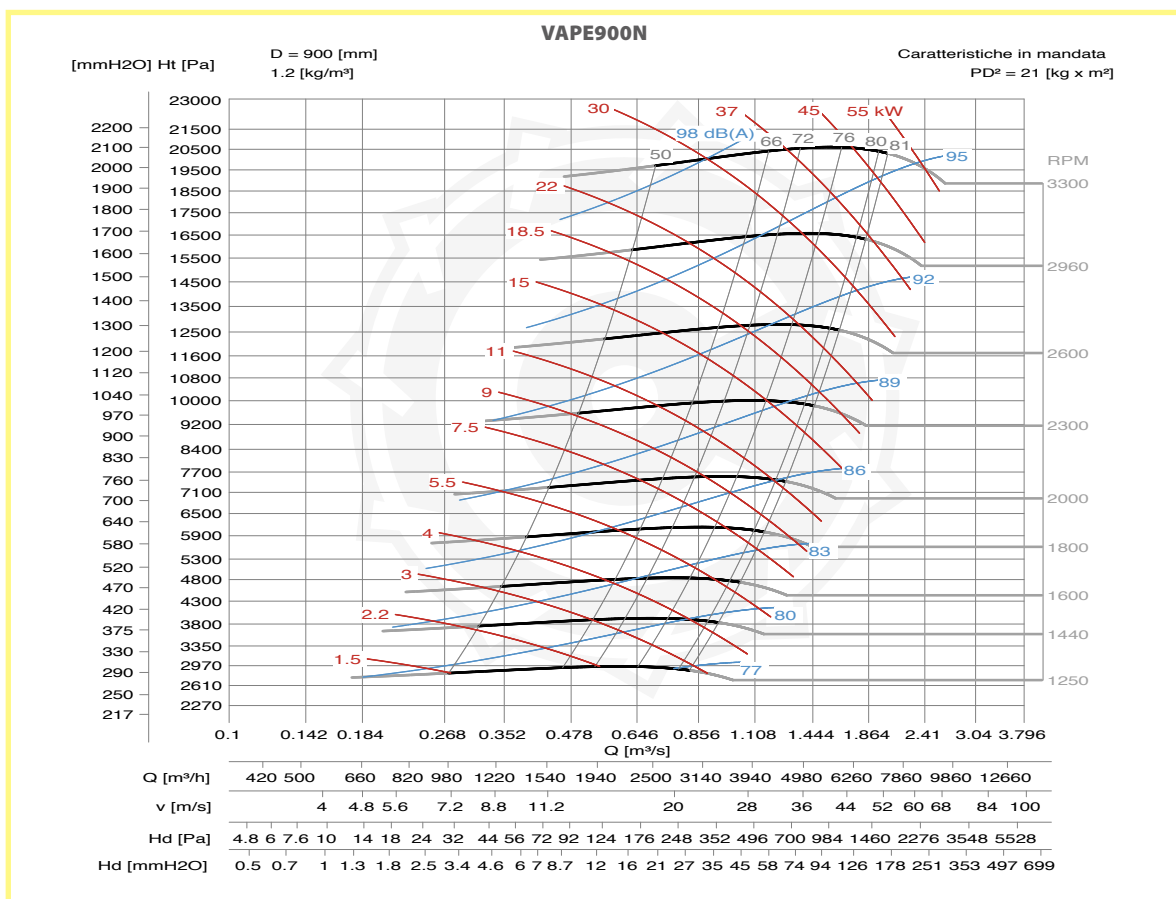

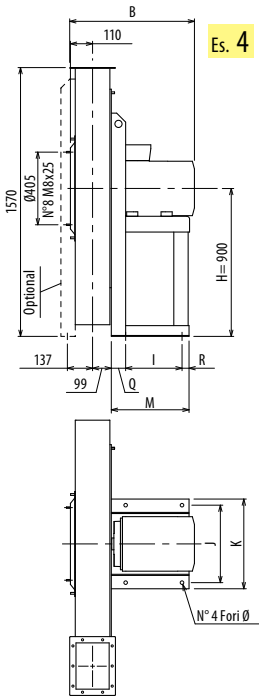

Es. 4

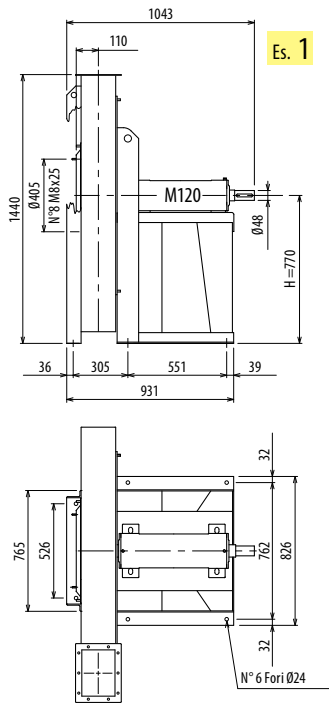

Es. 1

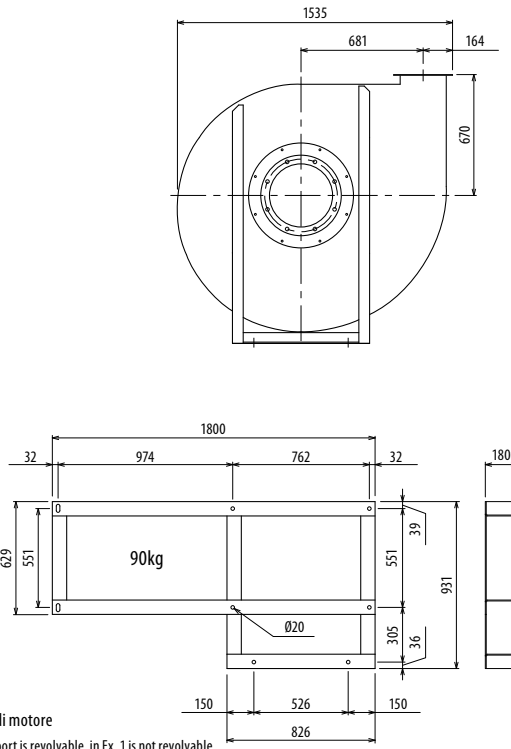

Il ventilatore in ES. 4 senza supporto anteriore è orientabile, in ES. 1 non è orientabile • Peso in tabella comprensivo di motore

- Le ventilateur en Ex. 4 sans support frontal est orientable, en Ex. 1 n'est pas orientable. Le poids dans le tableau inclut le moteur
- The fan in Ex. 4 without front support is revolvable, in Ex. 1 is not revolvable. The weight indicated in the table includes motor
- Der Ventilator in Aus. 4, ohne Vorderhalterung, ist drehbar; in Aus. 1 ist nicht drehbar.
- El ventilador en Ej. 4 sin soporte delantero es orientable, en Ej. 1 no es orientable. El peso en la tabla incluye el motor

TIPO - Type		PESO Weight Kg	PD ² Kgf x m ²	B	I	H	H1	H2	J	K	M	Q	R	Ø
VENTILATORE Fan	MOTORE Motor													
VAPE1000/N2R	225 M2	680	28	935	421	900*	900*	900	556	616	540	80	39	19
VAPE1000/N2R	250 M2	765	28	1043	501	900*	900*	900	604	690	600	60	39	19
VAPE1000/N2	250 M2	780	35	1043	501	900*	900*	900	604	690	600	60	39	19
VAPE1000/N2	280 S2	924	35	1046	591	900*	900*	900	690	750	697	60	46	21
VAPE1000/N/T		457	35			770	670	900						

pg. / s. 4.6



pg. / s. 4.5

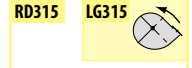
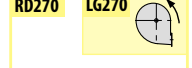
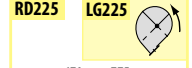
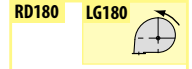
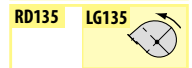
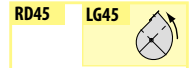

VAPE/N

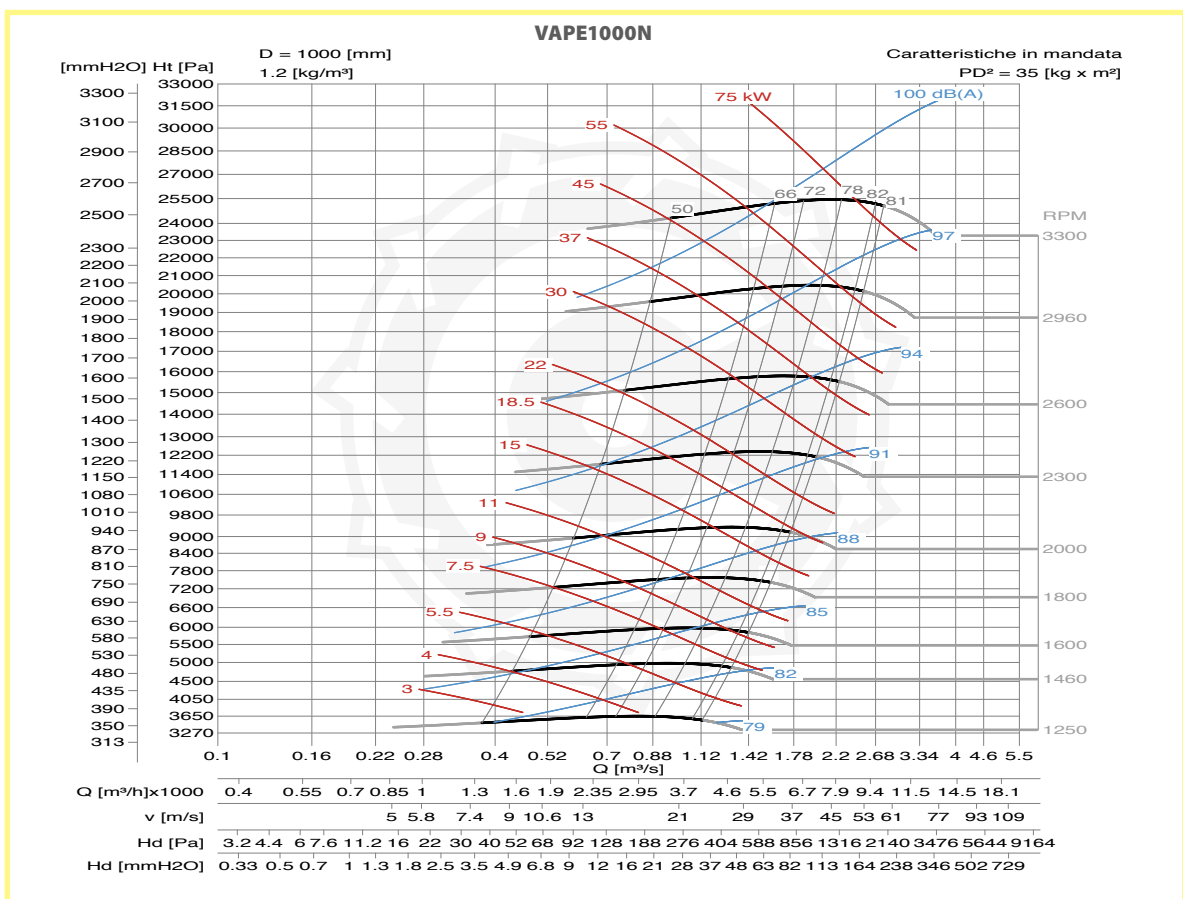

DIMENSIONI D'INGOMBRO E PESI/CURVE DI FUNZIONAMENTO

■ DIMENSIONS D'ENCOMBREMENT ET POIDS/COURBES DE FONCTIONNEMENT ■ OVERALL DIMENSIONS AND WEIGHT/WORKING CURVES
 ■ AUSMAßE UND GEWICHTE/FUNKTIONSKURVEN ■ DIMENSIONES QUE OCUPA Y PESOS/CURVAS DE FUNCIONAMIENTO

VAPE1120/N

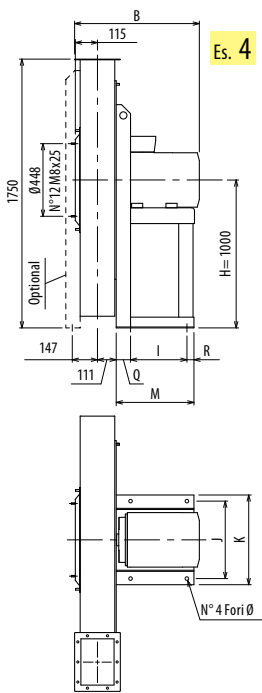

Es. 4

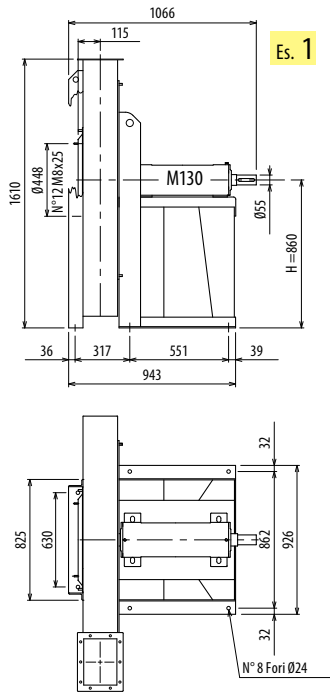

Es. 1

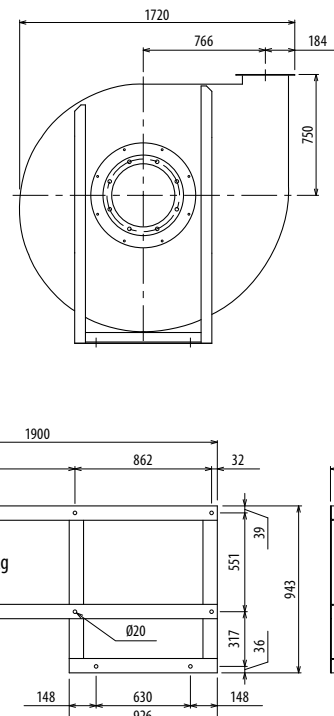

Il ventilatore in ES. 4 senza supporto anteriore è orientabile, in ES. 1 non è orientabile • Peso in tabella comprensivo di motore

- Le ventilateur en Ex. 4 sans support frontal est orientable, in Ex. 1 n'est pas orientable. ■ The fan in Ex. 4 without front support is revoluble, in Ex. 1 is not revoluble.
- Der Ventilator in Aus. 4, ohne Vorderhalterung, ist drehbar; in Aus. 1 ist nicht drehbar. ■ El ventilador en Ej. 4 sin soporte delantero es orientable, en Ej. 1 no es orientable.
- Das Gewicht in Tafel schließt den Motor ein. ■ El peso en la tabla incluye el motor

Ulteriori informazioni e quote:
 ■ Ulérieures informations et cotes:
 ■ Further information and sizes:
 ■ Weitere Infos und Größen:
 ■ Más informaciones y medidas:

TIPO - Type		PESO Weight	PD ²											
VENTILATORE Fan	MOTORE Motor	Kg	Kgf x m ²	B	I	H	H1	H2	J	K	M	Q	R	Ø
VAPE1120/N2R	280 M2	1085	47	1073	591	1000*	1000*	1000	690	750	697	60	46	21
VAPE1120/N2R	280 S2	1050	47	1073	591	1000*	1000*	1000	690	750	697	60	46	21
VAPE1120/N2	280 M2	1090	58	1073	591	1000*	1000*	1000	690	750	697	60	46	21
VAPE1120/N2	315 S2	1270	58	1285	675	1000*	1000*	1000	760	865	800	80	45	24
VAPE1120/N/T		481	58			860	750	1000						

pg./s. 4,6



pg./s. 4,5

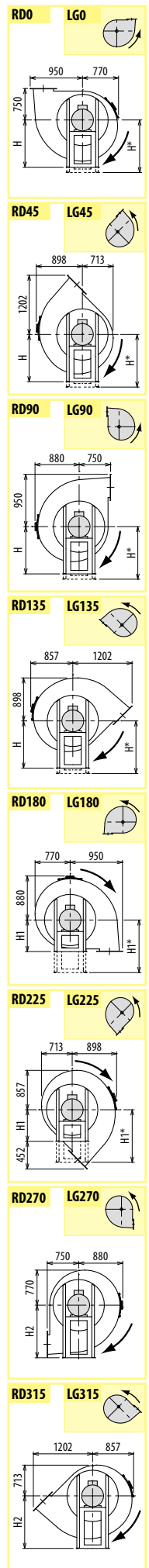

VAPE/N

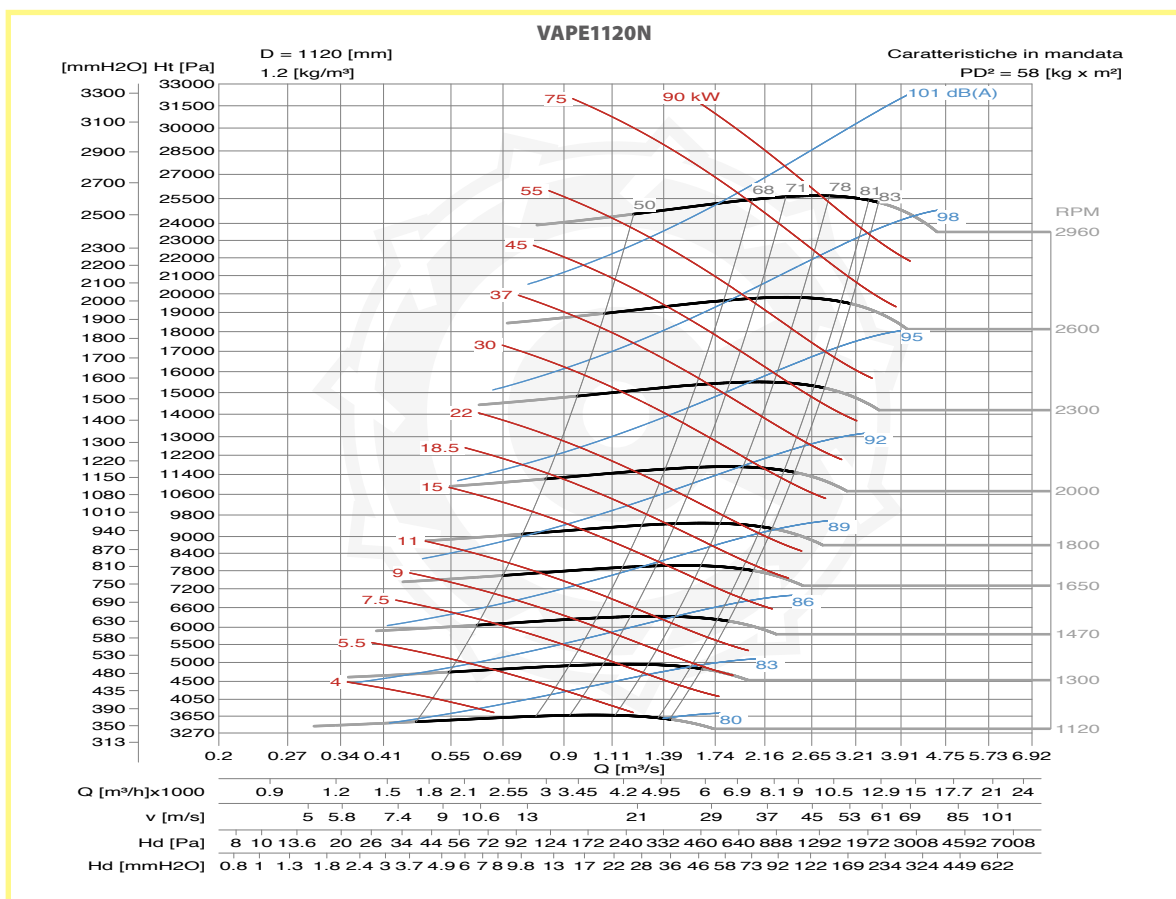

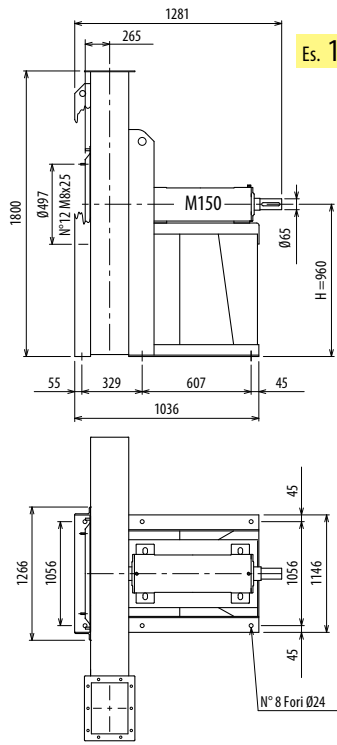

Es. 1

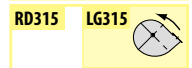
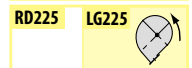
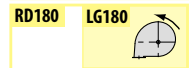
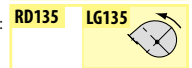
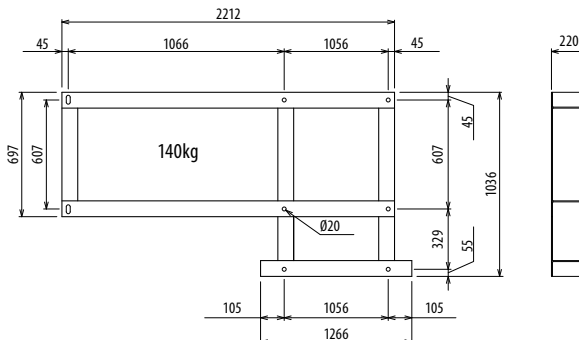
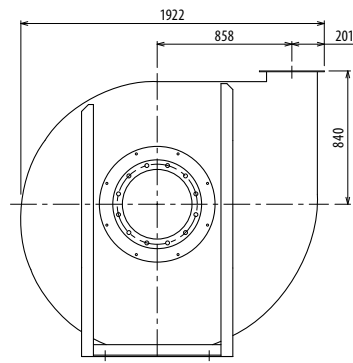

Il ventilatore non è orientabile

■ Le ventilateur n'est pas orientable

■ The fan is not revolvable

■ Der Ventilator ist nicht drehbar

■ El ventilador no es orientable

Ulteriori informazioni e quote:

■ Ulérieures informations et cotes:

■ Further information and sizes:

■ Weitere Infos und Größen:

■ Más informaciones y medidas:

TIPO - Type		PESO Weight	PD ²										
VENTILATORE Fan	MOTORE Motor	Kg	Kgf x m ²	B	I	H	H1	H2	H3	H4	M		
VAPE1250/N/T		1105	100			960	840	1120	960	1120		pg./s. 4,6	

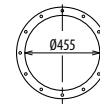

VAPE/N

VAPE1250N

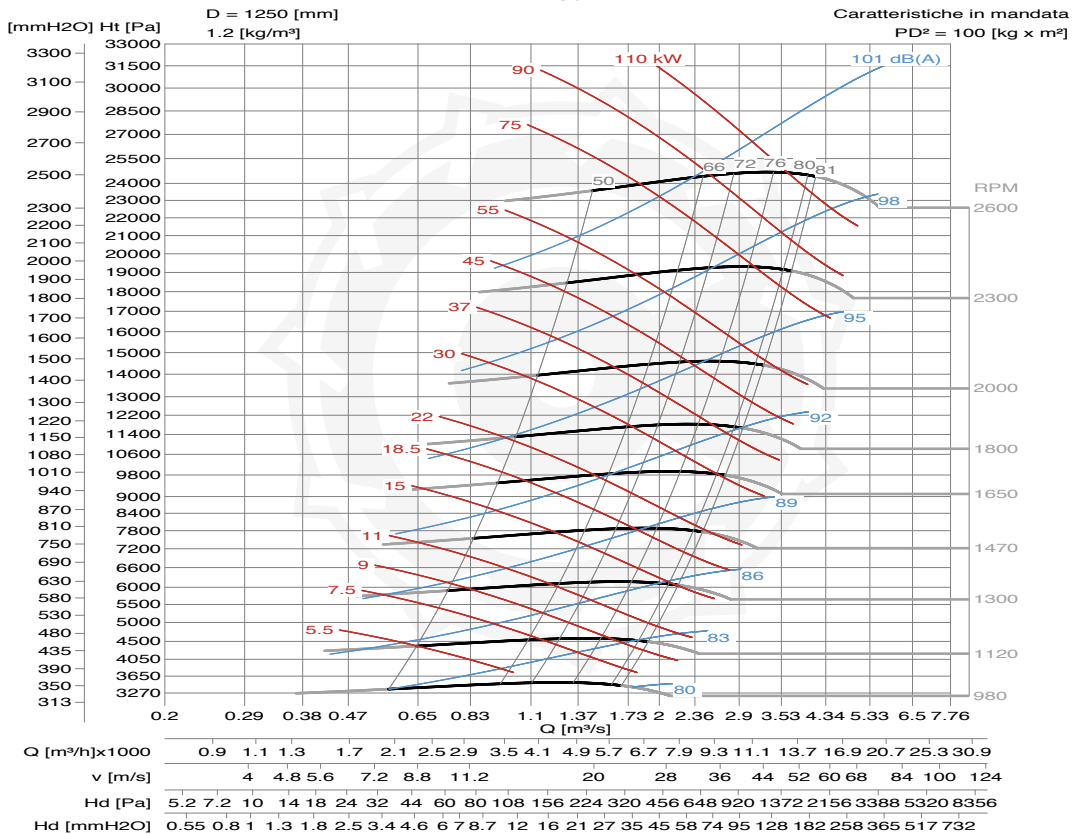

DIMENSIONI D'INGOMBRO E PESI/CURVE DI FUNZIONAMENTO

■ DIMENSIONS D'ENCOMBREMENT ET POIDS/COURBES DE FONCTIONNEMENT ■ OVERALL DIMENSIONS AND WEIGHT/WORKING CURVES
 ■ AUSMAßE UND GEWICHTE/FUNKTIONSKURVEN ■ DIMENSIONES QUE OCUPA Y PESOS/CURVAS DE FUNCIONAMIENTO

VAPE1400/N

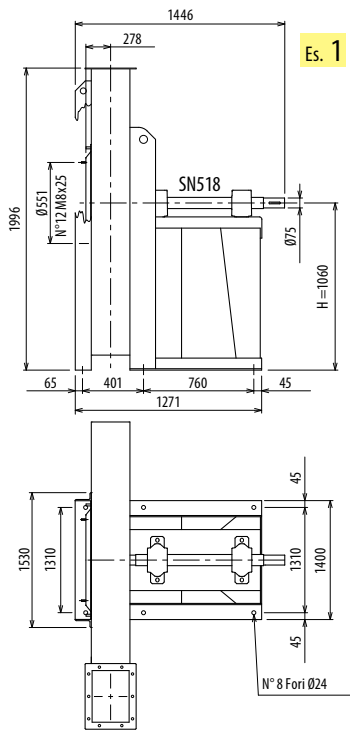

Es. 1

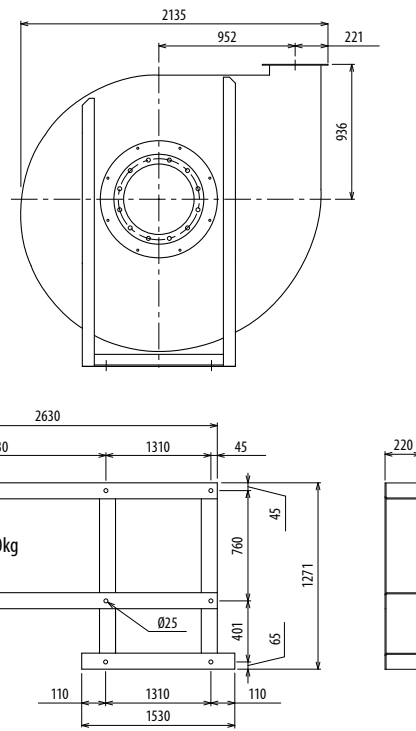

Il ventilatore non è orientabile • Peso in tabella comprensivo di motore

■ Le ventilateur n'est pas orientable ■ The fan is not revolvable
 Le poids dans le tableau inclut le moteur The weight indicated in the table includes motor

■ Der Ventilator ist nicht drehbar
 Das Gewicht im Tafel schließt den Motor ein

■ El ventilador no es orientable
 El peso en la tabla incluye el motor

Ulteriori informazioni e quote:

- Ulérieures informations et cotes:
- Further information and sizes:
- Weitere Infos und Größen:
- Más informaciones y medidas:

TIPO - Type		PESO Weight	PD ²												
VENTILATORE Fan	MOTORE Motor	Kg	Kgf x m ²	B	I	H	H1	H2	H3	H4	M				
VAPE1400/N/T		1200	170			1060	936	1200	1070	1200					

pg. / s. 4,6
 pg. / s. 4,5

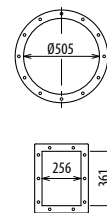

RD0 LG0

RD45 LG45

RD90 LG90

RD135 LG135

RD180 LG180

RD225 LG225

RD270 LG270

RD315 LG315

VAPE/N

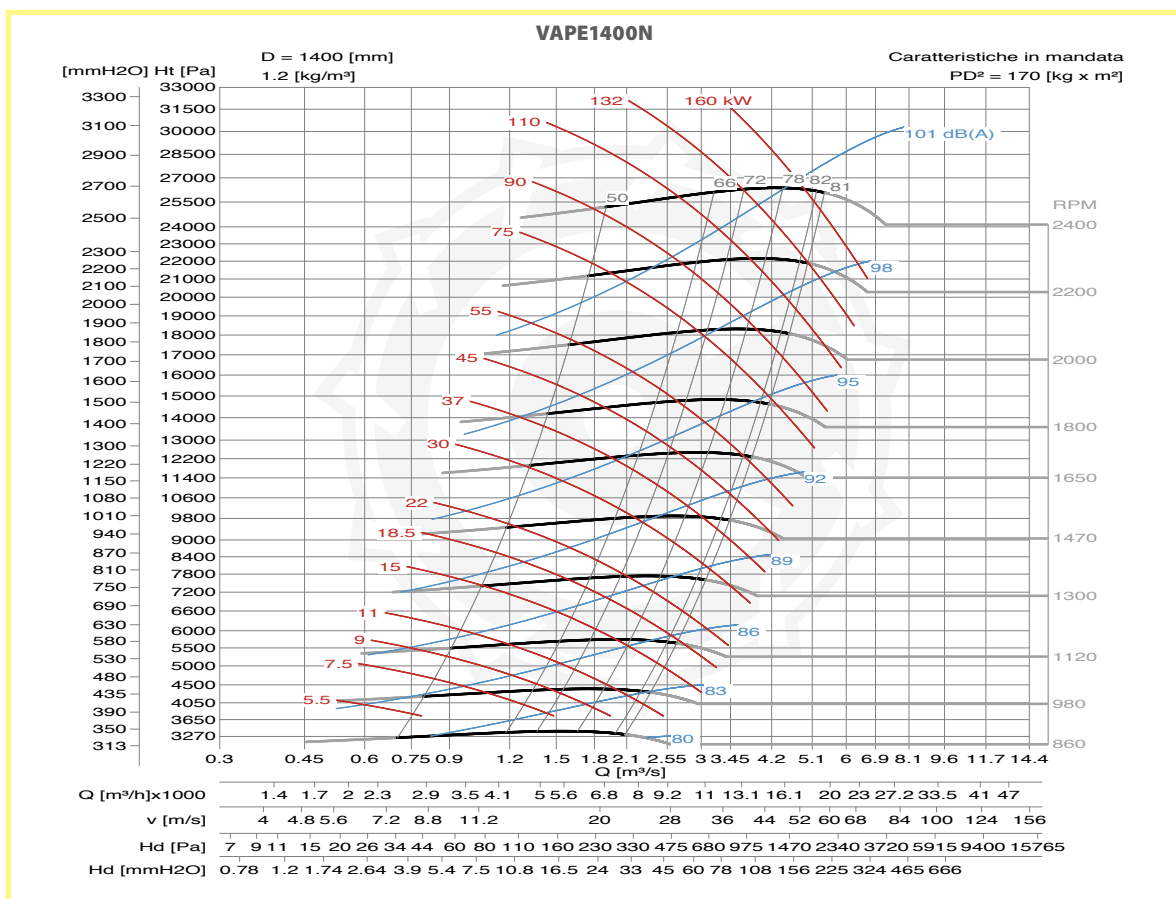

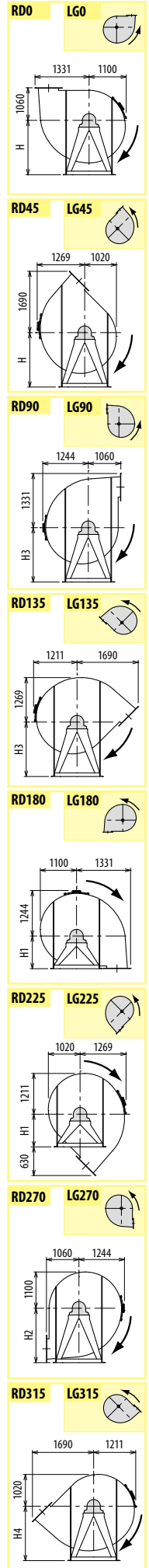
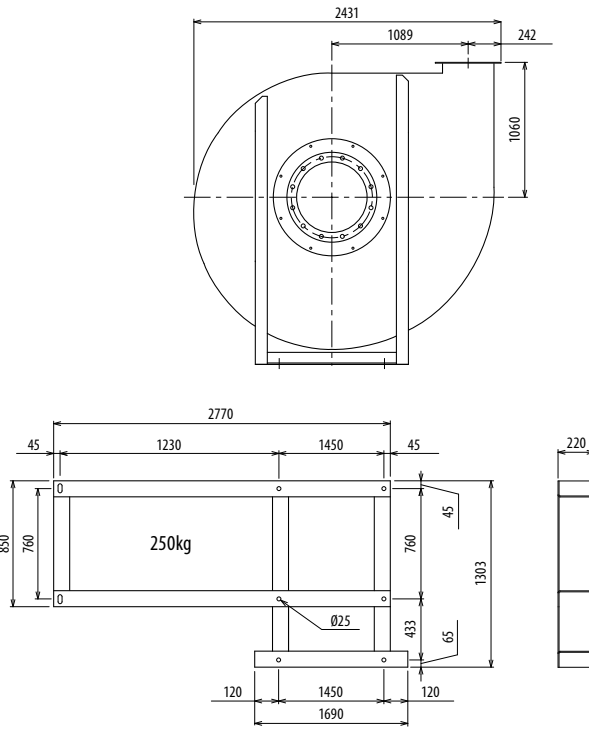
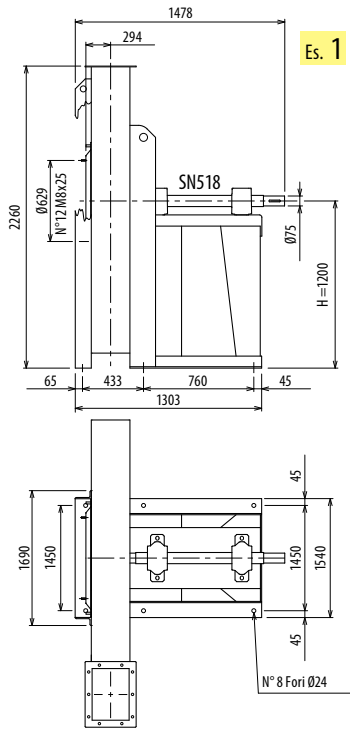

Il ventilatore non è orientabile • Peso in tabella comprensivo di motore

- Le ventilateur n'est pas orientable
- The fan is not revolvable
- Der Ventilator ist nicht drehbar
- El ventilador no es orientable
- Le poids dans le tableau inclut le moteur
- The weight indicated in the table includes motor
- Das Gewicht im Tafel schließt den Motor ein
- El peso en la tabla incluye el motor

Ulteriori informazioni e quote:

- Ulérieures informations et cotes:
- Further information and sizes:
- Weitere Infos und Größen:
- Más informaciones y medidas:

TIPO - Type		PESO Weight Kg	PD ² Kgf x m ²	B	I	H	H1	H2	H3	H4	M
VENTILATORE Fan	MOTORE Motor										
VAPE1600/N/T		1490	280			1200	1060	1400	1120	1400	

pg. / s. 4,6
pg. / s. 4,5

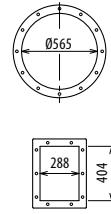

VAPE/N

