

SERIE 100

100 SERIES - SERIE 100

Rapporto di variazione 1:3

Variation ratio 1:3

Variationsverhältnis 1:3

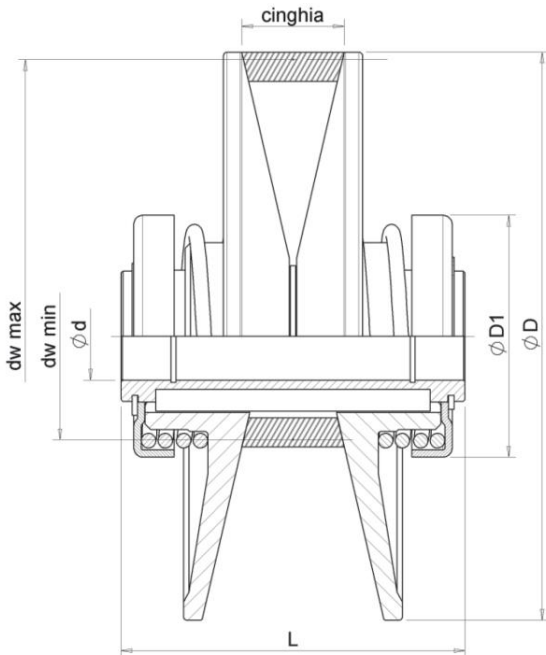

serie 100



TABELLA DIMENSIONALE (mm) - DIMENSIONS TABLE - GRÖSSENTABELLE

GRANDEZZA SIZE GRÖSSE	95	110	120	155	180	220
Potenza (Kw) - Power - Motorleistung ⁽¹⁾	0,37	0,55	0,75	1,5	3	4
Sezione cinghia - Belt - Reimen	13x6	17x5	22x8	28x8	28x8	37x10
ø d standard ⁽²⁾	14	14-19	14-19	19-24	24-28	28
ø d max ⁽²⁾	20	20	22	25	30	30
ø D	95	110	120	155	180	220
ø D ₁	58	58	58	66	85	85
dw min	40	38,5	48	50	58	61
dw max	92	107,5	116	151	176	215
L	65	72	72	94	110	125
Peso (kg) - Weight - Gewicht	1	1,4	1,6	2,5	4	5

⁽¹⁾ MOTORI A 4 POLI 1400/1' - 4 POLES MOTORS 1400/1' - MOTOREN BEI 4 POLIG 1400/1'

⁽²⁾ FORI - BORES - BOHRUNG: ISO H7

CAVE - KEYWAYS - NUT: UNI 6604/69 - DIN 6885/1-3

DATI NON IMPEGNATIVI - NOT BINDING DATA - UNVERBINDLICHE DATEN