

# COMPACT RT SCISSORS

# S2770/3370RT

DIMENSIONS	S2770RT	S3370RT
Max. working height	10.3m	12.1m
Max. platform height (A)	8.28m	10.1m
Platform size (stowed) (B)	2.74m x 1.65m	2.74m x 1.65m
Platform size (extended) (C)	4.0m x 1.65m	4.0m x 1.65m
Deck extension	1.2m	1.2m
Overall width (D)	1.77m	1.77m
Overall length (E)	3.36m	3.36m
Stowed height (F)	2.56m	2.70m
Min. height (guardrails folded)	1.75m	2.00m
Ground clearance	350mm	350mm

PERFORMANCE		
Platform capacity (SWL)	580kg	450kg
Max. drive height	8.28m	10.1m
Max. drive speed (stowed)	4.5km/h	4.5km/h
Max. drive speed (elevated)	0.9km/h	0.35km/h
Raise/lower time	26/30 sec	50/60 sec
Gradeability	35%	35%
Max. outrigger levelling, front to rear	6°	6°
Max. outrigger levelling, side to side	10°	10°
Inside turning radius	2.83m	2.83m
Outside turning radius	4.60m	4.60m
Tyres	27 x 10.5 - 15 poly filled loader lug	
Controls	proportional joystick	
Drive system	4 wheel drive	4 wheel drive

POWER	
Power source	Kubota D-902 water cooled diesel 22.5h

WEIGHT		
Gross weight	2,800kg	3,620kg

## TURNING RADIUS

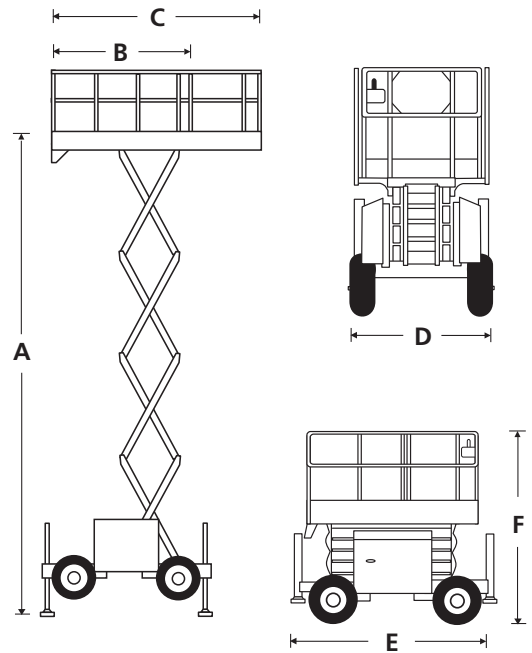
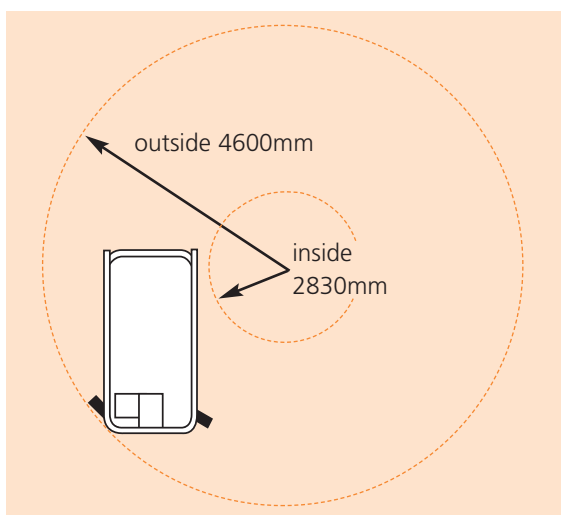

## STANDARD FEATURES

- 1.2m deck extension
- 4 wheel drive
- 4 hydraulic outriggers with automatic levelling
- Proportional joystick control
- Poly filled lug tyres
- Articulating axle
- Power line to platform (no sockets)
- Horn
- Drive motion alarm
- Lower warning alarm
- Fold-down guardrails
- CE approved

## OPTIONS

- Special paint colours
- Non marking tyres
- LPG power
- 3.5 KVA hydraulic generator

**snorkel**

Vigo Centre, Birtley Road,  
Washington, Tyne & Wear,  
NE38 9DA, U.K.

t: +44 (0) 845 1550 057

e: sales@snorkellifts.com

www.snorkellifts.com