

# Chariot INOX CR 80

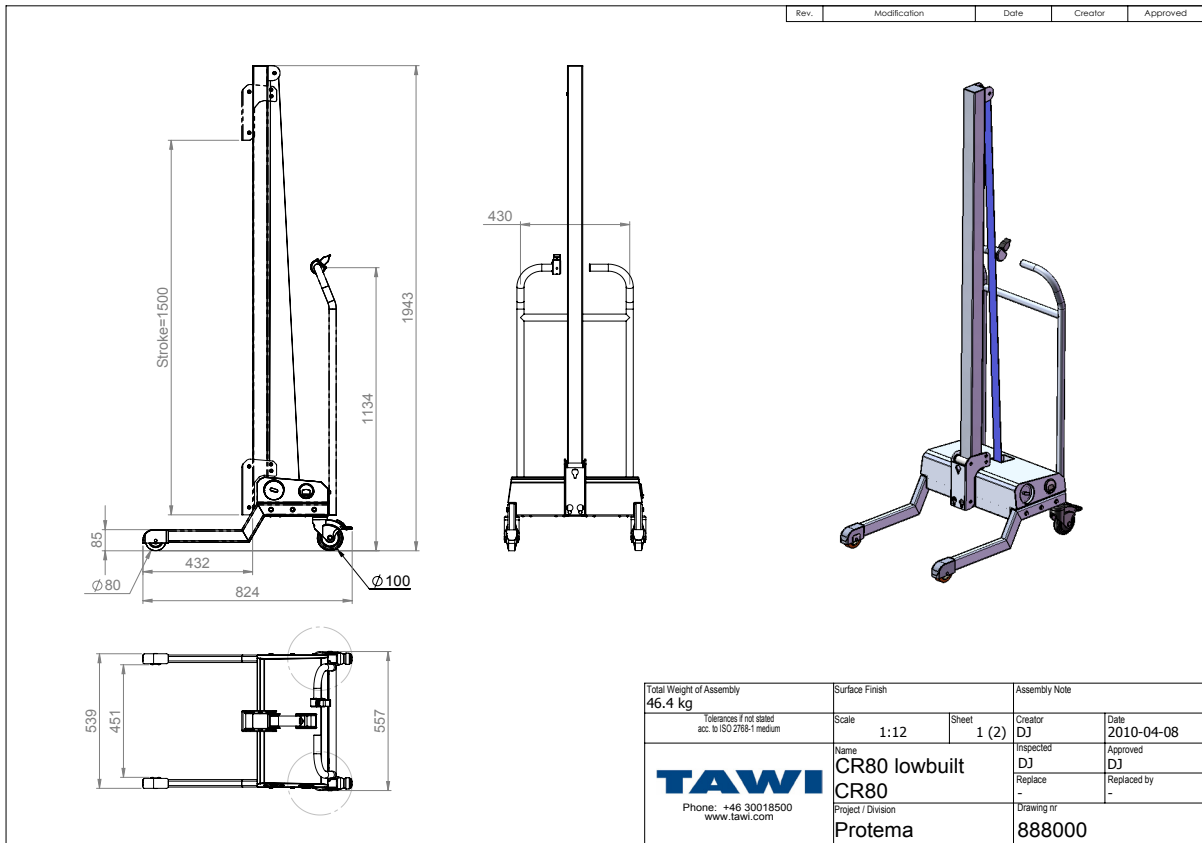

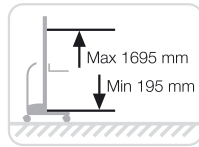

1. Frame 8830 for platform 8831A/8831B (410x400 mm). Including quick-coupling system.

Alt. 1

Alt. 2

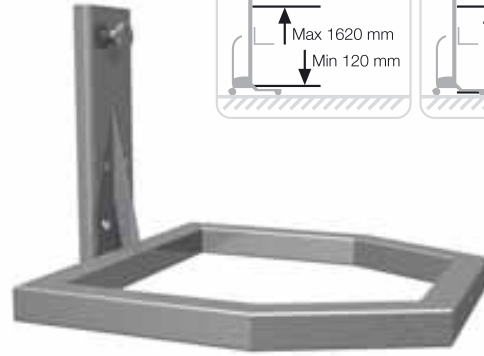
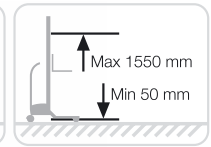
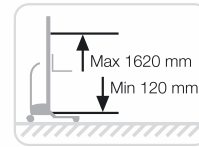

2. Frame 8832 for platform 8831C (410x400 mm). Including quick-coupling system.

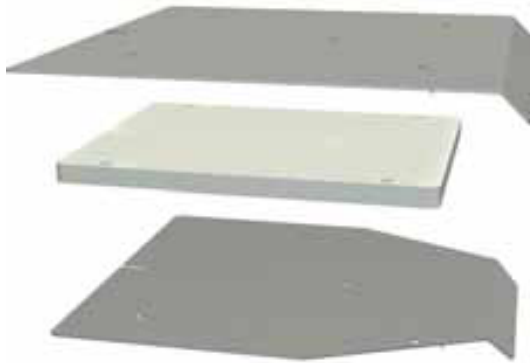

3. Top: Platform 8831A in stainless steel for frame 8830 (480x460 mm). Centre: Platform 8831B in HD polyethylene (delrin) for frame 8830 (480x430 mm). Below: Platform 8831C in stainless steel for frame 8832 (415x404 mm).

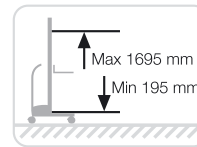

4. 8845, foldable platform with forks (548x435 mm). Including quick-coupling system.



5. V-block 8161A (stainless steel) and rotating plate 8162A (HD polyethylene) for rollhandling.

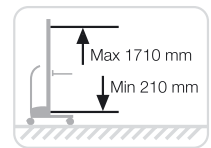

6. Bom 8840 for rollhandling (500xØ63,5 mm). Including quick-coupling system.