

MDM6861 Differential Pressure Transmitter



Features

- NB-IoT / 4G network for application
- Integrated high-energy lithium battery, with service life over 2 years
- Data application in PC and mobile terminals, device data query
- Based on GIS managing system, device status prompt
- Support remote setting for data collecting frequency, data transferring frequency, etc.
- Indicator light alert for device state/ abnormal conditions
- Opened database and interface protocol, and available interface parsing file
- Safely applied in explosive hazardous area

Introduction

MDM6861 is a wireless differential pressure transmitter with low power consumption and wireless communication function. It can be equipped with NB-IoT/4G network. It reports the data according to the set interval and sends alarms to users. Customers can configure the device and inquire for data remotely by Web page. All the upload and download data will be stored into the database automatically for later query. It is more intuitive, accurate and efficient through PC or mobile terminals access internet to acquire and analyze data as well as forming with report and data curve. The transmitter can detect the real-time data of many monitoring points in a large area such as petroleum, chemical industry, electric power, hydrology and other fields requiring unattended and remote monitoring.

Specification

- Differential Pressure Range: 0kPa~35kPa...3.5MPa
- Accuracy: $\pm 1.0\%$ FS
- Static Pressure Range: 0kPa~35kPa...20MPa
- Overpressure: 1.5 times FS
- Long Term Stability: $\pm 0.5\%$ FS/Year
- Pressure Type: Absolute/Sealed Gauge
- Power Supply: 3.6V@38Ah Lithium Battery/9V~36V DC
- SIM Card: Nano SIM(12mm×9mm)
- Display: LCD display
- Keyboard: Panel key triggered
- Setting: In site/Remote control
- Weight: ≥ 1.5 kgs
- Communication Mode: NB-IoT/4G
- Communication Protocol: MQTT
- Consumption: Average current at sending status ≤ 100 mA@3.6V DC, at sleep mode ≤ 25 uA@3.6V DC

Environment Conditions

- Operation Temperature: -20℃ ~70℃
- Storage Temperature: -40℃ ~85℃
- Relative Humidity: 0%~95%
- Protection: IP65
- Explosive-proof: Exd IIC T6 Gb

Outline Construction (Unit: mm)

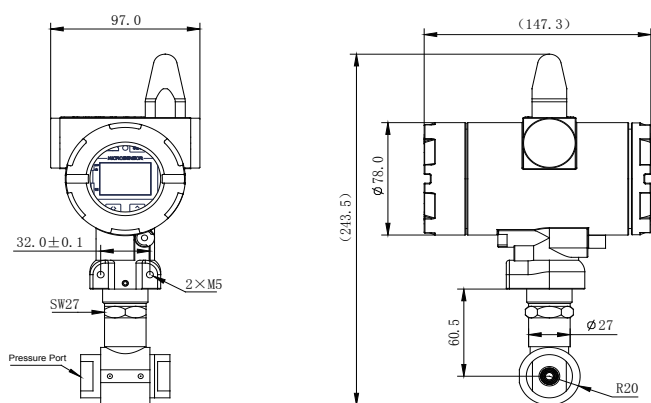

Fig.1 MDM6861 Wireless Differential Pressure

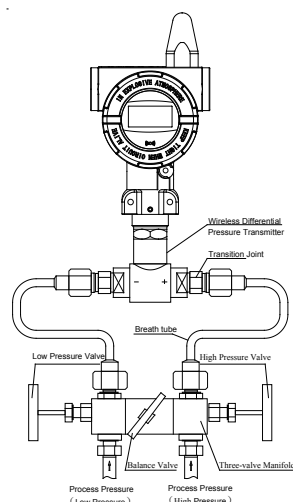

Fig.2 Installation of MDM6861 Wireless Differential Pressure Transmitter

Data Transmission

Communication Mode		Standard/Band	Transmission Distance
Multi-Bands	China	TDD-LTE B38/B39/B40/B41 FDD-LTE B1/B3/B8 TD-SCDMA B34/B39 WCDMA B1 CDMA 1X/EVDO BC0 GSM/GPRS/EDGE B3/B8	Global Bands
	Europe / Korea / EMEA/ Thailand / India	FDD-LTE B1/B3/B5/B7/B8/B20 WCDMA B1/B5/B8 GSM/GPRS/EDGE B3/B8	
	North America	FDD-LTE B2/B4/B12 WCDMA B2/B5	
	South America / Australia/ New Zealand / Taiwan, China	TDD-LTE B40 FDD-LTE B1/B2/B3/B4/B5/B7/B8/B28 WCDMA B1/B2/B5/B8 GSM/GPRS/EDGE B2/B3/B5/B8	
	NB-IoT	B3/B5/B8	

Order Guide

MDM6861		Wireless Differential Pressure Transmitter						
	Range	Measuring Range						
	[0~X]kPa/MPa	Differential Pressure: X represents the actual range(0kPa~35kPa...3.5MPa)						
	[0~X]kPa/MPa	Static Pressure: X represents the actual range(0kPa~35kPa...20MPa) (Static Pressure does not output.)						
		Code	Communication Mode					
		GC	4G Multi-Bands in China mainland					
		GE	4G Multi-Bands in EMEA/Korea/Thailand/India					
		GA	4G Multi-Bands in North America					
		GS	4G Multi-Bands in South America/Australia/New Zealand/Taiwan, China					
		GN	NB-IoT					
		GD	4G, 2G and NB-IoT, three-in-one					
		Code	Power Supply					
		N	Without Battery					
		E	Disposable Lithium-thionyl Chloride(Li-SOCI2) Battery(3.6V/38Ah)					
		D	DC Power Supply(9V~36V DC)					
		Code	Antenna Type					
		A1	Integrated Antenna(Recommended)					
		A2	External Sucker Antenna(Length=1m)					
		Code	SIM Card					
		S2	Self-owned SIM card (Data Flow Service Required)					
		Code	Software Service Type					
		M	Micro Sensor Big Data Platform					
		C	Customer Self-built Platform (Note on Docking Mode)					
		Code	Others					
		C1	M20×1.5 Male					
		C2	G1/4 Male					
		C3	G1/2 Male					
		C4	G1/4 Female					
		W	Separated Type Mounting Bracket					
		d	Explosion Proof Exd II C T6 Gb					
MDM6861	[0~150]kPa	G2	E	A1	S1	M	C4	The whole spec.

Introduction of Explosion Proof Exd IIC T6 Gb

Model: Intelligent Wireless Pressure Transmitter

Code: M 1 M6861- 2 - 3 - 4 - 5

Explosion Proof Rate: Exd IIC T6 Gb

Technical File: Q/MS J02.067-2019

Note:

1. Rated Voltage: 9~36V DC or 3.6V battery supply.
2. Code meaning:

①: P-Pressure, T-Temperature, D-Differential Pressure;

②: Pressure Range;

③: Communication Mode;

④: Power supply;

⑤: Antenna.

3. Housing Protection Class: IP65.

4. Environment Temperature: $-20^{\circ}\text{C} \leq \text{Temp.} \leq 70^{\circ}\text{C}$.

Order Notes:

1. In order to ensure the safe and reliable operation of the transmitter, it is recommended to install a three-valve manifold between the measured point and the transmitter. Please ensure that the measured medium is slowly and evenly applied to the positive and negative pressure chambers of the differential pressure transmitter.
2. The signs “+” and “-” are used to mark the high and low pressure. When the product is used, the pressure that is input to high pressure part should not be lower than that for low pressure part.
3. When installing, it is recommended to remain level of the pressure interfaces at both ends, so that the impact of the installation position on the product is minimized.
4. When selecting the model, please note that the static pressure of the measured pressure point should not be beyond 20 MPa, and the overpressure of the positive and negative pressure chambers of the transmitter should not exceed the specific value of the product.
5. If users need docking platform, please refer to the following (such as: I1);

Classification:

I1: No docking, Micro Sensor platform is selected;

I2: Retrieves data through the API interface;

I3: Open limited access to the database and users can retrieve data themselves;

I4: Force control configuration docking;

I5: Provide communication protocol and users will write the analysis program to complete the docking;

I6: Set up the resolution server, deploy the resolver, and deploy the default database (php+apache+Mysql);

I7: Set up the resolution server, deploy the specified database resolution program (sqlserver, oracle, postgresql...);

I8: Deploy the parsing SDK to parse the data according to the data format specified by the customer;

I9: Users customize docking method; order note is required.

6. For special requirements, please contact us and note in the order.