

DRIVE THE CHANGE



BR.2018.04.0085.03.04

CORMIDI

C85
MINI TRACK DUMPER



DRIVE THE CHANGE

EFFICACITÉ MAXIMALE



Effacité maximale De nombreuses heures de contrôle et d'optimisation de précision de tous les composants ont fait de la C85 la machine la plus performante et la plus fiable de sa catégorie

CHÂSSIS PORTEUR



Le chariot-porteur conçu dans les moindres détails pour la C85 est le résultat de l'expérience de l'équipe de développement de la société Cormidi, pour un chariot-porteur incomparable.

STUPEFIANT



Le CDL, centre de style de Cormidi a créé une machine aux lignes douces et sinueuses, agréable à regarder, mais en même temps solide, concrète et ergonomique.

CORMIDI

C85
MINI TRACK DUMPER



DRIVE THE CHANGE

POINTS FORTS



DESIGN ERGONOMIQUE

Le design du C85 contient un mélange de beauté compacte et construction de solide.



LEVIERS

Le lieu de promenade à taille humaine pour une conduite agréable et relaxante.



BENNE AUTOCHARGEUR

Benne avec double fonction: auto-chargeur plus décharge avant.



CONTROL VISUEL DU NIVEAU

Niveau gas-oil visible.



TOUT DANS L'ORDRE

Le capot a une excellente disposition des composants; tous pour le bénéfice d'un accès facile aux outils.



ROULEAUX

Graisser les rouleaux est facile, rapide et pratique, sans démonter quoi que ce soit pour profiter pleinement de l'entretien.



BOUCHON DE RÉSERVOIR

(version diesel) avec clé.



ACCESSOIRES DE FIXATION RAPIDE

Les bouteilles sont protégées par des enveloppes de protection



GRAND RADIATEUR (VERSION 14 HP)

Le système de refroidissement eau / huile permet de travailler dans des conditions de température extrêmes.

CORMIDI

C85

MINI TRACK DUMPER



DRIVE THE CHANGE

POINTS FORTS



TÉLÉCOMMANDE

La machine peut être radiocommandée pour les travaux dangereux.



REFROIDISSEMENT

Système de refroidissement vraiment efficace aider le travail dans toutes les conditions.



ACCÉLÉRATEUR

Accélérateur sans entretien.



SORTIE HYDRAULIQUE AUSILIAIRE

L'accessoire de connexion qui nécessite plus d'hydraulique n'a jamais été aussi facile.



PANNEAU DE CONTRÔLE

Un buzzer alertera l'opérateur en cas de nécessité et l'affichage permet toujours une lecture facile du travail heures.



FREIN

Frein à main mécanique.



POINTS D'ANCRAGE

Points d'ancrage pour l'arrimage en transport et pour le levage de la machine.



ROULEAUX

Le système de rouleaux guides pendulaires utilisé depuis plus de 20 ans par CORMIDI est la garantie d'une grande stabilité et d'une longue durée de vie des chenilles



PLATEFORME OPÉRATEUR

Plateforme opérateur avec un système D'amortissement des vibrations, la plateforme est également repliable et permet d'utiliser le dumper dans des zones étroites et dans des pentes raides.

DUMPER (RI)

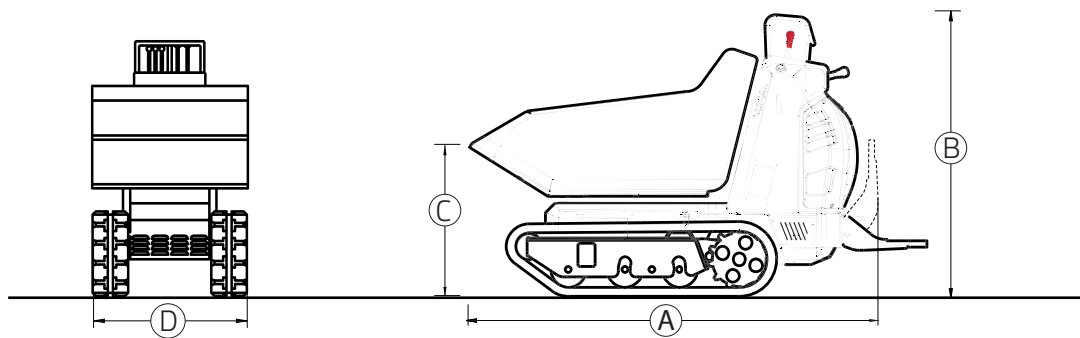

	mm	inch.
A	1926	A 75.8
B	1336	B 52.6
C	739	C 29.1
D	810	D 31.9

	C10.85	C13.85	C14.85
CAPACITE OPERATIONNELLE	800 kg 1764 Lb	800 kg 1764 Lb	800 kg 1764 Lb
POIDS TOTAL	566 kg 1248 Lb	541 kg 1193 Lb	588 kg 1296 Lb
A RAS BORD	0,28 m ³ 0.33 yd ³	0,28 m ³ 0.33 yd ³	0,28 m ³ 0.33 yd ³
A PLEINE CAPACITE SAE	0,36 m ³ 0.45 yd ³	0,36 m ³ 0.45 yd ³	0,36 m ³ 0.45 yd ³

CORMIDI

CBS

MINI TRACK DUMPER



DRIVE THE CHANGE

AGRI (RIA)

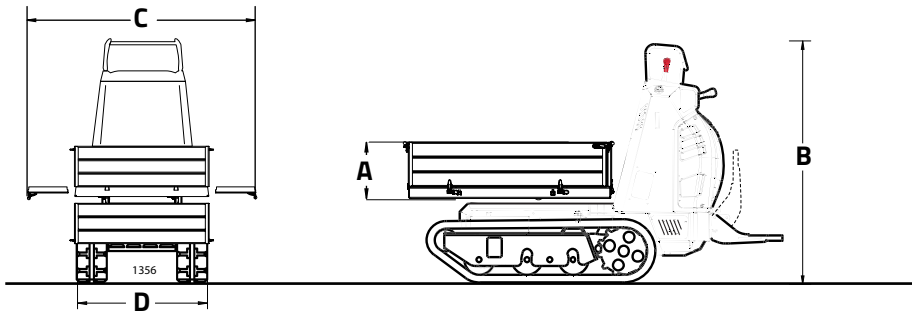
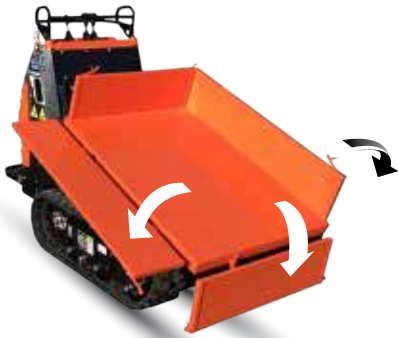

	mm	inch.
A	305	12.0
B	1336	52.6
C	1356	53.4
D	810	31.9

	C10.85	C13.85	C14.85
CAPACITE OPERATIONNELLE	800 kg 1764 Lb	800 kg 1764 Lb	800 kg 1764 Lb
POIDS TOTAL	-kg -Lb	-kg -Lb	-kg -Lb
A RAS BORD	0,19 m ³ 0,25 yd ³	0,19 m ³ 0,25 yd ³	0,19 m ³ 0,25 yd ³
A PLEINE CAPACITE SAE	0,31 m ³ 0,41 yd ³	0,31 m ³ 0,41 yd ³	0,31 m ³ 0,41 yd ³

CORMIDI

CBS

MINI TRACK DUMPER



DRIVE THE CHANGE

DUMPER (RI-Poly)

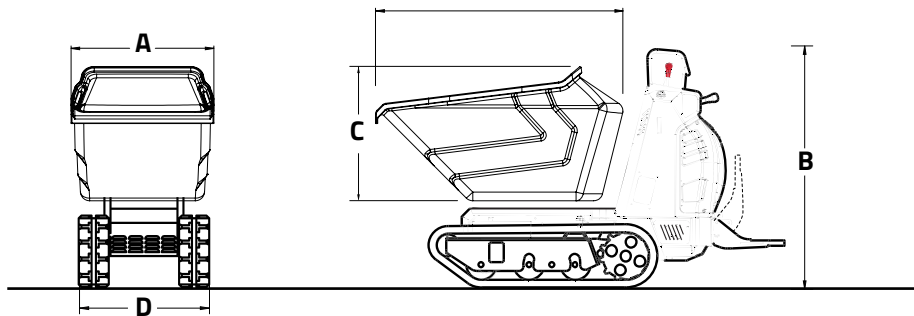

	mm	inch.
A	777	28.8
B	1336	52.6
C	730	29.1
D	810	31.9
F	1347	53.0

	C10.85	C13.85	C14.85
CAPACITE OPERATIONNELLE	800 kg 1764 Lb	800 kg 1764 Lb	800 kg 1764 Lb
POIDS TOTAL	-kg -Lb	-kg -Lb	-kg -Lb
A RAS BORD	0,39 m ³ 0.51 yd ³	0,39 m ³ 0.51 yd ³	0,39 m ³ 0.51 yd ³
A PLEINE CAPACITE SAE	0,53 m ³ 0.69 yd ³	0,53 m ³ 0.69 yd ³	0,53 m ³ 0.69 yd ³

CORMIDI

CBS

MINI TRACK DUMPER



DRIVE THE CHANGE

DUMPER (RIX-Poly)

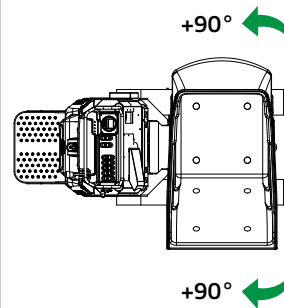
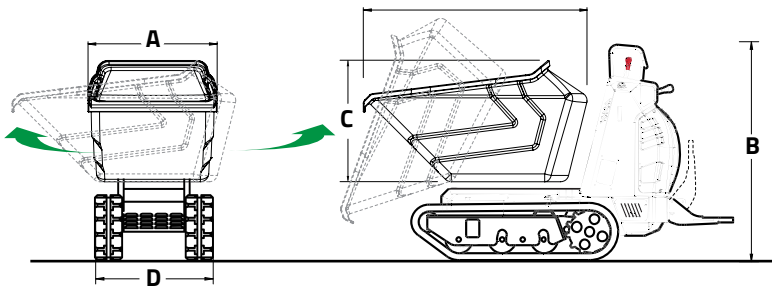

	mm	inch.
A	777	28.8
B	1336	52.6
C	730	29.1
D	810	31.9
F	1347	53.0

	C10.85	C13.85	C14.85
CAPACITE OPERATIONNELLE	800 kg 1764 Lb	800 kg 1764 Lb	800 kg 1764 Lb
POIDS TOTAL	-kg -Lb	-kg -Lb	-kg -Lb
A RAS BORD	0,39 m ³ 0.51 yd ³	0,39 m ³ 0.51 yd ³	0,39 m ³ 0.51 yd ³
A PLEINE CAPACITE SAE	0,53 m ³ 0.69 yd ³	0,53 m ³ 0.69 yd ³	0,53 m ³ 0.69 yd ³

CORMIDI

CBS

MINI TRACK DUMPER



DRIVE THE CHANGE

AUTOCHARGEUR (AC-ACW)

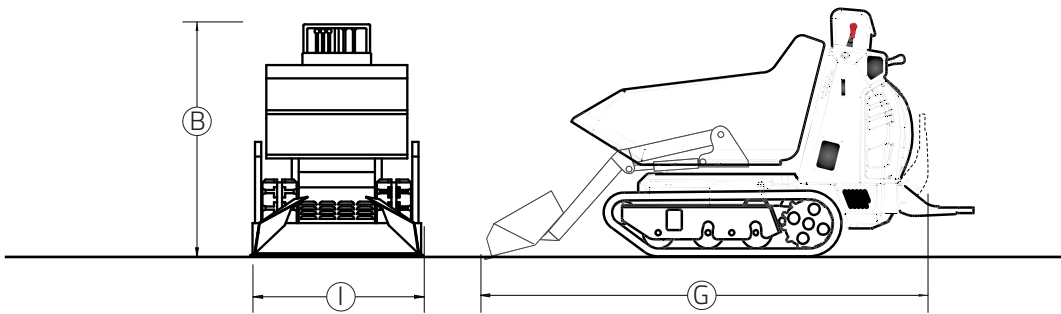

	mm	inch.
B	1336	B 52.6
G	2595	G 102.2
I	835	I 32.9
H	1500	H 59.1

	C10.85	C13.85	C14.85
CAPACITE OPERATIONNELLE	800 kg 1764 Lb	800 kg 1764 Lb	800 kg 1764 Lb
POIDS TOTAL	662 kg 1460 Lb	637 kg 1404 Lb	684 kg 1508 Lb
A RAS BORD	0,25 m ³ 0.33 yd ³	0,25 m ³ 0.33 yd ³	0,25 m ³ 0.33 yd ³
A PLEINE CAPACITE SAE	0,34 m ³ 0.45 yd ³	0,34 m ³ 0.45 yd ³	0,34 m ³ 0.45 yd ³

CORMIDI

CBS

MINI TRACK DUMPER



DRIVE THE CHANGE

HI-TIP (HI)

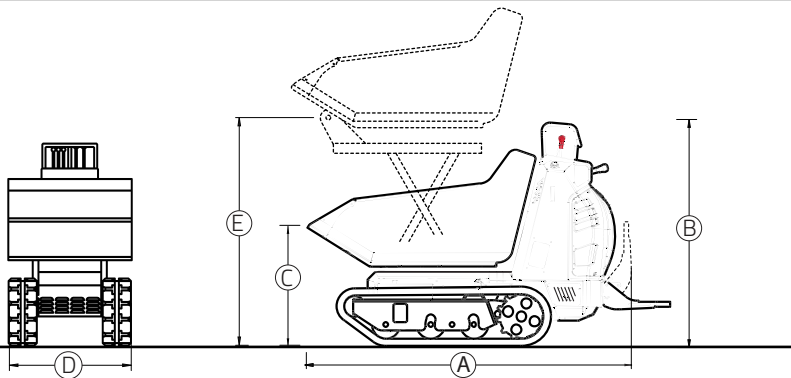

	mm	inch.
A	1926	A 75.8
B	1336	B 52.6
C	739	C 29.1
D	810	D 31.9
E	1500	E 59.1

	C10.85	C13.85	C14.85
CAPACITE OPERATIONNELLE	800 kg 1764 Lb	800 kg 1764 Lb	800 kg 1764 Lb
POIDS TOTAL	668 kg 1472.7 Lb	643 kg 1418 Lb	690 kg 1521 Lb
A RAS BORD	0,28 m ³ 0.33 yd ³	0,28 m ³ 0.33 yd ³	0,28 m ³ 0.33 yd ³
A PLEINE CAPACITE SAE	0,36 m ³ 0.45 yd ³	0,36 m ³ 0.45 yd ³	0,36 m ³ 0.45 yd ³

CORMIDI

CBS

MINI TRACK DUMPER



DRIVE THE CHANGE

HI-TIP ET AUTOCHARGEUR (HIAC-HIACW)

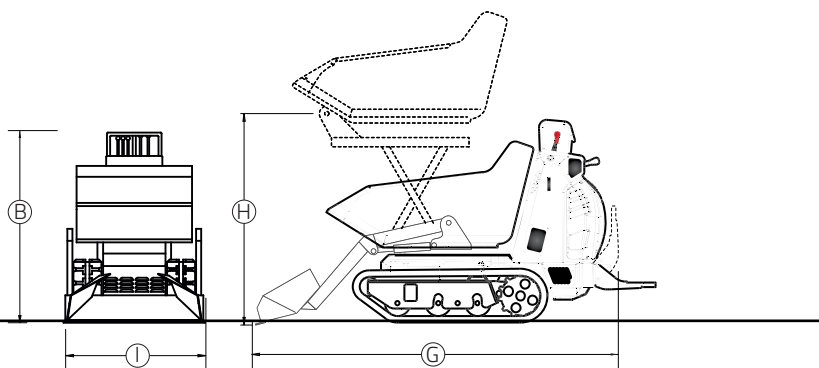

	mm	inch.
B	1336	B 52.6
G	2595	G 102.2
I	835	I 32.9
H	1500	H 59.1

	C10.85	C13.85	C14.85
CAPACITE OPERATIONNELLE	800 kg 1764 Lb	800 kg 1764 Lb	800 kg 1764 Lb
POIDS TOTAL	765 kg 1687 Lb	740 kg 1631 Lb	787 kg 1735 Lb
A RAS BORD	0,25 m ³ 0.33 yd ³	0,25 m ³ 0.33 yd ³	0,25 m ³ 0.33 yd ³
A PLEINE CAPACITE SAE	0,34 m ³ 0.45 yd ³	0,34 m ³ 0.45 yd ³	0,34 m ³ 0.45 yd ³

CORMIDI

CBS
MINI TRACK DUMPER



DRIVE THE CHANGE

BETONNIERE (AC)

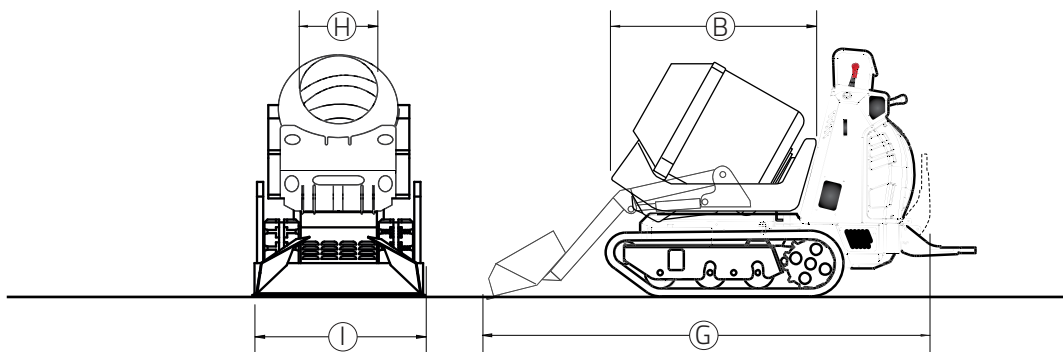

	mm	inch.
B	1125	B 44.3
G	2595	G 102.2
I	835	I 32.9
H	425	H 16.7

	C10.85	C13.85	C14.85
CAPACITE OPERATIONNELLE	800 kg 1764 Lb	800 kg 1764 Lb	800 kg 1764 Lb
POIDS TOTAL			
CAPACITÉ BRUTE	240 L 63.4 gal	240 L 63.4 gal	240 L 63.4 gal
CAPACITÉ NETTE	130 L 34.3 gal	130 L 34.3 gal	130 L 34.3 gal

CORMIDI

CBS

MINI TRACK DUMPER



DRIVE THE CHANGE

MINI CHARGEUR (ML)

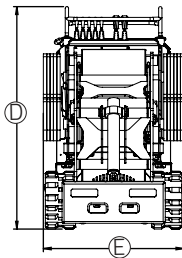
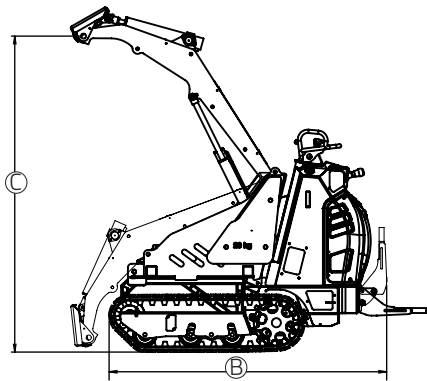
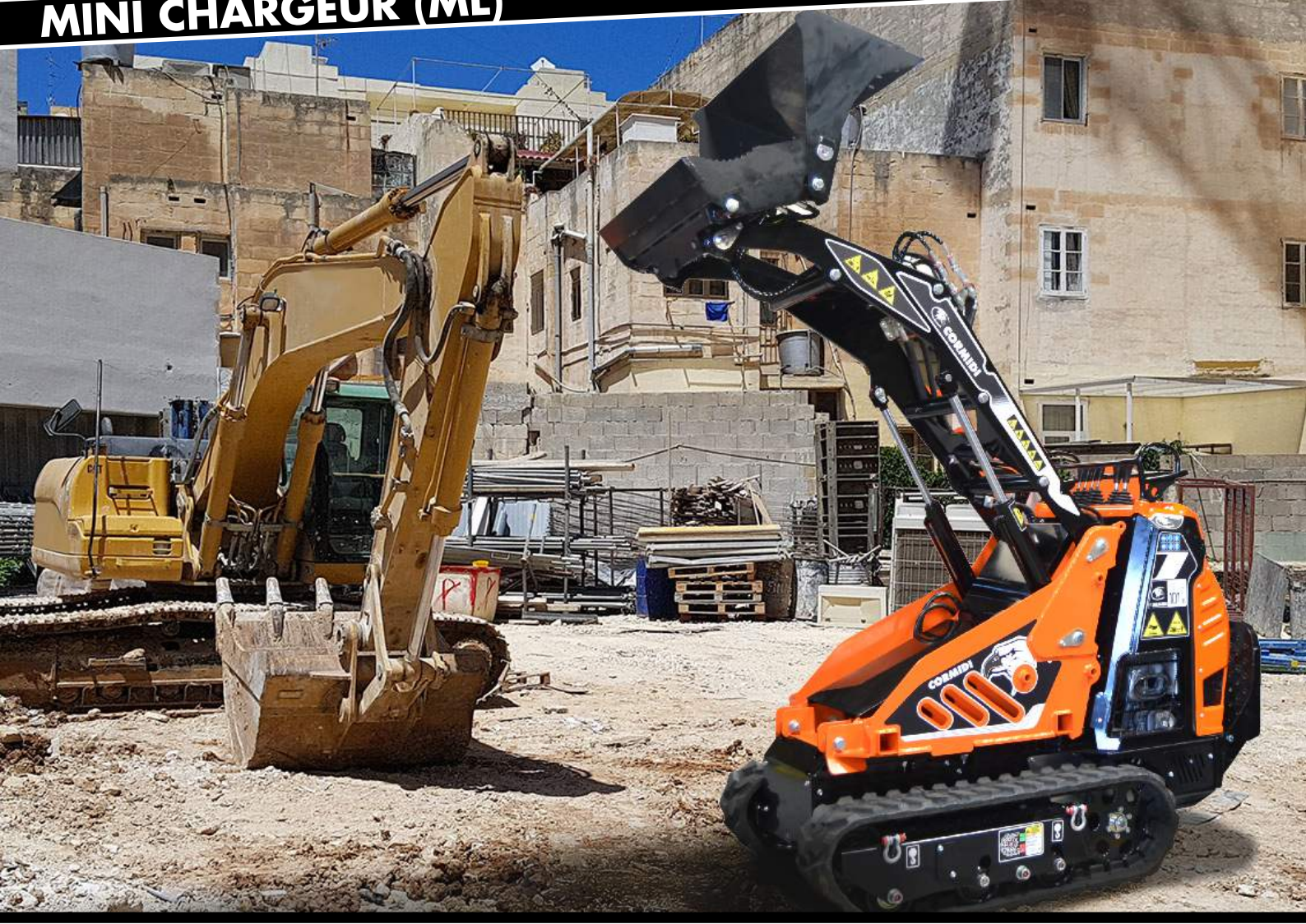

	mm	inch.
B	1654	B 65.1
C	1884	C 74.2
D	1326	D 52.2
E	837	E 33.0

	C10.85	C13.85	C14.85
poids total		775kg 1709 Lb	821 kg 1810 Lb
TIPPING CAPACITY			
WITHOUT COUNTERWEIGHT	461 kg 1.016 Lb	GROUND PRESSURE 0,341 kg/cm ² 4.84 psi	
WITH COUNTERWEIGHT 120 KG	643 kg 1418 Lb		

CORMIDI

CBS

MINI TRACK DUMPER



DRIVE THE CHANGE

DONNÉES TECHNIQUES

		METRIC	U.S.	13.85	10.85	14.85
MOTEUR						
Essence	Honda Gx 390 13 hp			●		
Diesel	Yanmar LN 100 AE 10 hp				●	
Diesel	Kubota Z 482 14 hp					●
Électrique						
TRANSMISSION						
Type	hydrostatique			●	●	●
Pompe hydraulique	2 transmissions hydrostatiques en circuit fermé à maintien de couple.			●	●	●
CHÂSSIS						
Largeur de chenilles	180 mm	(7.1 in)				
Roulements à rouleaux	Oui			●	●	●
SYSTÈME HYDRAULIQUE DE TRAVAIL						
Pompe hydraulique	Pompe à engrenages					
Debit Standard 1x15,2 l/min (1x4.0 gpm)	1x15,2 l/min	(1x4.0 gpm)	●			
	1x13,4 l/min	(1x3.5 gpm)		●	●	
Debit Hi-Flow	1x20,8 l/min	(1x5.5 gpm)	●			
	1x18,5 l/min	(1x4.8 gpm)		●	●	
Super Hi-Flow	1x25,6 l/min	(1x6.7 gpm)				●
Pression maximale	150 bar	(2180 psi)	●	●	●	
PERFORMANCES ET DIMENSIONS						
Vitesse de déplacement max	(5 Km/h)	(3.1 mph)	●			
	(6 Km/h)	(3.7 mph)		●		
Capacité opérationnelle	800 kg	(1762 LB)	●	●	●	
Poids	560 to/a 690 kg	(1235 to/a 1521)	●			
	540 to/a 750 kg	(1191 to/a 1654)		●		
Capacité du caisson	0.28 m ³	(0.37 yd ³)	●	●	●	
	0.45 m ³	(0.59 yd ³)				●
Frein de stationnement	Oui			●	●	●

ACCESSORIES

radio



Fourches

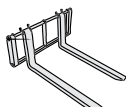

Lame
chasse-neige



Excavatrice



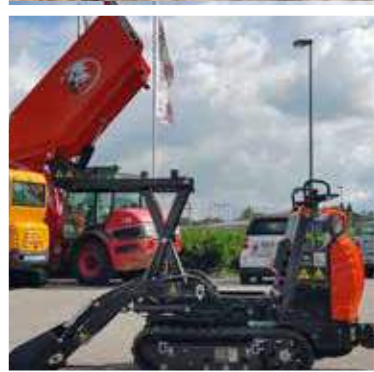



DRIVE THE CHANGE

Les machines et accessoires de ce document ne sont pas contractuels, CORMIDI peut procéder sans préavis à tous changements s'il le veut. De ce fait les données et les photos du document sont à seulement à titre indicatif.

 Via Fonte, 342 Roccadaspide
(SA) Italy
ph. +39 0828 943688
fax +39 0828 943963

CORMIDI

25 Broad St, Norwalk 
CT 06851, USA
ph.+1 203-846-6120
art@cormidiusa.com