

CORMACH

16600 E
18000 E A.S.C.

Quality Management
ISO 9001
www.dekra-seal.com



www.cormach.com

16600 E - 18000 E A.S.C.

- Boccole in materiale autolubrificante.
- Bushes made in selflubricating material.
- Bagues en matériel auto-lubriifiant.
- Büchsen aus selbstschmierenden Material.

- Perni in acciaio speciale.
- Pins in special steel.
- Pivots en acier spécial.
- Bolzen aus spezialstahl.

Torretta con spallamenti allargati; l'ottima rigidità a torsione delle torrette delle gru Cormach è stato ulteriormente migliorato allargando le "spalle" della torretta.

Twist mast larger; the optimum torsion rigidity of the twist masts of the cranes Cormach had been too bettered enlarging the "shoulders" of twist mast.

Tourelle avec montants plus larges; l'optimum rigidité de torsion des tourelles des grues Cormach a été améliorée en élargissant les "montants" de la tourelle.

Turm mit erweiterten Schultern; der optimale Torsionswiderstand des Kranturms Cormac ist durch die Erweiterung der Turm-"Schulter" weiter verbessert worden.

·Braccio telescopico a sezione esagonale. Massima resistenza.

- Telescopic boom with hexagonal section. Greater resistance.
- Bras télescopique avec section hexagonale pour obtenir plus résistance.
- Hochste stabilität durch sechskantprofile am ausschub.

Corsa dei telescopici extralunga per uno sbraccio massimo idraulico di 12,23 m (versione E4).

Extra-long telescopic stroke for a maximum hydraulic extension of 12,23 m (version E4).

Extension des télescopiques extra-long pour une extension hydraulique maximum de 12,23 m (version E4).

Extralanger Hub der Teleskoparme mit einer maximalen hydraulischen Streckung von 12,23 m (Version E4).

Cuscinetto di base a rulli, massima resistenza, precisione di movimento, minimo attrito, nessuna usura.

Highly resistant base roller bearing, outstanding motion precision, very little friction, no wear.

Couronne à rouleaux pour obtenir résistance maximume, precision de mouvement, minimume friction et pas d'usure.

Der schrägrollengelagerte Drehkranz ermöglicht feinfühlig bewegungsabläufe, erzeugt niedrige reibung und ist äusserst verschleissfest.

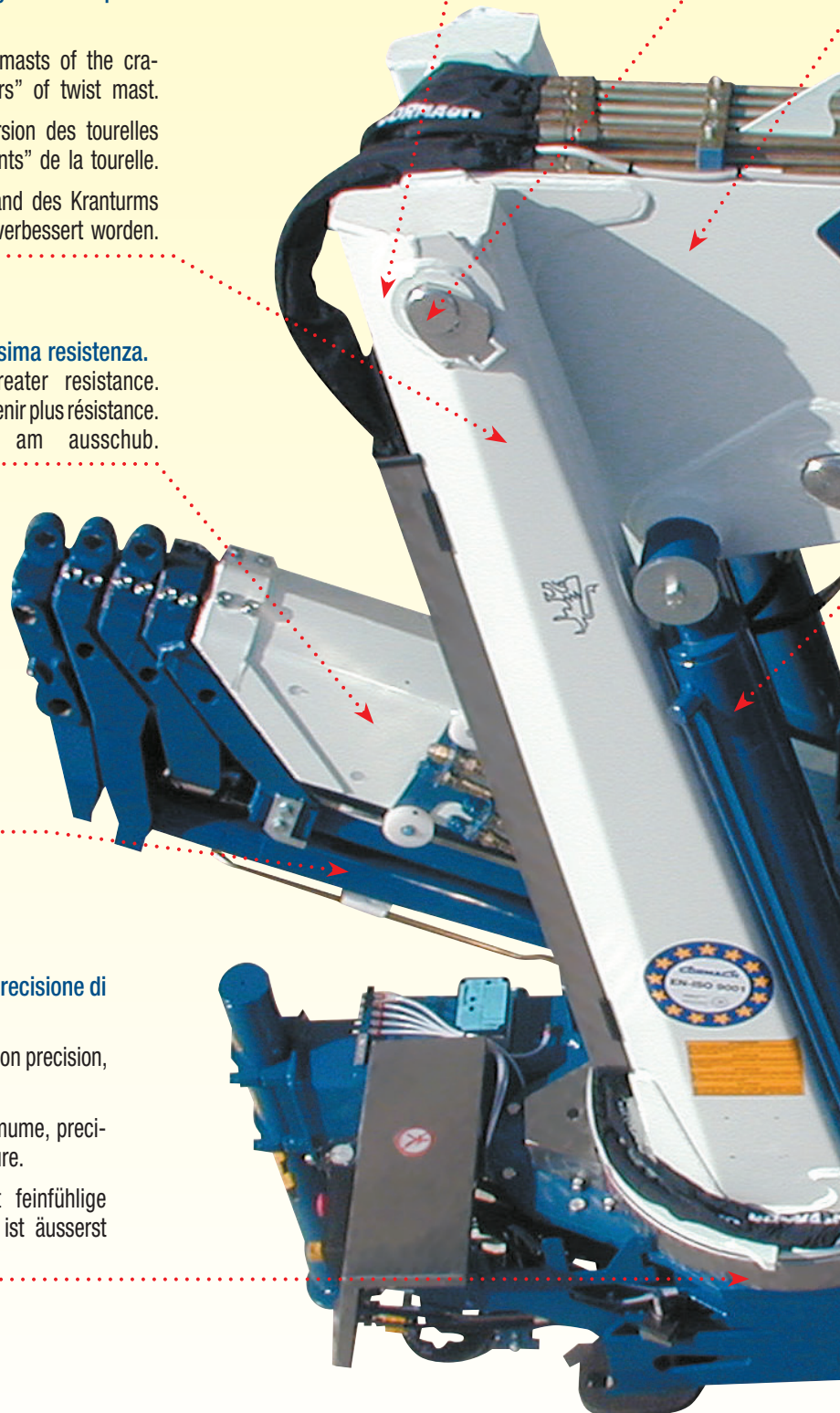

Braccio sagomato con sezione chiusa, massima resistenza a torsione e massima leggerezza della struttura.

Shaped arm with closed section, max. resistance to torsional stress, and light structure.

Bras façonné à coupe fermée permettant d'obtenir haute résistance à la torsion et structure très légère.

Durch die geschlossene konstruktion des hubarmes, wird eine hohe verdrehsteifigkeit bei geringem eigengewicht erreicht.

Massima potenza, n. 2 cilindri di sollevamento per maggior resistenza.

Outstanding power, 2 lifting cylinders granting higher resistance.

Puissance maximume, nr.2 verins de levage pour obtenir plus résistance.

2 haupthubzylinder erzeugen eine gleichmässige hubkraft und garantieren eine hohe betriebssicherheit.

Rotazione con motore riduttore: potenza, affidabilità, sensibilità al comando. Freno idraulico (a richiesta rotazione continua).

Rotation with engine and reduction gear, power, reability, remarkable drive sensibility. Hydraulic brake (option off continuous rotation).

Rotation par moto-réducteur avec frein hydraulique, puissance, fiabilité, sensibilité aux commandes. (Rotation continue sur demande).

Schwenkwerk angetrieben durch einen Hydraulikmotor mit untersectzungsgetriebe; betriebssicherheit durch hydraulische bremse; feinfühligere bewegungen beim schwenken des krans (endlosdrehung auf wunsch).

Valvola flangiata sui cilindri per maggior sicurezza.

Flanged valve on the cylinder for greater safety.

Soupape de sûreté flasquée sur les verins pour obtenir plus sécurité.

Direkt geflanschte ventile für ihre sicherheit.

Stabilizzatori extralarghi con cilindri di estensione protetti.

Wide outriggers extension with protected cylinders. Stabilisateur avec grande extension et verins protégés. Grosse abstützbreite mit abgedekten abstützylindern.

Attacco al telaio oscillante in conformita' alle specifiche dei maggiori costruttori di veicoli industriali.

3 point linkage as required by the leading truck manufactures.

Atelage à trois points en conformité aux prescriptions des principaux constructeurs de vehicules industriels.

3 punkt torsionsbrücke nach den aufbaubaurichtlinien der führenden LKW hersteller.

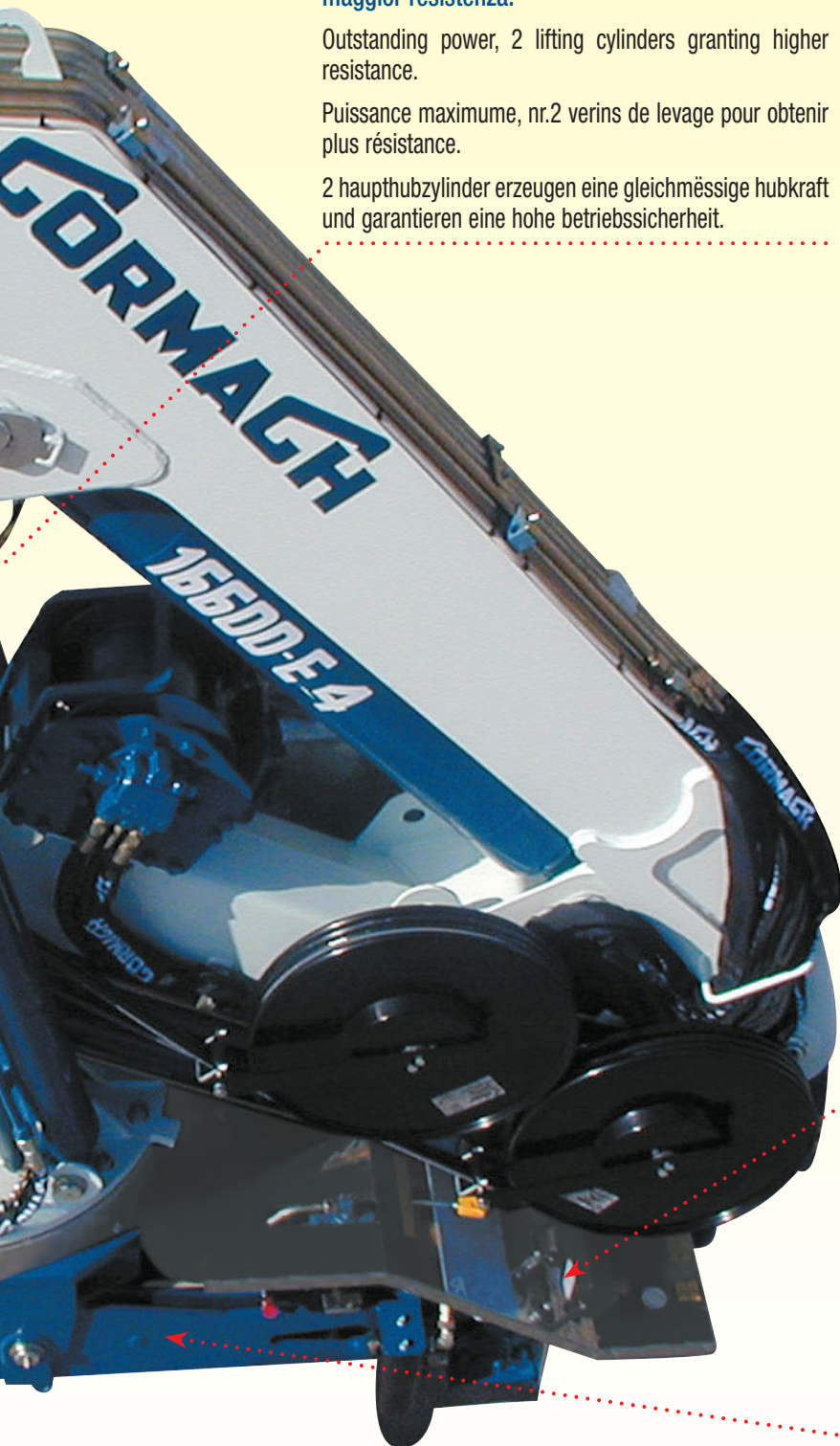

16600 E - 18000 E A.S.C.





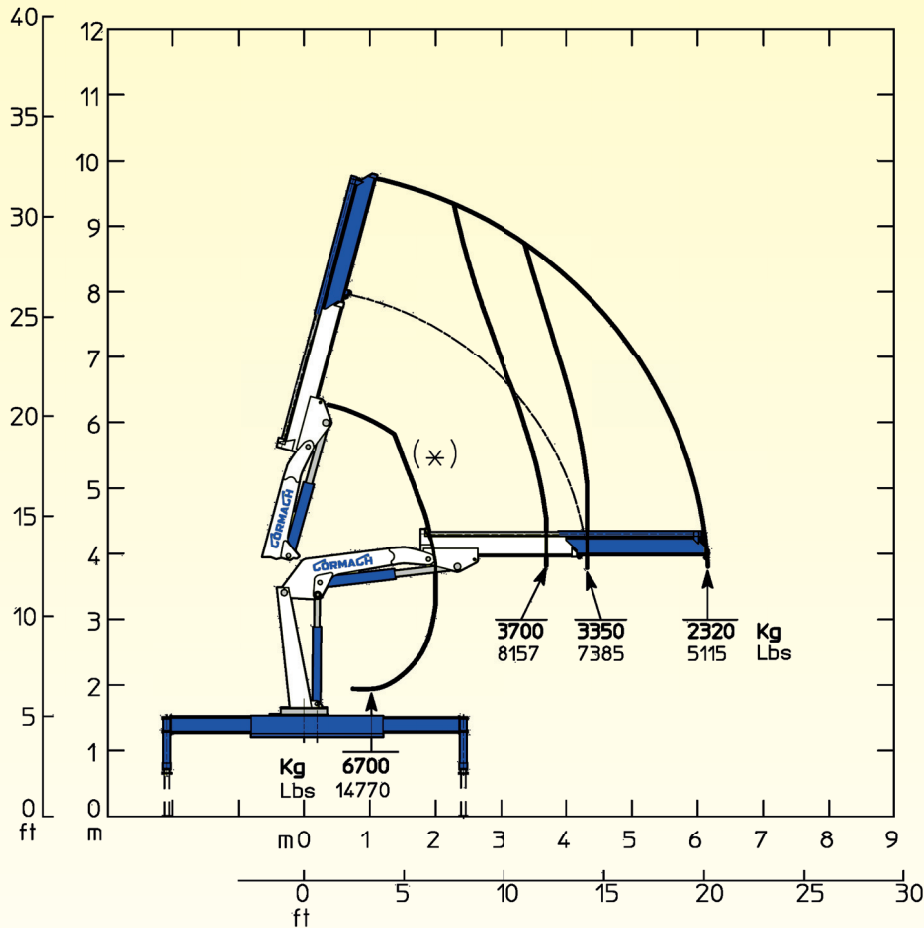

(*) Su gancio fisso (opzione), (*) On fixed hook (option), (*) Sur crochet fixe (option), (*) Auf festem Haken (option).

E1	E1	
16600 daN • m	120090 lbs • ft	Momento statico massimo al perno torretta • Max. static moment at the turret pin Moment statique max. a l'axe de la tourelle • Max. statisches ubmoment am kran Saulenbolzen
6,18 m	20'3"	Sbraccio idraulico • Hydraulic boom length Longueur du bras hydraulique • Hydraulic reichweite
16,50 m	54' 2"	Sbraccio con prolunghe manuali • Boom length with manual extensions Longueur du bras avec rallonges manuelles
1750 daN • m	12660 lbs • ft	Coppia di rotazione • Slew torque • Moment de rotation • Drehmoment
24 sec - 360°	24 sec - 360°	Tempo di rotazione • Slewing speed • Temp de rotation • Schwenkgeschwindigkeit
1606+1350 mm	5'3" + 4'5"	Uscita stabilizzatori • Outriggers extensions Sortie des bequilles • Breite der abstützung
5322 mm	17'6"	Larghezza stabilizzatori • Outriggers width Largeur des bequilles • Breite der abstützung
790 + 60 mm	2'7" + 0'2"	Lunghezza • Length • Longeur • Länge
2536 mm	8'4"	Larghezza • Width • Largeur • Breite
2310 mm	7'7"	Altezza • Height • Huteur • Höhe
1880 Kg	4145 Lbs	Peso (senza olio e montaggio) • Weight (without oil and fitting) Poids (sans huile et montage) • Gewicht (ohne öl und ohne)
35 lit /min	9 us gal/min	Portata pompa (*) • Pump delivery (*) • Capacité de la pompe (*) • Pumpenheistung (*)
290 bar	4123 psi	Pressione • Pressure • Pression • Druck
120 lit	31 us gal	Capacità serbatoio olio • Oil tank capacity • Capacité de reservoir d'huile • Öl tank inhalt

STANDARD

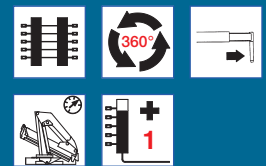

OPTIONAL

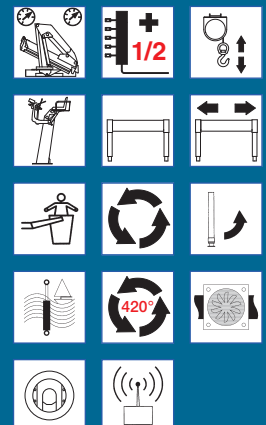

(*) Consigliata, (*) Recommended, (*) Reconnmandé, (*) Empfohlen.

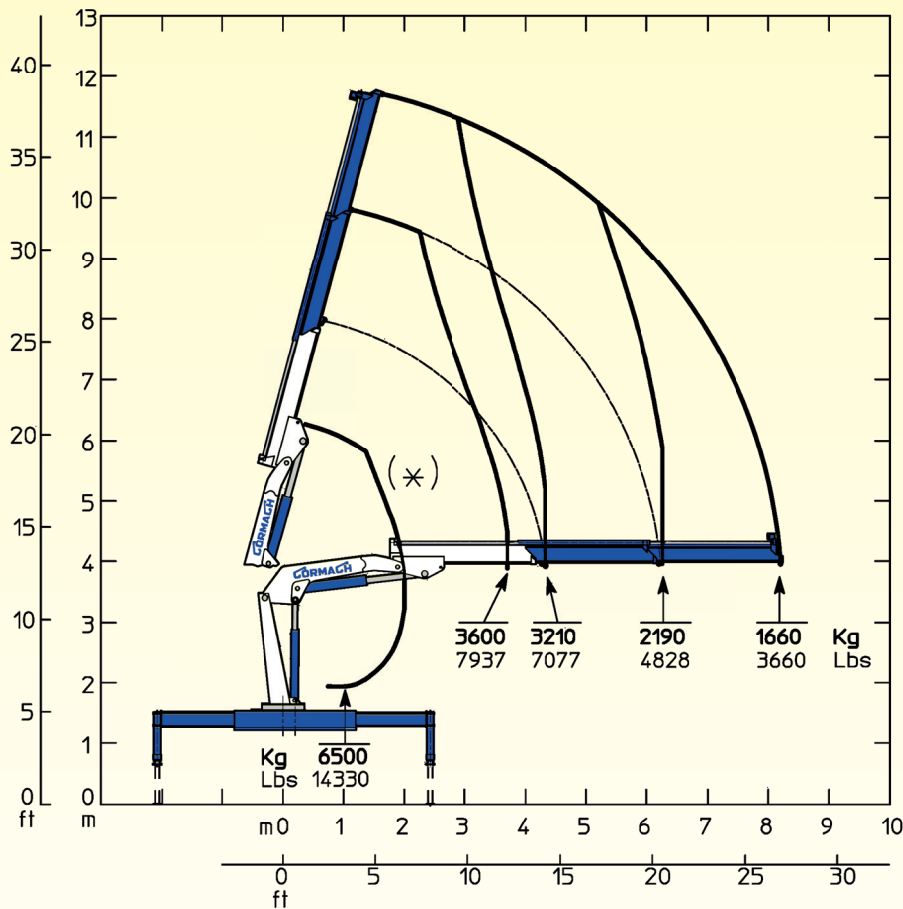

(*) Su gancio fisso (opzione), (*) On fixed hook (option), (*) Sur crochet fixe (option), (*) Auf festem Haken (option).

E2	E2	
16600 daN • m	120090 lbs • ft	Momento statico massimo al perno torretta • Max. static moment at the turret pin Moment statique max. a l'axe de la tourelle • Max. statisches ubmoment am kran Saulenbolzen
8,23 m	27'00"	Sbraccio idraulico • Hydraulic boom length Longueur du bras hydraulique • Hydraulic reichweite
16,47 m	54' 00"	Sbraccio con prolunghe manuali • Boom length with manual extensions Longueur du bras avec rallonges manuelles
1750 daN • m	12660 lbs • ft	Coppia di rotazione • Slew torque • Moment de rotation • Drehmoment
24 sec - 360°	24 sec - 360°	Tempo di rotazione • Slewing speed • Temp de rotation • Schwenkgeschwindigkeit
1606+1350 mm	5'3" + 4'5"	Uscita stabilizzatori • Outriggers extensions Sortie des bequilles • Breite der abstützung
5322 mm	17'6"	Larghezza stabilizzatori • Outriggers width Largeur des bequilles • Breite der abstützung
790 + 60 mm	2'7" + 0'2"	Lunghezza • Length • Longeur • Länge
2536 mm	8'4"	Larghezza • Width • Largeur • Breite
2310 mm	7'7"	Altezza • Height • Huteur • Höhe
2000 Kg	4409 Lbs	Peso (senza olio e montaggio) • Weight (without oil and fitting) Poids (sans huile et montage) • Gewicht (ohne öl und ohne)
35 lit /min	9 us gal/min	Portata pompa (*) • Pump delivery (*) • Capacité de la pompe (*) • Pumpenheistung (*)
290 bar	4123 psi	Pressione • Pressure • Pression • Druck
120 lt	31 us gal	Capacità serbatoio olio • Oil tank capacity • Capacité de reservoir d'huile • Öl tank inhalt

STANDARD

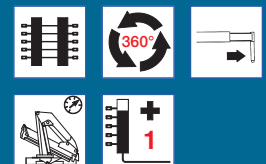

OPTIONAL

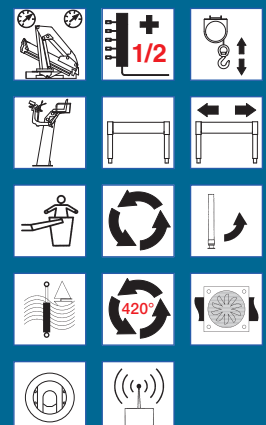

(*) Consigliata, (*) Recommended, (*) Reconnmandé, (*) Empfohlen.

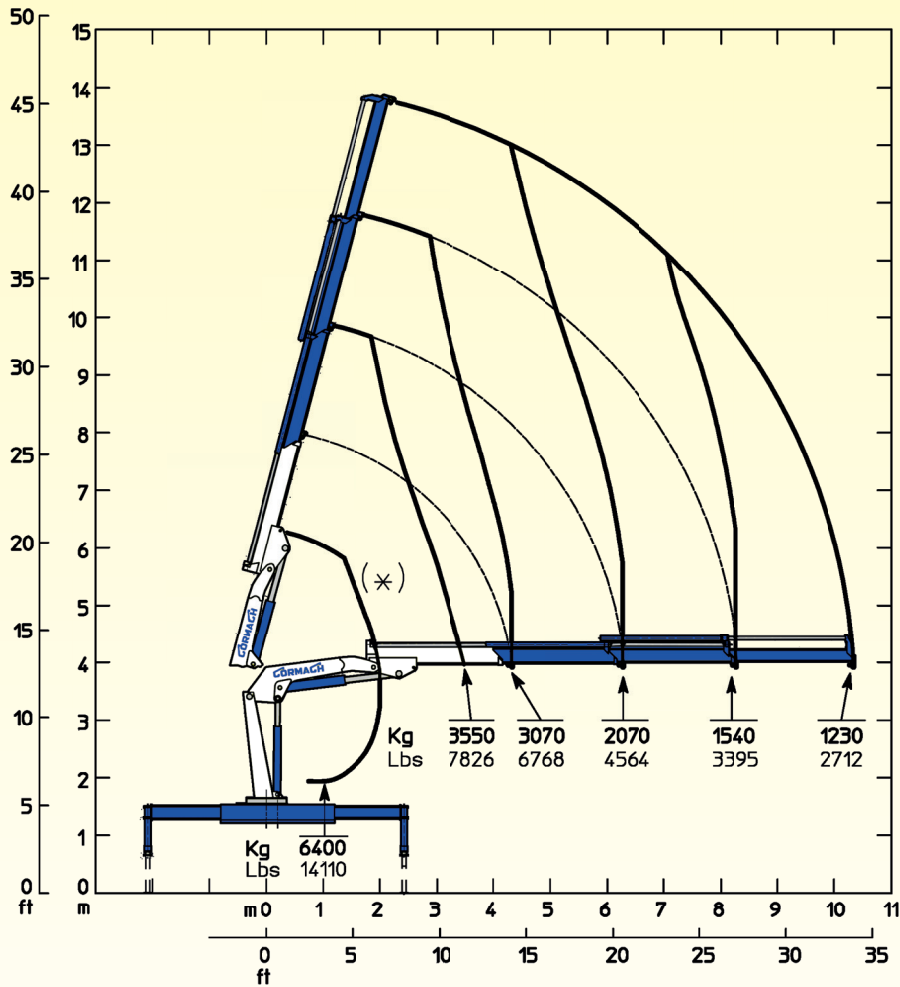

(*) Su gancio fisso (opzione), (*) On fixed hook (option), (*) Sur crochet fixe (option), (*) Auf festem haken (option).

E3	E3	
16600 daN • m	120090 lbs • ft	Momento statico massimo al perno torretta • Max. static moment at the turret pin Moment statique max. a l'axe de la tourelle • Max. statisches ubmoment am kran Saulenbolzen
10,27 m	33'8"	Sbraccio idraulico • Hydraulic boom length Longueur du bras hydraulique • Hydraulic reichweite
16,47 m	54' 00"	Sbraccio con prolunghe manuali • Boom length with manual extensions Longueur du bras avec rallonges manuelles
1750 daN • m	12660 lbs • ft	Coppia di rotazione • Slew torque • Moment de rotation • Drehmoment
24 sec - 360°	24 sec - 360°	Tempo di rotazione • Slewing speed • Temp de rotation • Schwenkgeschwindigkeit
1606+1350 mm	5'3" + 4'5"	Uscita stabilizzatori • Outriggers extensions Sortie des bequilles • Breite der abstützung
5322 mm	17'6"	Larghezza stabilizzatori • Outriggers width Largeur des bequilles • Breite der abstützung
790 + 60 mm	2'7" + 0'2"	Lunghezza • Length • Longeur • Länge
2536 mm	8'4"	Larghezza • Width • Largeur • Breite
2310 mm	7'7"	Altezza • Height • Huteur • Höhe
2150 Kg	4740 Lbs	Peso (senza olio e montaggio) • Weight (without oil and fitting) Poids (sans huile et montage) • Gewicht (ohne öl und ohne)
35 lit /min	9 us gal/min	Portata pompa (*) • Pump delivery (*) • Capacité de la pompe (*) • Pumpenheistung (*)
290 bar	4123 psi	Pressione • Pressure • Pression • Druck
120 lit	31 us gal	Capacità serbatoio olio • Oil tank capacity • Capacité de reservoir d'huile • Öl tank inhalt

STANDARD

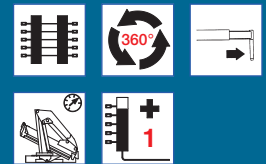

OPTIONAL

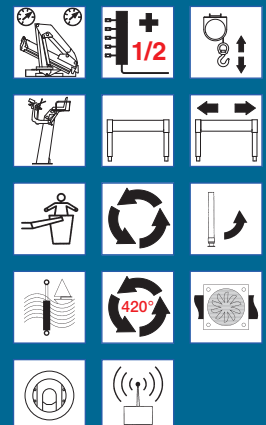

(*) Consigliata, (*) Recommended, (*) Reconnmandé, (*) Empfohlen.

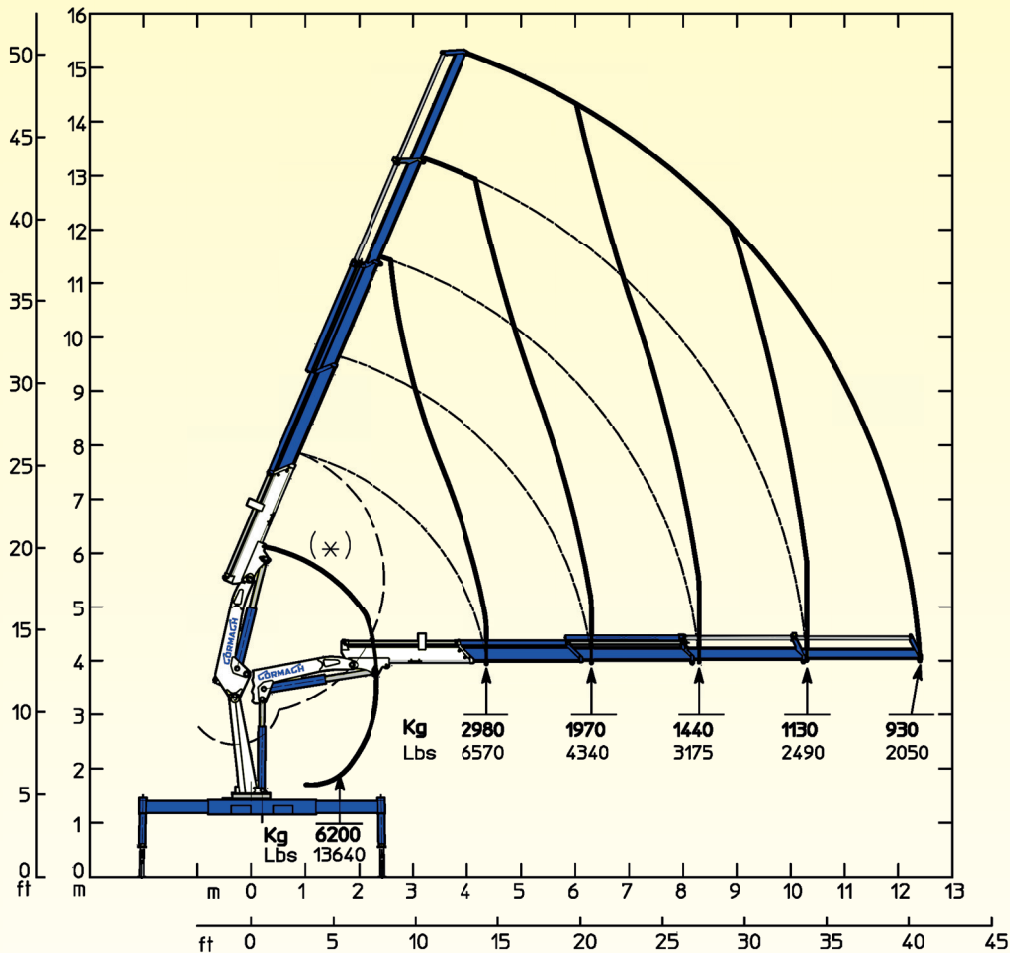

(*) Su gancio fisso (opzione), (*) On fixed hook (option), (*) Sur crochet fixe (option), (*) Auf festem Haken (option).

E4	E4	
16600 daN • m	120090 lbs • ft	Momento statico massimo al perno torretta • Max. static moment at the turret pin Moment statique max. a l'axe de la tourelle • Max. statisches ubmoment am kran-saulenbolzen
12,23 m	40'1"	Sbraccio idraulico • Hydraulic boom length Longueur du bras hydraulique • Hydraulic reichweite
16,36 m	53' 8"	Sbraccio con prolunghe manuali • Bomm length with manual extensions Longueur du bras avec rallonges manuelles
1750 daN • m	12660 lbs • ft	Coppia di rotazione • Slew torque • Moment de rotation • Drehmoment
24 sec - 360°	24 sec - 360°	Tempo di rotazione • Slewing speed • Temp de rotation • Schwenkgeschwindigkeit
1606+1350 mm	5'3"+4'5"	Uscita stabilizzatori • Outriggers extensions Sortie des bequilles • Breite der abstützung
5322 mm	17'6"	Larghezza stabilizzatori • Outriggers width Largeur des bequilles • Breite der abstützung
790 + 60 mm	2'7" + 0'2"	Lunghezza • Length • Longeur • Länge
2536 mm	8'4"	Larghezza • Width • Largeur • Breite
2310 mm	7'7"	Altezza • Height • Huteur • Höhe
2320 Kg	5115 Lbs	Peso (senza olio e montaggio) • Weight (without oil and fitting) Poids (sans huile et montage) • Gewicht (ohne öl und ohne)
35 lit /min	9 us gal/min	Portata pompa (*) • Pump delivery (*) • Capacité de la pompe (*) • Pumpenheistung (*)
290 bar	4123 psi	Pressione • Pressure • Pression • Druck
120 lt	31 us gal	Capacità serbatoio olio • Oil tank capacity • Capacité de reservoir d'huile • Öl tank inhalt

STANDARD

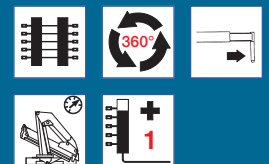

OPTIONAL

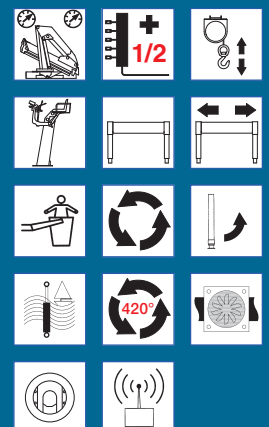

(*) Consigliata, (*) Recommended, (*) Reconnmandé, (*) Empfohlen.

16600 E4F

GORMAGH

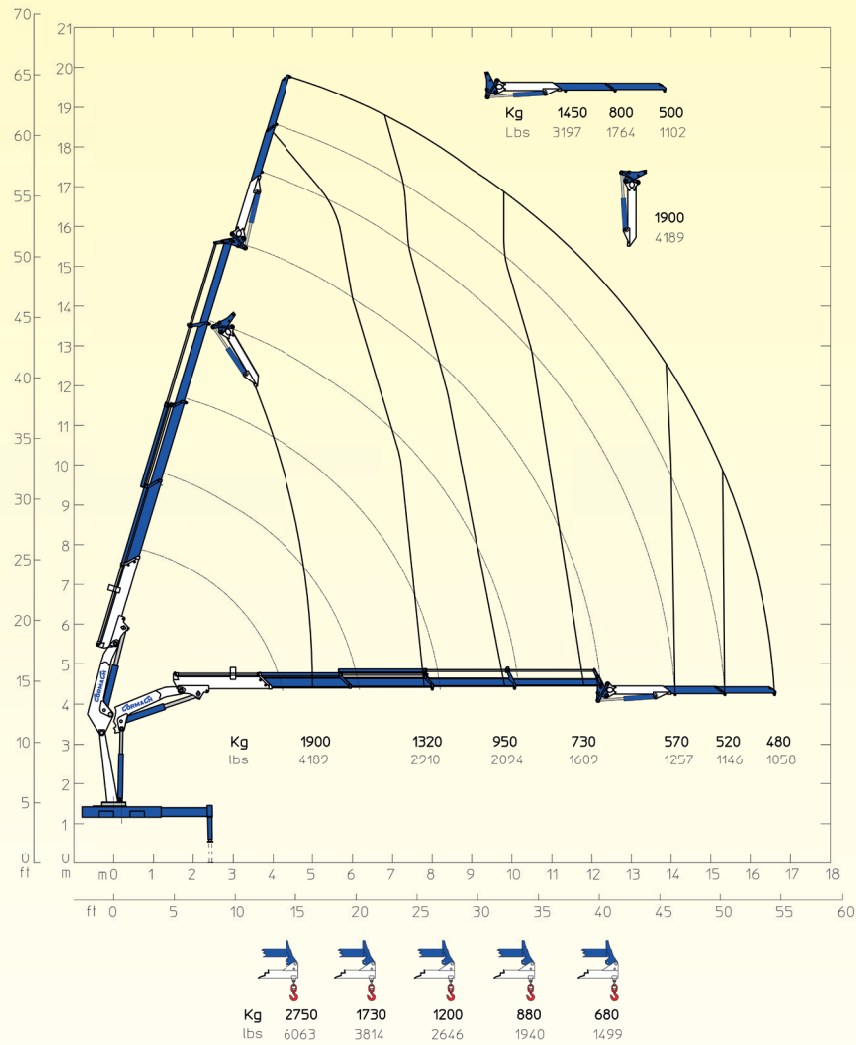

EF	EF	
16600 daN • m	120090 lbs • ft	Momento statico massimo al perno torretta • Max. static moment at the turret pin Moment statique max. a l'axe de la tourelle • Max. statisches ubmoment am kranstaulenbolzen
16,60 m	54'6"	Sbraccio idraulico • Hydraulic boom length Longueur du bras hydraulique • Hydraulic reichweite
18,60 m	61' 00"	Sbraccio con prolunghe manuali • Boom length with manual extensions Longueur du bras avec rallonges manuelles
1750 daN • m	12660 lbs • ft	Coppia di rotazione • Slew torque • Moment de rotation • Drehmoment
24 sec - 360°	24 sec - 360°	Tempo di rotazione • Slewing speed • Temp de rotation • Schwenkgeschwindigkeit
1606+1350 mm	5'3" + 4'5"	Uscita stabilizzatori • Outriggers extensions Sortie des bequilles • Breite der abstützung
5322 mm	17'6"	Larghezza stabilizzatori • Outriggers width Largeur des bequilles • Breite der abstützung
790 + 60 mm	2'7" + 0'2"	Lunghezza • Length • Longeur • Länge
2536 mm	8'4"	Larghezza • Width • Largeur • Breite
2310 mm	7'7"	Altezza • Height • Huteur • Höhe
2630 Kg	5798 Lbs	Peso (senza olio e montaggio) • Weight (without oil and fitting) Poids (sans huile et montage) • Gewicht (ohne öl und ohne)
35 lit /min	9 us gal/min	Portata pompa (*) • Pump delivery (*) • Capacité de la pompe (*) • Pumpenheistung (*)
290 bar	4123 psi	Pressione • Pressure • Pression • Druck
120 lit	31 us gal	Capacità serbatoio olio • Oil tank capacity • Capacité de reservoir d'huile • Öl tank inhalt

STANDARD

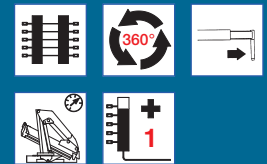

OPTIONAL

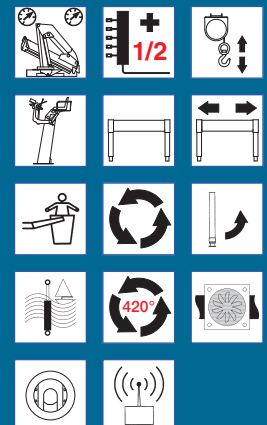

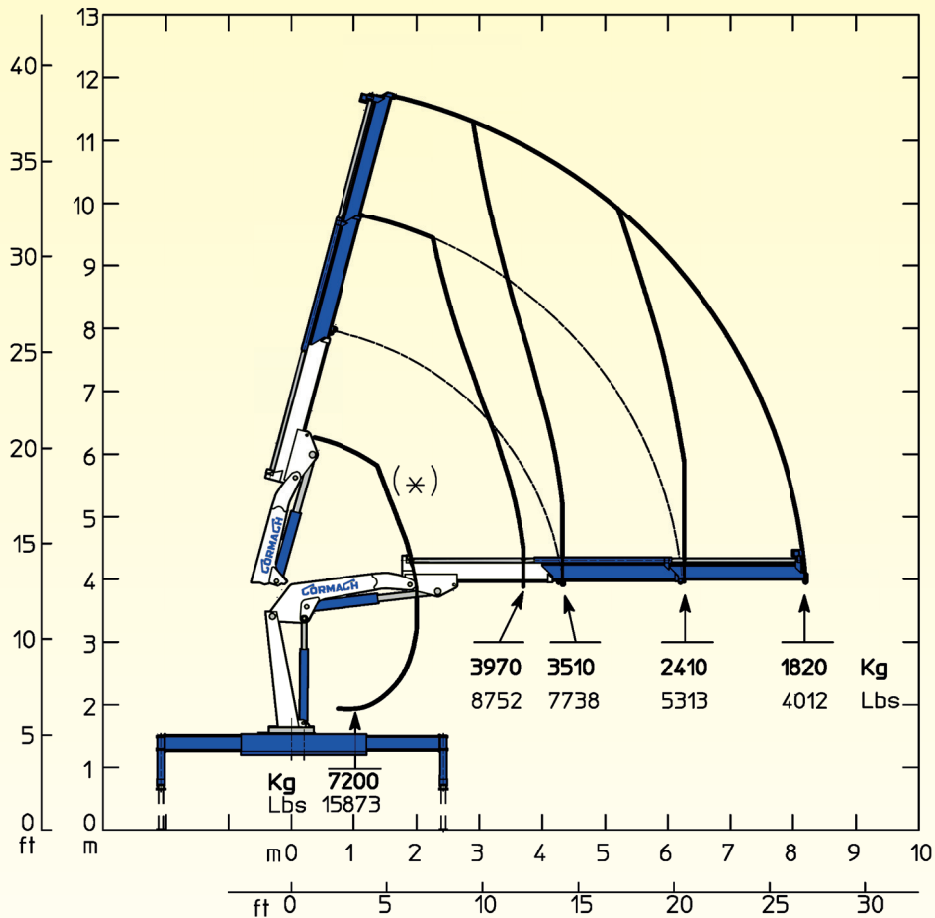

(*) Su gancio fisso (opzione), (*) On fixed hook (option), (*) Sur crochet fixe (option), (*) Auf festem Haken (option).

E2	E2	
18000 daN • m	130219 lbs • ft	Momento statico massimo al perno torretta • Max. static moment at the turret pin Moment statique max. a l'axe de la tourelle • Max. statisches ubmoment am kran-saulenbolzen
8,23 m	27'00"	Sbraccio idraulico • Hydraulic boom length Longueur du bras hydraulique • Hydraulic reichweite
12,38 m	40' 7"	Sbraccio con prolunghe manuali • Bomm length with manual extensions Longueur du bras avec rallonges manuelles
1750 daN • m	12660 lbs • ft	Coppia di rotazione • Slew torque • Moment de rotation • Drehmoment
24 sec - 360°	24 sec - 360°	Tempo di rotazione • Slewing speed • Temp de rotation • Schwenkgeschwindigkeit
1606+1350 mm	5'3"+4'5"	Uscita stabilizzatori • Outriggers extensions Sortie des bequilles • Breite der abstützung
5322 mm	17'6"	Larghezza stabilizzatori • Outriggers width Largeur des bequilles • Breite der abstützung
790 + 60 mm	2'7" + 0'2"	Lunghezza • Length • Longeur • Länge
2536 mm	8'4"	Larghezza • Width • Largeur • Breite
2310 mm	7'7"	Altezza • Height • Huteur • Höhe
2000 Kg	4409 Lbs	Peso (senza olio e montaggio) • Weight (without oil and fitting) Poids (sans huile et montage) • Gewicht (ohne öl und ohne)
35 lit /min	9 us gal/min	Portata pompa (*) • Pump delivery (*) • Capacité de la pompe (*) • Pumpenheistung (*)
290 bar	4123 psi	Pressione • Pressure • Pression • Druck
120 lit	31 us gal	Capacità serbatoio olio • Oil tank capacity • Capacité de reservoir d'huile • Öl tank inhalt

STANDARD

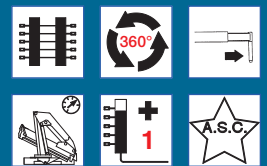

OPTIONAL

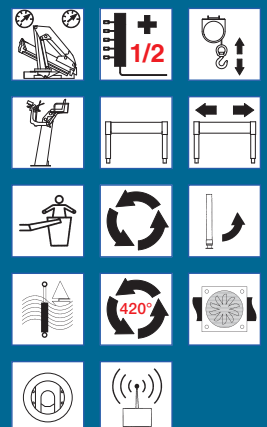

(*) Consigliata, (*) Recommended, (*) Reconnmandé, (*) Empfohlen.

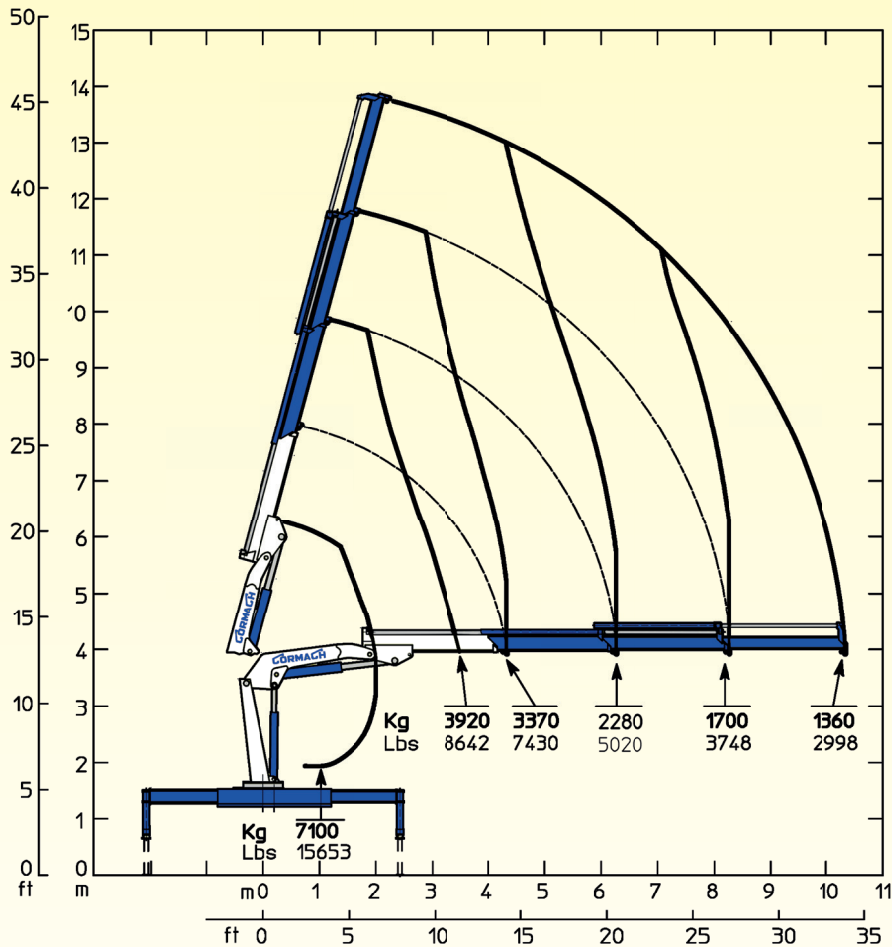

(*) Su gancio fisso (opzione), (*) On fixed hook (option), (*) Sur crochet fixe (option), (*) Auf festem Haken (option).

E3	E3	
18000 daN • m	130219 lbs • ft	Momento statico massimo al perno torretta • Max. static moment at the turret pin Moment statique max. a l'axe de la tourelle • Max. statisches ubmoment am kranstaulenbolzen
10,27 m	33'8"	Sbraccio idraulico • Hydraulic boom length Longueur du bras hydraulique • Hydraulic reichweite
12,38 m	40' 7"	Sbraccio con prolunghe manuali • Boom length with manual extensions Longueur du bras avec rallonges manuelles
1750 daN • m	12660 lbs • ft	Coppia di rotazione • Slew torque • Moment de rotation • Drehmoment
24 sec - 360°	24 sec - 360°	Tempo di rotazione • Slewing speed • Temp de rotation • Schwenkgeschwindigkeit
1606+1350 mm	5'3" + 4'5"	Uscita stabilizzatori • Outriggers extensions Sortie des bequilles • Breite der abstützung
5322 mm	17'6"	Larghezza stabilizzatori • Outriggers width Largeur des bequilles • Breite der abstützung
790 + 60 mm	2'7" + 0'2"	Lunghezza • Length • Longeur • Länge
2536 mm	8'4"	Larghezza • Width • Largeur • Breite
2310 mm	7'7"	Altezza • Height • Huteur • Höhe
2150 Kg	4740 Lbs	Peso (senza olio e montaggio) • Weight (without oil and fitting) Poids (sans huile et montage) • Gewicht (ohne öl und ohne)
35 lit /min	9 us gal/min	Portata pompa (*) • Pump delivery (*) • Capacité de la pompe (*) • Pumpenheistung (*)
290 bar	4123 psi	Pressione • Pressure • Pression • Druck
120 lt	31 us gal	Capacità serbatoio olio • Oil tank capacity • Capacité de reservoir d'huile • Öl tank inhalt

STANDARD

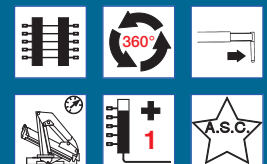

OPTIONAL

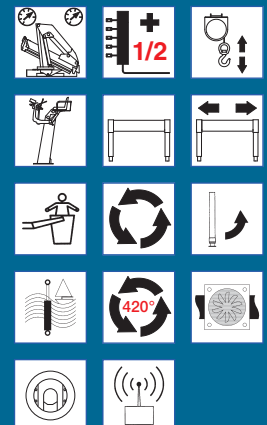

(*) Consigliata, (*) Recommended, (*) Reconnmandé, (*) Empfohlen.

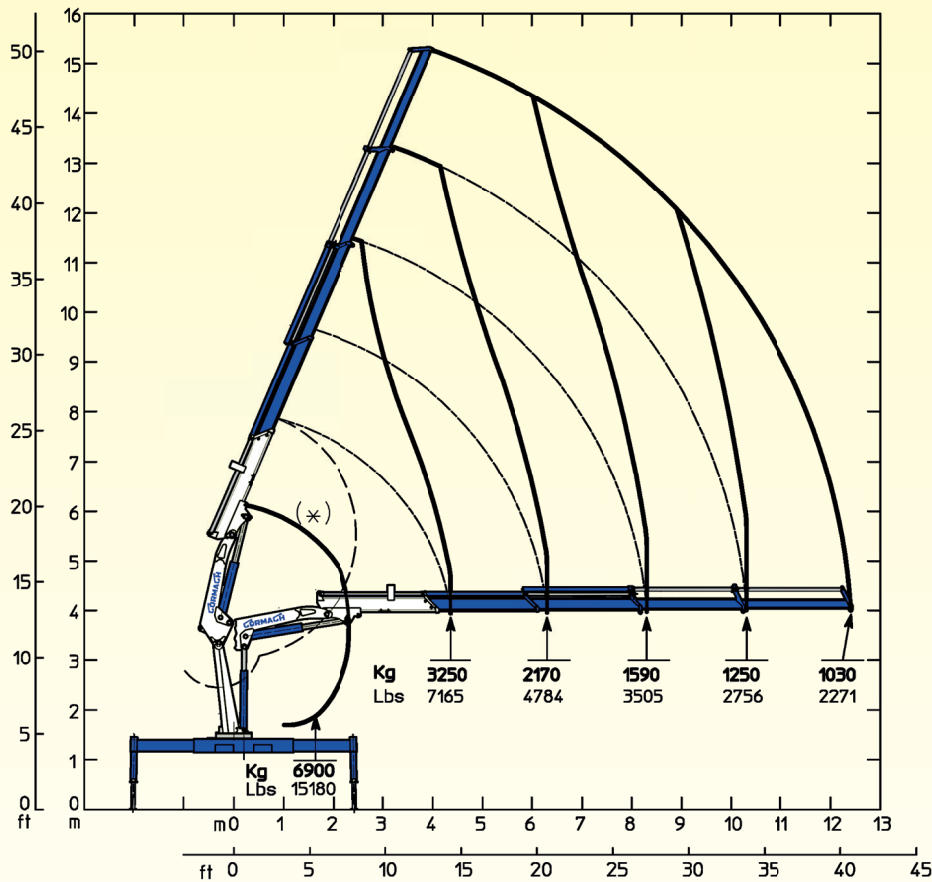

(*) Su gancio fisso (opzione), (*) On fixed hook (option), (*) Sur crochet fixe (option), (*) Auf festem Haken (option).

E4	E4	
18000 daN • m	130219 lbs • ft	Momento statico massimo al perno torretta • Max. static moment at the turret pin Moment statique max. a l'axe de la tourelle • Max. statisches ubmoment am kran-saulenbolzen
12,23 m	40'1"	Sbraccio idraulico • Hydraulic boom length Longueur du bras hydraulique • Hydraulic reichweite
14,29	46' 11"	Sbraccio con prolunghe manuali • Bomm length with manual extensions Longueur du bras avec rallonges manuelles
1750 daN • m	12660 lbs • ft	Coppia di rotazione • Slew torque • Moment de rotation • Drehmoment
24 sec - 360°	24 sec - 360°	Tempo di rotazione • Slewing speed • Temp de rotation • Schwenkgeschwindigkeit
1606+1350 mm	5'3"+4'5"	Uscita stabilizzatori • Outriggers extensions Sortie des bequilles • Breite der abstützung
5322 mm	17'6"	Larghezza stabilizzatori • Outriggers width Largeur des bequilles • Breite der abstützung
790 + 60 mm	2'7" + 0'2"	Lunghezza • Length • Longeur • Länge
2536 mm	8'4"	Larghezza • Width • Largeur • Breite
2310 mm	7'7"	Altezza • Height • Huteur • Höhe
2320 Kg	5115 Lbs	Peso (senza olio e montaggio) • Weight (without oil and fitting) Poids (sans huile et montage) • Gewicht (ohne öl und ohne)
35 lit /min	9 us gal/min	Portata pompa (*) • Pump delivery (*) • Capacité de la pompe (*) • Pumpenheistung (*)
290 bar	4123 psi	Pressione • Pressure • Pression • Druck
120 lit	31 us gal	Capacità serbatoio olio • Oil tank capacity • Capacité de reservoir d'huile • Öl tank inhalt

STANDARD

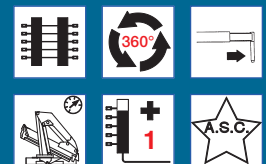

OPTIONAL

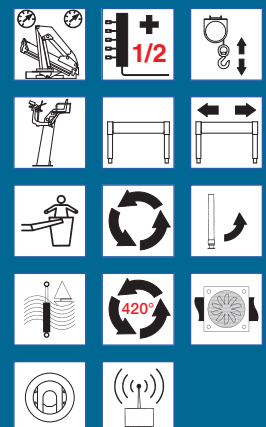

(*) Consigliata, (*) Recommended, (*) Reconnmandé, (*) Empfohlen.

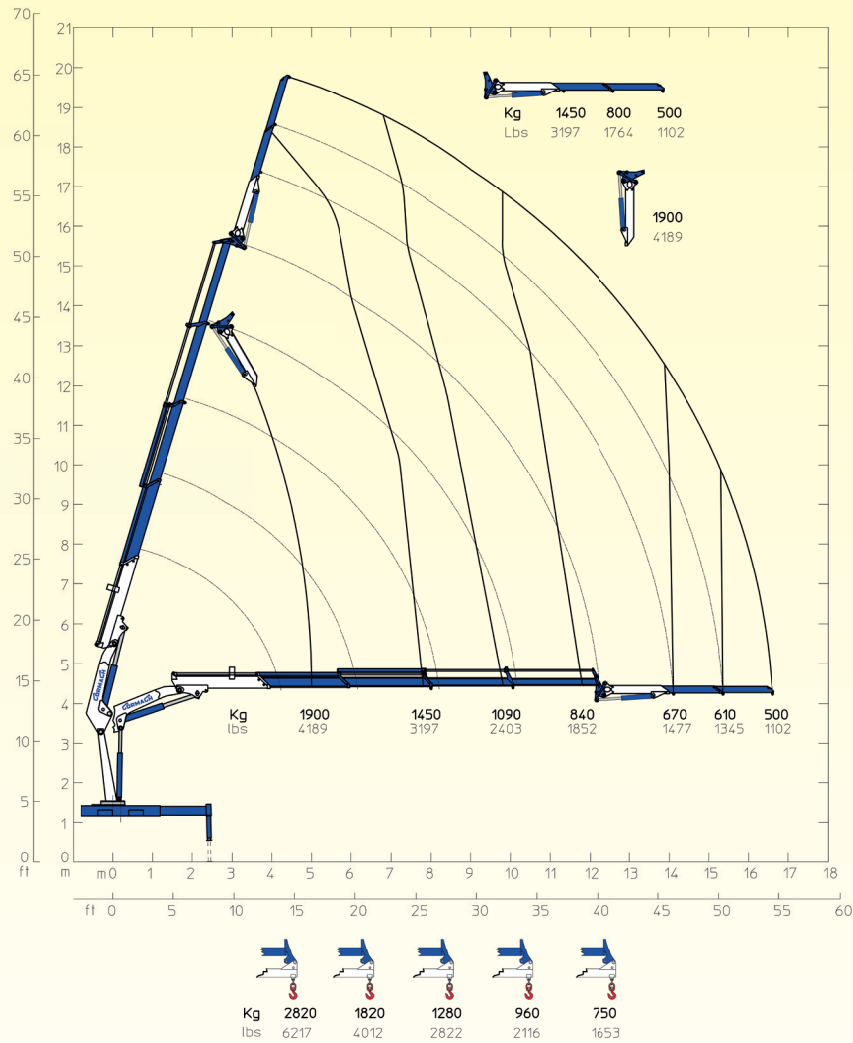

EF	EF	
18000 daN • m	130219 lbs • ft	Momento statico massimo al perno torretta • Max. static moment at the turret pin Moment statique max. a l'axe de la tourelle • Max. statisches ubmoment am kran Saulenbolzen
16,60 m	54'6"	Sbraccio idraulico • Hydraulic boom length Longueur du bras hydraulique • Hydraulic reichweite
18,60 m	61' 00"	Sbraccio con prolunghe manuali • Boom length with manual extensions Longueur du bras avec rallonges manuelles
1750 daN • m	12660 lbs • ft	Coppia di rotazione • Slew torque • Moment de rotation • Drehmoment
24 sec - 360°	24 sec - 360°	Tempo di rotazione • Slewing speed • Temp de rotation • Schwenkgeschwindigkeit
1606+1350 mm	5'3" +4'5"	Uscita stabilizzatori • Outriggers extensions Sortie des bequilles • Breite der abstützung
5322 mm	17'6"	Larghezza stabilizzatori • Outriggers width Largeur des bequilles • Breite der abstützung
790 + 60 mm	2'7" + 0'2"	Lunghezza • Length • Longeur • Länge
2536 mm	8'4"	Larghezza • Width • Largeur • Breite
2310 mm	7'7"	Altezza • Height • Huteur • Höhe
2630 Kg	5798 Lbs	Peso (senza olio e montaggio) • Weight (without oil and fitting) Poids (sans huile et montage) • Gewicht (ohne öl und ohne)
35 lit /min	9 us gal/min	Portata pompa (*) • Pump delivery (*) • Capacité de la pompe (*) • Pumpenheistung (*)
290 bar	4123 psi	Pressione • Pressure • Pression • Druck
120 lt	31 us gal	Capacità serbatoio olio • Oil tank capacity • Capacité de reservoir d'huile • Öl tank inhalt

STANDARD

-
-

OPTIONAL

-
-
-
-

(*) Consigliata, (*) Recommended, (*) Reconnmandé, (*) Empfohlen.

16600 E - 18000 E A.S.C.

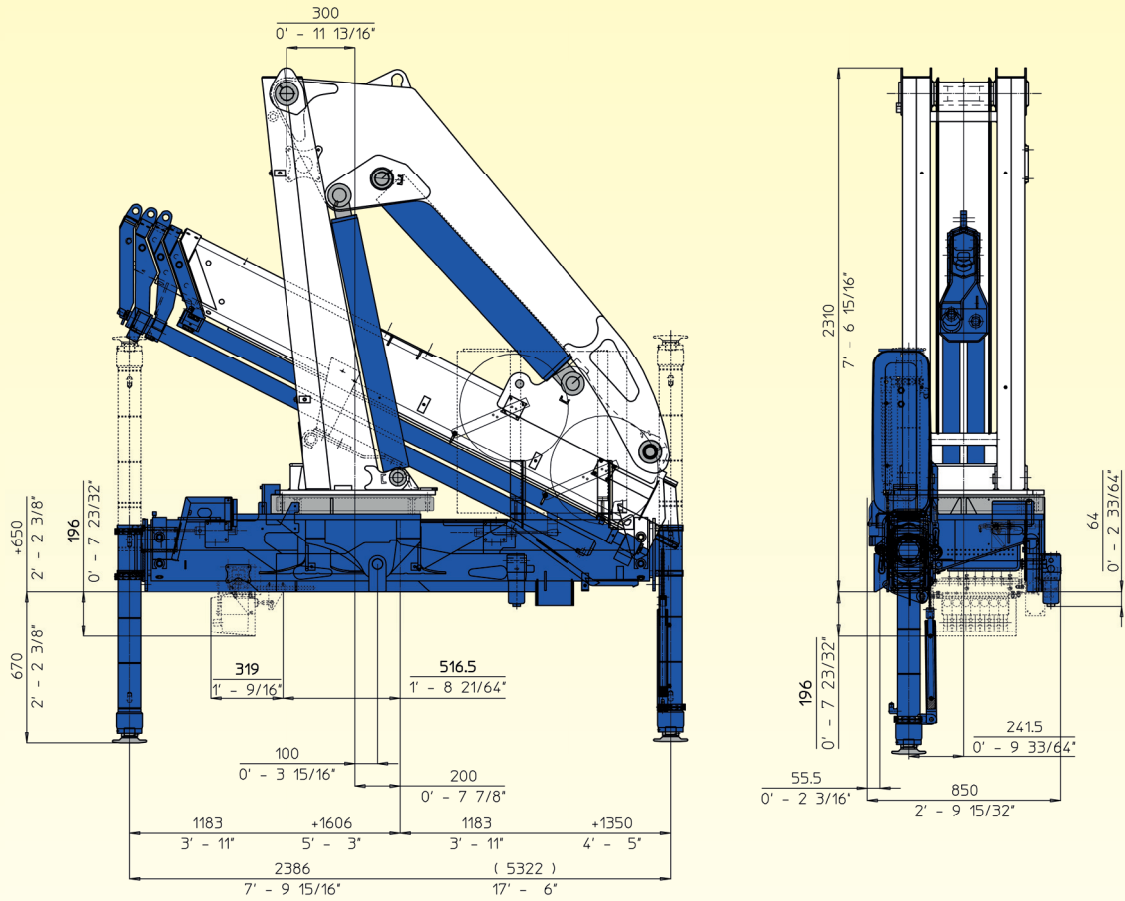

STANDARD

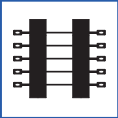

Comandi bilaterali
Dual control stations
Commandes à gauche et à droite
Beidseitige Bedienung



Rotazione 360°
Rotation 360°
Rotation 360°
Drehbereich 360°

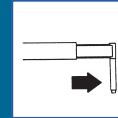

Stabilizzatori gru base estendibili idraulicamente
Outriggers with hydraulic
Stabilisateurs avec extension hydraulique
Hydraulisch ausfahrbare stützen



Limitatore di momento
Load limiting device
Limiteur de charge
Überlastabschal tungssystem



Comando supplementare non attivato (1)
Additional free section not actived (1)
Section du distributeur pas activé (1)
Zusätzlicher steuerschieber (1)



Automatic Speed Control (SOLO 18000 E A.S.C.)
Automatic Speed Control (ONLY 18000 E A.S.C.)
Automatic Speed Control (SEULEMENT 18000 E A.S.C.)
Automatic Speed Control (NUR 18000 E A.S.C.)

OPTIONAL

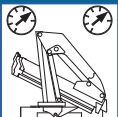

Doppio limitatore di momento
Double load limiting device
Double limiteur de charge
Doppel Überlastabschal tungssystem



Comando supplementare attivato (1/2)
Additional function (1/2)
Section du distributeur activée (1/2)
Zusatzfunktion (1/2)



Verricello
Winch
Treuil
Seilwinde

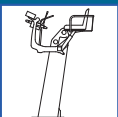

Posto di manovra in alto
Top seat
Siege en haut
Hochsitz

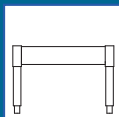

Traversa ausiliaria fissa
Additional outriggers beam without extension
Stabilisateur supplementaires sans elargissement
Zusätzliche abstützbeine

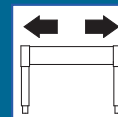

Traversa ausiliaria estendibile
Additional outriggers with lateral extension
Stabilisateur supplementaires avec elargissement
Ausfahrbare zusatz- stützen



Cestello
Basket
Nacelle
Personenkorb



Rotazione continua
Continuos rotation
Rotation continue
Endlos schwenkwerk

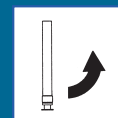

Stabilizzatori gru base girevoli
Tilt up outriggers
Bequilles tournants
Drehbare stützen



Trattamento marino della gru
Marine treatment of the crane
Trattement marine de la grue
Marine behandlung des kranes



Rotazione 420°
Rotation 420°
Rotation 420°
Drehbereich 420°

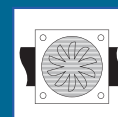

Scambiatore di calore
Oil cooler
Echangeur de chaleur
Ölkühler



Piastre di appoggio maggiorate
Large ground plates
Plaques stabilisateurs
Bodenplatten



Radiocomando
Radio remote control
Radiocommandes
Funkfernsteuerung



CORMACH

Cormach s.r.l. - Via Madonnina, 27 - C.P. 199 - 25018 MONTICHIARI (BS) - ITALY
Tel. 0039.030.9656811 - Telefax 0039.030.9656846.7.8
E-mail: info@cormach.com - www.cormach.com

A fronte di una continua ricerca tecnologica i dati possono cambiare senza preavviso. Contattare il nostro Ufficio Commerciale per ulteriori informazioni.
Because of continuous technology research data can change without notice. Please, contact our Commercial Dept. for further information.
A cause de une continue recherche technologique les données peuvent changer sans préavis. Contacter notre Bureau Commercial pour des autres informations.
Irrtum und technische Änderung vorbehalten masse und gewichte unverbindlich. Unser Vertrieb erteilt Ihnen gerne weitere Auskünfte. Bitte rufen Sie uns an.
Debito a los continuos avances tecnológicos los datos pueden variar sin notificación previa. Para más información rogamos contacten nuestro Departamento Comercial.