



PE120FE-BASCUL

Ensemble composé du pétrin modèle PE120FE et d'un levier hydraulique basculant

Châssis en acier et carbone
 Garde corps de protection

2 hauteurs d'élévation, 140 cm ou 180 cm
 Montée et descente par vérin hydraulique
 Valve de sécurité pour la descente en cas de chute de pression

PE120FE-BASCUL

Set including PE120FE kneader and a hydraulic lifter

Structure in carbon steel
 Safety bar against accidents

2 heights of rise 140 cm or 180 cm
 Hydraulic cylinder for lifting and lowering
 Safety valve for lowering in case of pressure failure

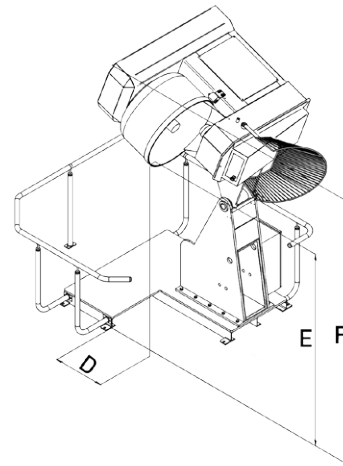
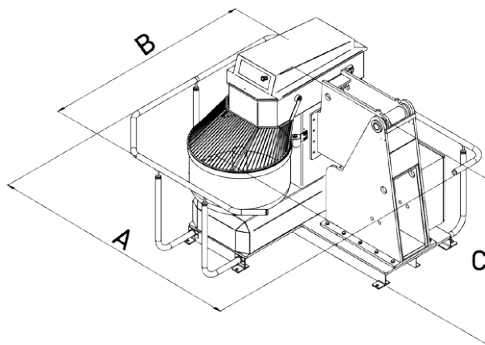

PE120FE-BASCUL234

PE120FE-BASCUL274

Dimensions / Dimensions

A mm	1984	2182
B mm	1922	1922
C mm	1535	1535
D mm	90	290
E mm	1450	1850
F mm	2340	2740

Poids / Weight

Kg	1325	1475
----	------	------

Puissance du système hydraulique / Hydraulic system power

kW	1.5	1.5
----	-----	-----

Voltage / Voltage

TRI - 400V - 50/60Hz