



BPS-200

BPS-300

BPS-600

BPS-2000 HP

BPS-2000 HF

BPS-4000

BETTER PUMPS FOR BETTER YIELD!

No Seals, No Bearings,
No Particle Contamination.

BPS-series

LEVITRONIX[®]

REVOLUTIONARY MAGNETICALLY LEVITATED CENTRIFUGAL PUMP

The BPS pump system is a revolutionary centrifugal pump that has no bearings to wear out or seals to break down and fail. Based on the principles of magnetic levitation, the pump's impeller is suspended, contact-free, inside a sealed casing and is driven by the magnetic field of the motor. The impeller and casing are both fabricated from chemical-resistant high purity fluorocarbon resins. Fluid flow rate and pressure are precisely controlled electronically regulating the impeller speed

Two basic system configurations are available. The stand-alone configuration consists of a controller with an integrated user panel to set the speed manually. The extended version consists of a controller with integrated PLC interface. This allows setting the speed by an external signal and enables precise flow or pressure control in connection with either a flow or a pressure sensor.

Schematic of the main elements of the maglev centrifugal pump

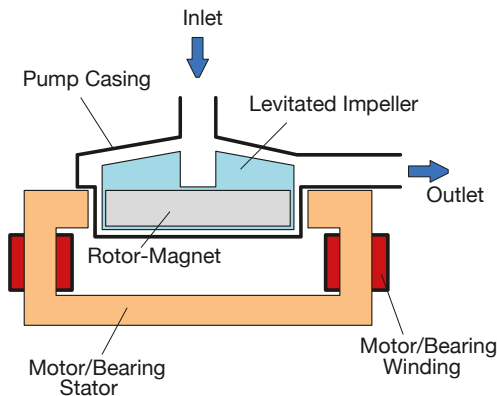

Maglev pump motor with pump head

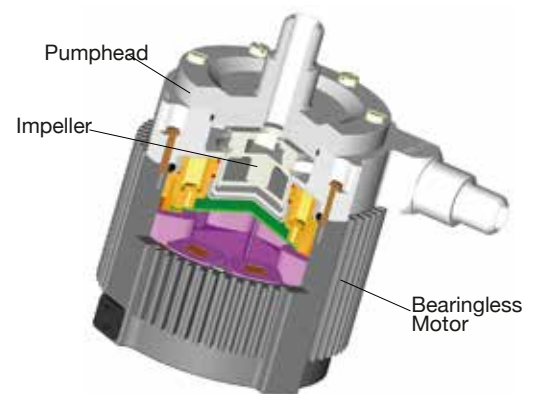

Disassembled pump head

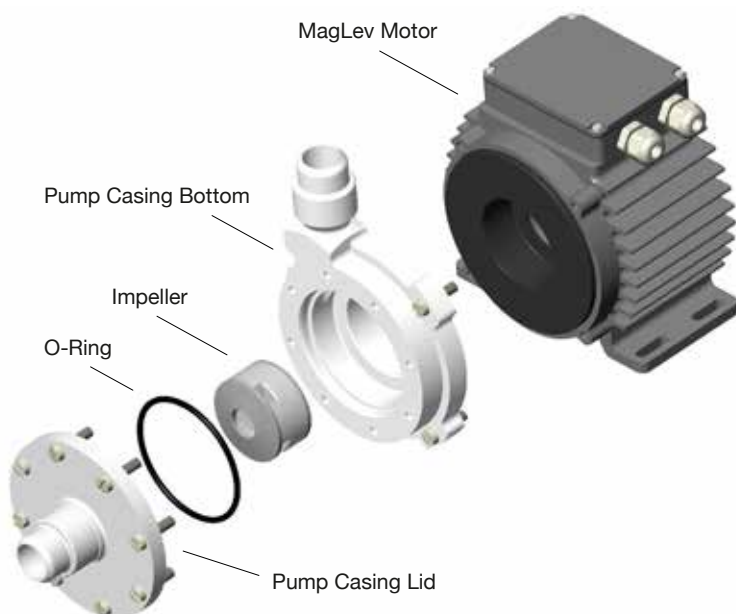

SYSTEM BENEFITS

- Extremely low particle generation due to the absence of mechanically contacting parts
- Increased equipment uptime
- Lower maintenance costs by eliminating valves, bearings, rotating seals and costly rebuilds
- Reduced risk of contamination due to the self-contained design with magnetic bearings
- Very gentle to sensitive fluids due to low-shear design
- No narrow gaps and fissures where particles or microorganisms could become entrapped
- Smooth, continuous flow without pressure pulsation
Electronic speed control
- Compact design compared to pneumatic and mag-drive pumps
- Proven technology in medical and semiconductor industry (MTBF 50-100 years)

BPS-SERIES - MAX PRESSURE / FLOW CURVES

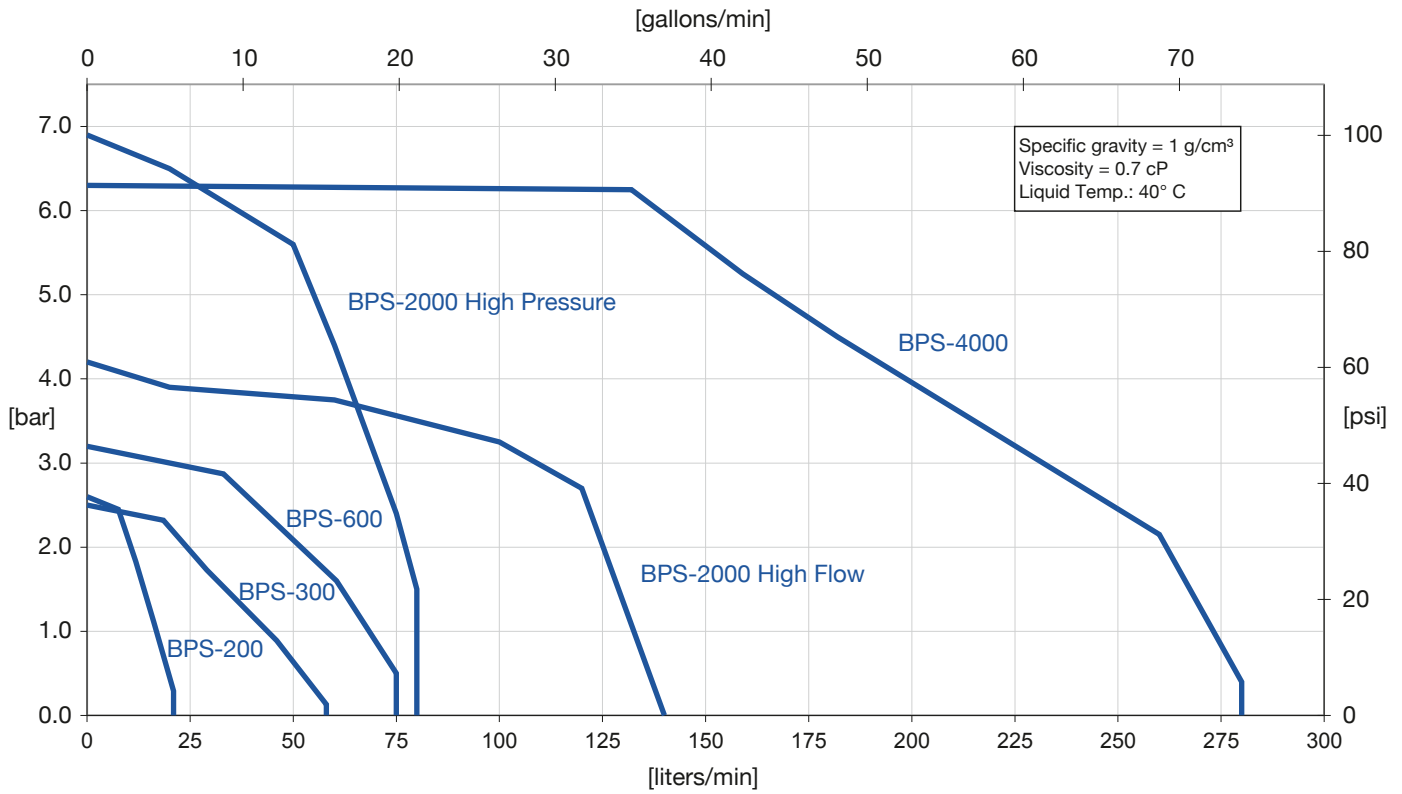

STANDALONE CONFIGURATION

System Configuration for Standalone Operation
 (Speed setting with integrated user panel)

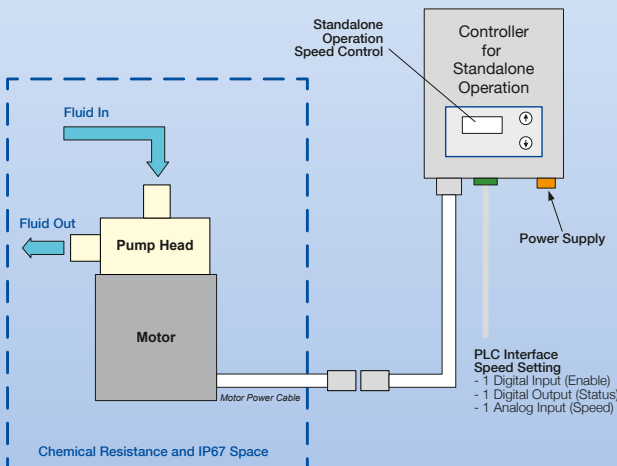

EXTENDED CONFIGURATION

Extended Operation (Flow or Pressure Control)
 with Extended Controller

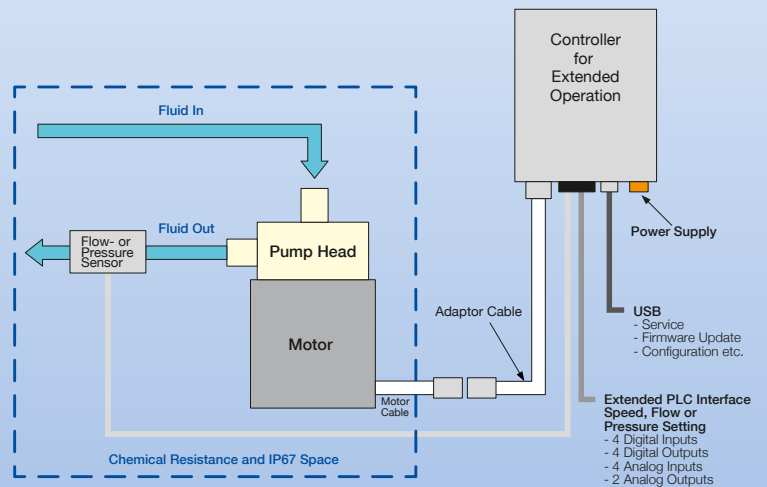

LEVITRONIX® The Company

Levitronix® is the world-wide leader in magnetically levitated bearingless motor technology. Levitronix® was the first company to introduce bearingless motor technology to the medical and industrial markets.

The company is ISO 13485 and ISO 9001 certified. Production and quality control facilities are located in Switzerland. In addition, the Levitronix® R&D team provides third party contract services in cooperation with other research groups.



Headquarter and European Contact

Levitronix GmbH
Technoparkstr. 1
CH-8005 Zurich
Switzerland

Phone +41 44 445 19 13
Fax +41 44 445 19 14
e-Mail sales@levitronix.com

US Contact

Levitronix Technologies LLC
45 First Avenue
Waltham, Massachusetts 02451
USA

Phone +1 781 622 5070
Fax +1 781 622 5090
e-Mail ussales@levitronix.com

Japan Contact

Levitronix Japan K.K.
No. 6 Hata Building,
2-14-3 Kinshi, Sumidaku
Tokyo, 130-0013 Japan

Phone +81 3 5673 5781
Fax +81 3 5673 5782
e-Mail japansales@levitronix.com

Taiwan Contact

Levitronix Taiwan
5F, No. 251, Dong Sec. 1,
Guangming 6th Rd., Chu Pei City,
Hsi-Chu 302, Taiwan, R.O.C

Phone +886 3 657 6209
Fax +886 988 321472
e-Mail asiansales@levitronix.com



www.levitronix.com