



LED LIGHTING

FOR MACHINE VISION INDUSTRY

Design and manufacturing

*Since 1999 next to you
making your vision easier*

2021 PRODUCT GUIDE





► Where to find DCM Sistemas

DCM Sistemas is a company widely recognized for its machine vision illumination systems. Founded in 1999, DCM Sistemas products have enabled machine vision to perform quality controls reliably through optimal lighting to ensure readability. DCM Sistemas is continuously developing new products which are designed with practical, cost-effective technologies. You can find us at:



■ DCM SISTEMES

Pol. Ind. 'El Oliveral'
c/x 46190 - Ribarroja del Turia,
Valencia (SPAIN).

T. (+34) 96 166 65 27

Email: info@dcm sistemas.com
www.dcm sistemas.com

DCM Sistemas deliveries everywhere around the world.

The delivery deadline offered in any related document should be understood always as orientating. Standard lighting systems would be ready for transportation in a maximum period of three days but frequently this period is less than 24h.



► DCM Sistemas products

DCM Sistemas LED lighting systems comply standards described below for guaranteeing you the good quality of our products, which are also classified according to the international protection rating.

■ EC Marking- European Conformity

This is a mandatory conformity mark for products placed on the market in the European Economic Area (EEA). With the CE marking on a product, the manufacturer ensures that the product conforms with the essential requirements of the applicable EC directives.



■ Restriction of Hazardous Substances Directive

This directive restricts the use of six hazardous materials in the manufacture of various types of electronic and electrical equipment. It is closely linked with the Waste Electrical and Electronic Equipment Directive (WEEE) and is part of a legislative initiative to solve the problem of huge amounts of toxic e-waste.



■ Waste Electrical & Electronic Equipment Directive

This symbol indicates that this product shall not be treated as household waste. Instead it shall be handed over to the appropriate collection point for the recycling and recovery of electrical and electronic equipment. This recycling of materials will help to conserve natural resources.



■ International Protection Rating

IP Code classifies and rates the degrees of protection provided against the intrusion of solid objects (including body parts like hands and fingers), dust, accidental contact, and water in mechanical casings and with electrical enclosures.





INTRODUCTION	2		
ABOUT DCM SISTEMES	2		
IMAGING & DCM SISTEMES	4		
TYPES OF LIGHTING	7		
OPERATING MODES & TYPES OF LAMPS	8		
ILLUMINATION OVERVIEW	10		
HOW TO USE THIS CATALOGUE	12		
iBLUEDRIVE TECHNOLOGY	14		
iBLUEDRIVE TECHNOLOGY	16		
LIGHTING SYSTEMS	18		
ALB SERIES - Direct High-Powered ringlights	20		
ALD SERIES - Direct ringlights	22		
ALS SERIES - Diffuse ringlights	24		
ALU SERIES - Ultra diffuse ringlights	26		
ALW SERIES - Low angle ultra-diffuse ringlights	28		
AUB SERIES - Borescopic diffuse ringlights	30		
BKC SERIES - Cylindrical backlights	32		
BKL SERIES - Area backlights	34		
BKM SERIES - Large area backlights	40		
BKN SERIES - Linear backlights	42		
DKL SERIES - Darkfields lights	44		
DOL SERIES - Linear dome lights	46		
DOM SERIES - Dome lights	48		
DTL SERIES - Transmitted dome lights	52		
PLA SERIES - High-Powered linear lights projectors	54		
PLC SERIES - Compact linear lights projectors	56		
PLD SERIES - Direct linear lights projectors	60		
PLU SERIES - Diffuse linear lights projectors	62		
PRA SERIES - Compact coaxial spot lighting	64		
PRC SERIES - Compact high-powered lights projectors	66		
PRD SERIES - Spot projectors	68		
PRF SERIES - Adjustable focus lens projector	70		
PRH SERIES - High-powered lights projectors	72		
PRK SERIES - Harsh environment washdown HP projectors	74		
		PRL SERIES - Line lights projectors	76
		PRY SERIES - Direct lights projectors	78
		SAC SERIES - Diffuse axial compact lights	80
		SAL SERIES - 90° diffuse axial lights	82
		SAR SERIES - Diffuse ring & 90° axial lights	84
		SAX SERIES - Diffuse axial lights	86
		ACCESSORIES	88
		LIGHTING FILTERS	
		DUST PROTECTION KIT	91
		DARKFIELD CONVERTER	91
		HEAT DISSIPATOR	91
		CABLES	92
		FIXING BRACKETS	95
		LENS FILTER HOLDERS	99
		COLOR TEST LAMP	101
		STROBE AND RGB CONTROLLERS	102
		iBLUEDRIVE TECHNOLOGY	103
		ADDITIONAL INFORMATION	104
		Z1.1 - CONTROL INPUT NPN/PNP for 'type C' lighting systems of DOL, PLC, PRH, PRK series, PRC0604C and PRC0606B.	106
		Z2.1 - iBLUEDRIVE CONTROL INPUT WIRING	107
		Z2.2 - iBLUEDRIVE INLINE	107
		Z2.3 - iBLUEDRIVE ACCESSORIES LEGEND	107
		Z3.1 - ENVIRONMENTAL SPECIFICATIONS	108
		Z3.2 - MODIFIERS LEGEND	108
		Z3.3 - ACCESSORIES LEGEND	108
		Z3.4 - TECHNICAL DRAWINGS LEGEND	108
		Z3.5 - COLOURS & WAVELENGTHS LEGEND	108
		Z3.6 - TYPES OF LIGHTING LEGEND	108
		Z3.7 - TYPES OF LIGHT LEGEND	108
		Z4.1 - CHOOSING THE CORRECT ILLUMINATION	109
		Z5.1 - ACCESSORIES & MODIFIERS OVERVIEW	110

All company and product names contained in this catalogue are trademarks of their respective owners. No part of this catalogue can be reproduced or used in any medium without permission from DCM Sistemas.

DCM Sistemas products are aimed at integrators or end users with some integration expertise. For end users who need a turn-key solution installed, contact us to realise your application.

In the following sections you will find theoretical and technical information about imaging in general or our range of products in particular. If you require extended information, feel free to ask anytime.

Read carefully instructions given apart with each lighting system before using to ensure the correct operation. Product specifications and design are subject to change without prior notice. Examples of workpiece imaging in this catalogue are a guide that may be informative for choosing illumination. Please, check the functions of the systems and requirements when choosing.



► Imaging & DCM Sistemmes

Being constantly intensified the pressure on costs and increased competition, the need to manufacture good quality products rapidly, reliably, economically and without faults, is more important than ever.

Production technologies ever more often extend far beyond the limits of human visual capabilities. This is where machine vision comes in, to recognise objects or situations and make the right decisions accordingly.

Imaging systems open new possibilities in quality assurance that were previously impossible to implement, and gives manufacturers a competitive advantage. DCM Sistemmes is a company involved into design and manufacturing of machine vision led lights, necessities in the industrial application of vision technology.

Vision technology works with images or sequences of images with the objective of manipulating and analysing them, improving quality, restoring images, coding pictures or understanding and interpreting them. Thus vision technology can be applied wherever the images are generated and need to be analysed, in a wide range of different applications and industries. DCM Sistemmes looks for and develops lighting solutions for those applications that standard lighting systems are not able to solve.

Taking good pictures is fundamental in artificial vision processes. Choosing the appropriate lighting system could determinate the success or failure of an application. Precision, repeatability, stability, consumption or space are some advantages of DCM Sistemmes led lighting systems.

Our objective is to provide something more than just a led lighting system but a tested and validated solution optimised to solve your imaging task. Is that the reason why our product portfolio is constantly expanding.

Our staff is made up of multidisciplinary personnel, highly qualified, with broad experience in this sector. Based on customer requirements, DCM Sistemmes makes a detailed study of lighting, which is always strictly confidential. The analysis and check outs made by our lighting engineers, provide the ideal solution for every situation. After that, our client obtains this detailed study of the ideal lighting and even sample images for processing with its own vision tools.

Therefore, we encourage you to call our engineers to discuss your needs, so that we may work with you in creating your best imaging solution.



► Our services

DCM Sistemmes aims to offer industry leading service. For that reason, our extensive technical knowledge is available to our customers and extends to provide advice before and after purchase, feasibility studies, competent and knowledgeable support. Our commitment includes the following:

■ TECHNICAL SUPPORT

DCM Sistemmes technical department provides assistance after purchase, in order to help our clients solve specific problems with a product. Our freely available technical support may be delivered over the telephone or online by e-mail.

■ CUSTOMIZED SERVICE

DCM Sistemmes offers the possibility of manufacturing customized designs for adapting its lighting systems to our clients needs, in case any of the standard products fits their application. Parameters such as form, size, wavelength or light intensity can be re-designed to obtain the most suitable lighting system for each case, in a short time and competitive pricing.

■ FREE LIGHTING STUDIES

Our lighting engineers are always ready to evaluate samples and make recommendations on the best approach to solve an application. Please, contact our technical staff for more information.

■ LOANING PROGRAM

DCM Sistemmes lends freely for testing its standard products during a 15 days period without any obligation, so that its clients could test and confirm that are the most suitable ones.

■ e-NEWS

DCM Sistemmes is continuously developing and expanding its product portfolio, so that our marketing assistants send periodically to our customers a newsletter with the latest updates and details of version upgrades. You can unsubscribe at any time and your e-mail address will be removed from our mailing list. To subscribe, please register as a new user on our website.

■ SPECIAL DEALS

DCM Sistemmes' goal is to be your long-term led lighting system supplier, and in return, we offer special conditions, additional services and discounts to those customers who continue to rely on our services.

► DCM Sistemmes presence

DCM Sistemmes attends annually to the most important trade fair for machine vision at Messe Stuttgart. Here we present all our novelties of the year and the future projects in progress.

DCM Sistemmes is convinced of the importance of keeping directly in touch with its clients and other users of machine vision.

It is a good opportunity for you to know us and our products.



► Applications

Imaging technology is a cost-effective way to implement automatic quality assurance and control and is used in many different areas of application. Vision allows 100% monitoring and therefore strengthens the competitive edge of those companies that use it, even at high speeds and with stringent conditions. Some of the applications and markets we serve are the following. Consult others:

- Food processing & inspection
- Electronics manufacturing
- Automotive inspection
- Product inspection & measurement
- Print & packaging
- Factory automation & robotics

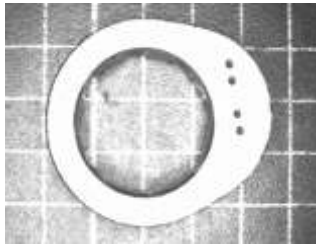

► Illumination for machine vision systems

Illumination is the most important part of an imaging system and its importance is often underestimated in many vision applications.

Lighting conditions need to be optimised because cameras are much less versatile than the human eye and, that way, they can detect objects that the human eye can see in uncontrolled conditions.

Cameras see the light reflected from the objects. By controlling the illumination, we also control how objects appear to the camera. For example, light is reflected differently from a coin than from a flat white label and thus different lighting techniques are required.

Optimising the lighting can often eliminate the need for costly and time-consuming image manipulation. Choosing an inappropriate illumination could determine if a system works reliably or does not.

► Factors affecting lighting

It is important to control illumination because it reveals the particular defects or features. The main factors affecting lighting are:

■ ANGLE OF ILLUMINATION (Types of lighting, page 7)

The angle at which the light falls on the object (lighting zones), is probably the most important factor of illumination. The angle of incidence is determined by the plane of the camera.

'Front lighting' and 'backlighting' are the two principal lighting areas. In the first one, the light originates from the same side as the camera. In the second one, the light is situated behind the object.

'Bright field' refers to any illumination where the light rays from the source could be reflected directly into the lens, which will depend on its angle of view. 'Dark field' illumination refers to light that would not enter the lens when reflected.

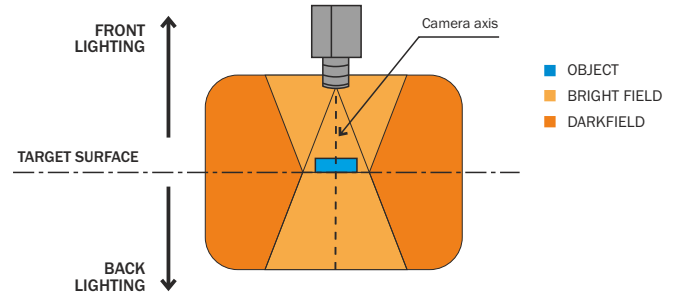

■ WAVELENGTH OF LIGHT

Colour of the light that illuminates the object. Apart from the visible spectrum, ultraviolet and infra-red light can reveal specific features on or in the work piece to be inspected.

■ LIGHT TYPE

The quality of light is determined by its structure. For illumination to be useful it needs to light the scene as evenly as possible, that makes the image analysis be easier and faster.

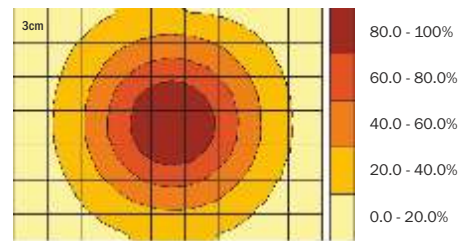

DCM Sistemas provide distribution graphs to show how our lights perform and to enable a reasoned choice between different types of light.

Direct light has an uninterrupted trajectory between the source and the target. **Indirect light** uses a translucent diffuser which softens and disperses the illumination. The difference between diffuse and ultra-diffuse light is the lighting source. While diffuse light uses a not uniform lighting source, the ultra-diffuse one is completely homogeneous, creating a more even illumination, ideal for brightnesses.

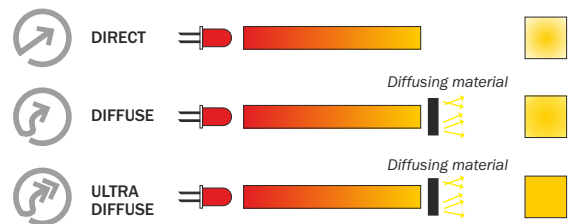

■ SURFACE CONSIDERATIONS

The way that the illumination interacts with the target surface is of great importance in obtaining a high quality image.

■ OPERATING MODE

Illumination usually needs to be controlled in some way. Lights can work in a continuous mode or can be strobed or powered on, the intensity can be raised or lowered. Multiple illumination options are allowed in our lamps.

(extended information at operating modes section on page 8)



► The colour of light

There are two different color systems: The '**subtractive**' is the system which, combining all three pigment colors, the result is a dark color almost black. This system is typical of printed colors, inks, etc. On the other hand, the '**additive**' system is that which, combining all primary colors (RGB), the result is a light color or white, characteristic of focus and screens, etc. **Light is additive and overlapping all colors results in white light.**

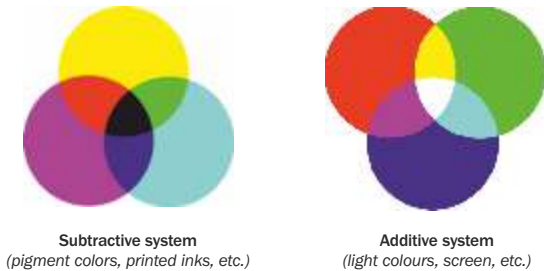

There are many universal classifications of color spaces but, when referring to artificial vision, the main mode is the RGB, a mix of **red**, **green** and **blue** that constitutes the primary colors that are used by cameras, PCs and screens and, which in combination, can create almost any colour in the visible spectrum.

When light falls into an item, its surface absorbs some wavelengths and reflects other. The reflected wavelengths are those which the human eye captures and interprets as different colors, according to the correspondent wavelength. The white light is the overlapping of all colors of visible spectrum.

The colour cameras emulate the function of human eye by using a matrix composed of sensors which capture different ranges of the visible spectrum. Usually, they use three ranges, **red (R)**, **green (G)** and **blue (B)**. Later, they group all information obtained by the sensor in one pixel with three values **Red-Green-Blue**.

Illumination for machine vision uses all this to its advantage in order to reveal certain characteristics about a particular object. The vision is then, the ability to detect light and interpret it.

Of the entire electromagnetic spectrum, the visible part to the human eye is very small and comprises wavelengths between 380nm and 760nm or so, although it may vary depending on the person.

Besides the visible spectrum, is important to consider the ultraviolet light and infrared light, because they can be useful for some other characteristics of the object of inspection. Cameras have a different spectral response than it has the human eye and therefore, they are sensitive to them.

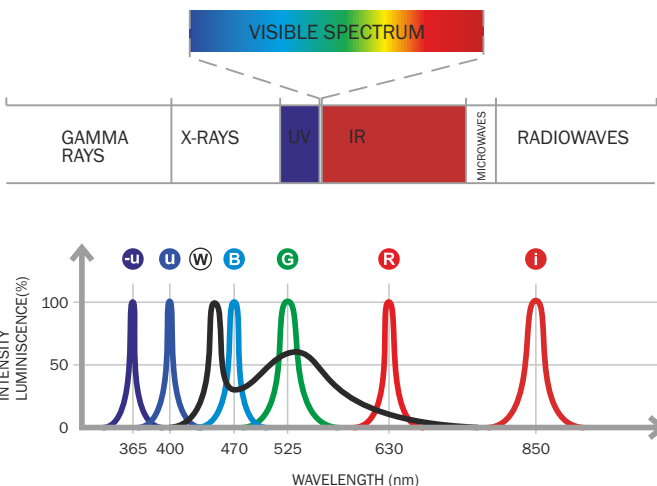

icon	WaveLength	Colour	Type of light	Code
-U	365nm	UV-	Monochromatic	-365
U	400nm	UV	Monochromatic	-400
B	470nm	BLUE	Monochromatic	-470
G	525nm	GREEN	Monochromatic	-525
R	630nm	RED	Monochromatic	-630
i	850nm	IR	Monochromatic	-850
W		WHITE	White	-W00
		RGB	RGB	-RGB

► Monochromatic light

The monochromatic light is the one that has a single wavelength corresponding to each colour. It is normally used in monochrome cameras. Very useful to highlight some specific features, since each color provides better visibility in certain aspects or by contrast, since all opposite colors are absorbed.



DCM Sistemas logo illuminated with white light.



DCM Sistemas logo illuminated with red light (R).



DCM Sistemas logo illuminated with green light (G).



DCM Sistemas logo illuminated with blue light (B).

The ultraviolet and infrared light, although outside the visible spectrum, they are both very useful to inspect materials or contrasts of colour differences not very apparent, since this light is based on differences in composition planes.



Ultraviolet light is generally used on surfaces that react to this light by returning a longer wavelength light than it is UV, which is called fluorescence and that is what the camera captures. (See picture)

► RGB light

The RGB color model is based on **additive synthesis**. With this synthesis it is possible to represent a color by admixture of the three primary light colors **red**, **green** and **blue**. Usually used in monochrome cameras, to change the contrasts between colors, or RGB cameras to generate structured light colored, very useful in cases of weld inspection or to adjust colour temperatures.

► White light















Differently from monochromatic light, the white light is formed by many components and it is the result of the overlapping of all colors from visible spectrum. Usually used with RGB cameras.



Always we use a color camera, light should be white or RGB.



► Types of lighting

Icon	Type of lighting	Description	Use sample
	RADIAL	<ul style="list-style-type: none"> ■ Perimeter-based, high angle of incidence. ■ Softens textures and surface detail, reduces shadows. ■ Ideal for long working distances 	
	LOW-ANGLE <i>'Dark-field' light effect</i>	<ul style="list-style-type: none"> ■ Perimeter or uni-directional, low angle of incidence. ■ Highlights surface detail, topography or edges. ■ Requires short working distances. 	
	BACK-LIGHT	<ul style="list-style-type: none"> ■ Sample located between light and camera. ■ Instant sample vs. background contrast or transmission through samples. ■ Obtain accuracy for gauging applications or edge detection. 	
	DOME <i>'Cloudy day' light effect</i>	<ul style="list-style-type: none"> ■ Multiple angles of incidence. ■ Achieves uniform, shadowless illumination, softening contrast. ■ Effective for curved, reflective surface inspection. 	
	BRIGHT FIELD	<ul style="list-style-type: none"> ■ Directional, high angle of incidence. ■ Camera and light source placed at same angle to sample surface. ■ Highlights cracks and deformities on flat and bright surfaces. 	
	PROJECTOR	<ul style="list-style-type: none"> ■ Directional, and can be aimed at high or low angle of incidence ■ Angle of incidence determines degree of feature prominence. 	
	AXIAL	<ul style="list-style-type: none"> ■ Co-axial with the camera's optical axis ■ Accentuates changes in sample angles and heights ■ Optimal for inspecting smooth shiny surfaces such as polished metal. 	

How light interacts with object diagram key:

DCM Systemes light source
 Object to be inspected
 Light incident on the object
 Light from the object



► **DCM Sistemess operating modes**

Most illumination needs to be controlled in some way, whether it be simply turning the light on and off, or controlling how intense the illumination is.

DCM Sistemess lighting systems are classified in four types according to their working specifications, which helps to recognise which kind of control is needed:

- Continuous (Type C). No control needed.
- Powered (Type P)
- Strobe (Type S)
- Intelligent (Type i). iBlueDrive technology.

Intelligent mode corresponds to iBlueDrive technology, a new generation of lighting systems that integrate the strobe controller inside, so that operate in all three working modes swithcing automatically.

► **Continuous**

It has no operation time limitation (Ton max.) nor duty cycle limitation (D max.). Used in linear cameras or applications that do not need intensive illumination and require continuous inspection with long exposure times.

Corresponds to DCM Sistemess Type C lamps.

Continuous

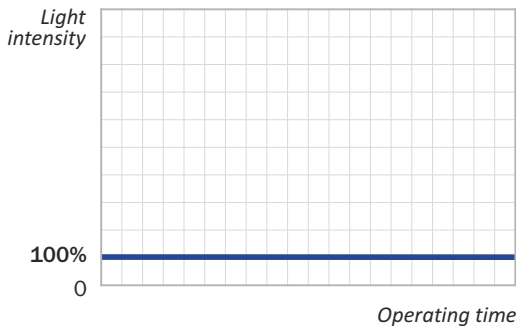

Continuous mode	
Advantages	Easy installation
Disadvantages	Higher consumption, lower illumination

► **Powered**

This mode operates the same manner as the continuous mode does, but the intensity is higher and, consequently, to ensure operation, the switching on/off by an external commutator is necessary.

Corresponds to DCM Sistemess Type P lamps.

Powered

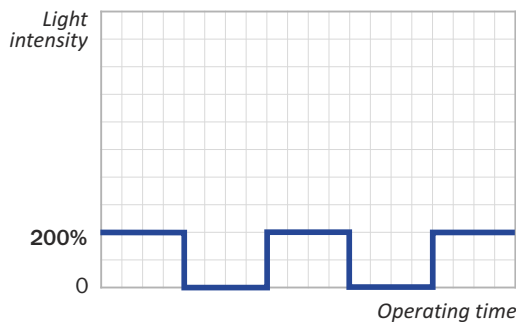

Generally used in inspections that can have long integration times, those that do not require continuous inspection, for example, depalletizing applications or not in-line assembly verification.

Powered mode	
Advantages	Higher power, lower consumption and longer lifespan with easy control and no pricing increase.
Disadvantages	They need a control of switching on/off and have less power than strobe lamps.

► **Strobe**

Strobing is the technique of activating a light for a short period of time in order to, among other, the followings:

■ **HIGHER INTENSITY**

More current pass through the leds than it is allowed in continuous operation. The output intensity increases considerably, but it can only be sustained over a short period of time, because if this were done constantly, the light would run hotter, reducing its life.



■ **PROLONGING THE LIFE OF THE LIGHT**

All light source has a finite life span which can be dramatically extended by activated them only when required. Leds can be switched on and off very rapidly with little time delay or energy loss.

■ **FREEZING MOTION**

This technique is often used in vision to capture images of objects moving past the camera at speeds that would normally cause motion blur. Strobing needs to be synchronised with the objects to be inspected so that the camera is triggered at the same moment as the pulse of light.

■ **INTENSITY CONTROL**

Sometimes, for better meeting the requirements of the application we need to create the optimum lighting conditions by adjusting or balancing the intensity of the illumination, and this will usually involve the use of a lighting controller. There is a range of situations where this may be useful.

This mode consists of short trigger pulses at high rate with high intensity.

Used in continuous inspections with short integration times at high speeds, such as an inspection in-line production or a high speed inspection which requires a large amount of illumination.

Corresponds to DCM Sistemess Type S lamps.

Strobe

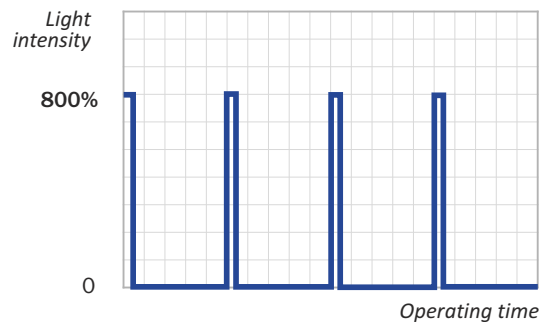



Strobe mode

Advantages	Higher intensity of illumination, lower consumption. Longest lifespan.
Disadvantages	Requires an strobe controller for configuration.

DCM Sistemess' powered mode (**Type P lamps**) is the step between the continuous mode and strobe. This mode could be defined as a strobe illumination because has the same advantages and requirements with less control needed.

► **Intelligent (iBlueDrive)**

Lighting systems with iBlueDrive technology detect the input signal and operate in the appropriate mode according to the control signal. These systems also switch from continuous to strobe automatically.

Corresponds to DCM Sistemess *Type i lamps*.

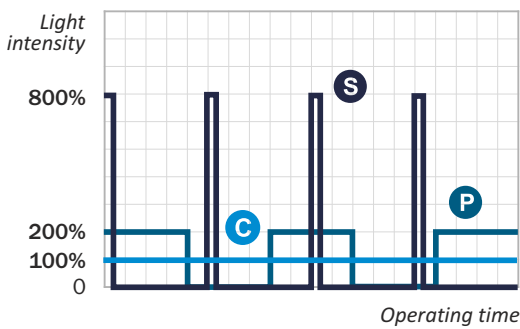

Intelligent mode

Advantages	No needs strobe controller. Easy, powerful, robust and versatile. Three modes in one.
Disadvantages	Price slightly higher than its equivalent in continuous mode (Type C).

Extended information of iBlueDrive technology on page 16

► **Be aware of...**

DCM Sistemess lighting systems are identified with the letter of their operating mode at the end of the order reference.

Excluding iBlueDrive lighting systems which are capable to operate in various modes, our lamps are firstly designed to work in a particular mode, but they can work in others if adapting their working specifications to more restrictive ones. This means, for example, that a Type C lamp (continuous operating mode) could be strobed or powered as the working specifications of these modes remain within its operating range. The same way, a Type P lamp (powered operating mode) could be strobed by limiting the operating time and the duty cycle.

The inverse adaptation would also be possible by lowering the supply voltage and therefore the lighting systems power for adapting the average power consumption to the maximum duty cycle allowed. Continuing with the previous example, a Type P lamp (powered operating mode) could also work as a continuous if the power is lowered to ½.

DCM Sistemess lighting systems have a strong versatility and are able to work in many environments. Consult our technical engineers for extended information or doubts about the operating modes.

► **Types of DCM Sistemess lighting systems**

	C	P	S	i
Type of lamp	TYPE C	TYPE P	TYPE S	TYPE i
Control type	None	Externat switch for switching ON/OFF	Strobe controller (VST or VSC Series recommended)	No needed <i>An advanced adjusting of operating parameters requires iBlueDrive Box</i>
Max. Operating time	unlimited	60s	2ms	Automatic
Max. Duty cycle	1	1/2	1/20	Automatic
Do they operate in continuous mode?	YES	YES, reducing ½ the power intensity	NO	YES
Do they operate in powered mode?	YES, maintaining the power intensity	YES	NO	YES
Do they operate in strobe mode?	YES, maintaining the power intensity	YES, maintaining the power intensity	YES	YES
Do they operate in intelligent mode?	NO	NO	NO	YES
Order reference	Add C at the end of the order reference	Add P at the end of the order reference	Add S at the end of the order reference	Add i at the end of the order reference
Example	ALD0606A-630 C	ALD0606A-630 P	ALD0606A-630 S	ALD0606A-630 i



► Parameters for choosing lighting illumination

DCM Sistemas has a wide range of standard products. Starting from the type of lighting (angle of illumination) and the type of light, here is a complete classification of DCM Sistemas products and all parameters involved when selecting.

There are considerations that give us useful information to determine which type of illumination is best for a particular job, making this duty easier. This will determine which light is best suited to an application.

► 1. Type of lighting

	RADIAL	LOW ANGLE	BACK-LIGHT	DOME
How the light falls on the object (angles of illumination) <i>More information at page 07</i>				

► 2. Type of light

DIRECT Reaches directly the object producing maximum contrast.	 ALD SERIES	 DKL SERIES		■ Combination of two independent lighting types that can work together or separately.
DIFFUSE Softens and disperses the light, illuminating evenly.	 ALS SERIES	 SAR SERIES		
ULTRA-DIFFUSE Very diffuse illumination, for even more reflecting surfaces.	 ALU SERIES	 AUB SERIES	 ALW SERIES	
			 BKL SERIES	
			 BKM SERIES	
			 BKN SERIES	
			 BKC SERIES	
			 DTL SERIES	
			 DOL SERIES	
			 DOM SERIES	

Main type of lighting (angle of illumination) and light type of each series. Other possibilities allowed by adding accessories or modifiers. Consult on each series' datasheet where you could find extended information.

► 3. Colour (wavelength)

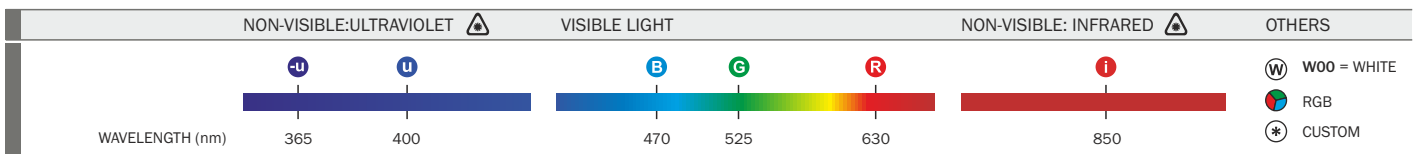

► 4. Operating modes

	CONTINUOUS	POWERED	STROBE	INTELLIGENT (iBLUE)
Type of lamp	Type C	Type P	Type S	Type i
Maximum time ON (Ton max)	∞	60s	2ms	Automatic
Maximum duty cycle (Dmax)	1	1/2	1/20	Automatic
Light intensity	100%	200%	800%	100% to 800%
Extended information at page 8.		Prevent thermal limitations. Switching ON/OFF is necessary. 	Used with a strobe controller. 	Detect the input signal and operate in the appropriate mode according to the control signal. These systems also switch from continuous to strobe automatically.



► Lighting environment

DCM Sistemas lighting systems have been designed to operate over a long period of time with a minimum of maintenance. They are perfectly adapted to industrial environments and all of them comply with standards, offering ecofriendly and safe products. Continuous satisfactory operation depends upon care and regular cleaning.



■ **Lighting combination series**
Combination of two independent lighting types that can work together or separately.

BRIGHT-FIELD	PROJECTOR	AXIAL

► 5. Modifiers

Prior to manufacturing optional modifications in standard lighting systems. They **must** be indicated at the end of the product's order reference.

Description	Code
Narrow angle of emission	/AN
Medium angle of emission (by default)	/AM
Wide angle of emission	/AW
Oval angle of emission = 23-24° (x) / 17-18° (y)	/AO
Diffuse emission	/AD
Polarizer filter	/FPL
Diffuser filter	/FDR
Backlight hole of 42mm	/H
Backlight hole of 65mm	/H1
Dome hole of 46mm	/CC1
Dome hole of 40mm	/CC2
IP Rating = IPxx = IP65 / IP67	/65 / 67
PNP input model	/P
50mm focal Length	/F1
150mm focal Length	/F2
Infinite focal Length	/F3
Lighting by x sectors = xS = 2S / 4S	/2S / 4S

► 6. Accessories

Supplementary complements for DCM Sistemas led lighting systems.

Description	Series
Power cable/s	VCB, VCC, VCD
Interconnection & programming cable/s	VCU, VCL
Strobe and RGB controller/s	VST, VSC
Polarizer filter	VPF, VPC
Diffuser filter	VDF
Collimator filter on x/y/xy axis	VCF
Darkfield converter	VRF
Protector filter	VPT
Fixing bracket	VBA, VBB, VBC
Dissipator	VHD
iBlueDrive technology accessories	VTA



► Product datasheet (example)

TYPE OF LIGHTING

Identifies how the light usually falls into the target. It is the most common angle of incidence, but other uses can also be possible.

Lighting combinations will be represented with the two icons appearing together in the first place.

More information of lighting types at page 07.

TYPE OF LIGHT

Identify the type of light of the series. Three possibilities.

ACCESSORIES & MODIFIERS

Identified with an icon. Consult the iconography legend for extended information.



Indicates if iBlueDrive technology is allowed or not, which modality is used and how it is connected or which accessories are available.

Extended information of iBlueDrive Technology at page 16.

NOTES

Additional comments to give you extra information or to help you understand some aspects of the datasheet.

SERIES' NAME & DESCRIPTION

ADDITIONAL INFORMATION

Extended information. You might find images of use samples, brightness distribution or light intensity graphs.

SERIES' NAME & DESCRIPTION

DATASHEET VERSION

LED LIGHTING SYSTEMS

BKL SERIES Area back-lights (1/3) - BKL9030A to BKL1007B

Posterior diffuse lighting system usually used to measure precisely or emphasize light dark differences by contrast that allows to have good images of sport's shape.

Are used to inspect profiles and edges also used for bright lights creation.

BKL21.01

Technical specifications¹

Lighting model	BKL9030A	BKL9030B	BKL9030A	BKL9030B	BKL9030A	BKL9030B	
Dimensions	40x30x20	52x50x20	62x50x20	75x50x20	86x77x20	98x107x20	
Active surface	30x30	40x50	50x50	50x70	70x70	70x100	
Weight	49g	65g	95g	140g	198g	255g	
IP rating	IP60	IP60	IP60	IP60	IP60	IP60	
Mounting holes	Ø3MM T6	Ø4MM T6	Ø4MM T6	Ø5MM T6	Ø5MM T6	Ø5MM T6	
Connection	2P male chassis connector 1x 250Vrms, P/N 1 = +24V, P/N 2 = 0V	2P male chassis connector 1x 250Vrms, P/N 1 = +24V, P/N 2 = 0V	2P male chassis connector 1x 250Vrms, P/N 1 = +24V, P/N 2 = 0V	2P male chassis connector 1x 250Vrms, P/N 1 = +24V, P/N 2 = 0V	2P male chassis connector 1x 250Vrms, P/N 1 = +24V, P/N 2 = 0V	2P male chassis connector 1x 250Vrms, P/N 1 = +24V, P/N 2 = 0V	2P male chassis connector 1x 250Vrms, P/N 1 = +24V, P/N 2 = 0V
Power cable (non-included)	VCB Series	VCB Series	VCB Series	VCB Series	VCB Series	VCB Series	
Accessories ²	NO	NO	NO	NO	NO	NO	
iBlueDrive tech.	Index	Index	Index	Index	Index	Index	
iBlueDrive connection	3P serial male 250V connector 1x 250Vrms, P/N 1 = +24V, P/N 2 = 0V, P/N 3 = Control ³	3P serial male 250V connector 1x 250Vrms, P/N 1 = +24V, P/N 2 = 0V, P/N 3 = Control ³	3P serial male 250V connector 1x 250Vrms, P/N 1 = +24V, P/N 2 = 0V, P/N 3 = Control ³	3P serial male 250V connector 1x 250Vrms, P/N 1 = +24V, P/N 2 = 0V, P/N 3 = Control ³	3P serial male 250V connector 1x 250Vrms, P/N 1 = +24V, P/N 2 = 0V, P/N 3 = Control ³	3P serial male 250V connector 1x 250Vrms, P/N 1 = +24V, P/N 2 = 0V, P/N 3 = Control ³	
iBlueDrive power cable (non-included)	VCC Series	VCC Series	VCC Series	VCC Series	VCC Series	VCC Series	
iBlueDrive accessories ²	① ② ③	① ② ③	① ② ③	① ② ③	① ② ③	① ② ③	

Instantaneous consumption⁴ (max.) *WT

Lighting model	BKL9030A	BKL9030B	BKL9030A	BKL9030B	BKL9030A	BKL9030B
TYPE C	1.4W	2.4W	3.1W	4.3W	6.4W	7.9W
24VDC	1.3W	2.3W	3.1W	2.9W	4.2W	4.8W
1.1W	1.9W	3.8W	2.4W	3.1W	3.5W	6.3W
1.3W	2.0W	5.3W	2.4W	3.8W	4.8W	8.0W
1.3W	2.0W	5.3W	2.4W	3.8W	4.8W	8.0W
1.6W	2W	3.1W	4.3W	6.4W	7.9W	8.0W

TYPE P *No Type P standard LED lighting systems in this series.

Lighting model	350mA/4.4W	165mA/4.8W	750mA/1.7W	970mA/2.9W	1430mA/3.6W	1320mA/3.2W
TYPE S	350mA/4.4W	165mA/4.8W	750mA/1.7W	970mA/2.9W	1430mA/3.6W	1320mA/3.2W
Dimmer 50% Typ max ⁵ 20ms	270mA/3.2W	440mA/3.9W	750mA/1.7W	970mA/2.9W	1430mA/3.6W	1320mA/3.2W
250mA/3.2W	550mA/3.9W	750mA/1.7W	970mA/2.9W	1430mA/3.6W	1320mA/3.2W	
350mA/4.4W	220mA/4.4W	750mA/1.7W	970mA/2.9W	1430mA/3.6W	1320mA/3.2W	
350mA/4.4W	550mA/4.4W	750mA/1.7W	970mA/2.9W	1430mA/3.6W	1320mA/3.2W	
N/A	600mA/4.4W channel	800mA/4.4W channel	800mA/4.4W channel	1200mA/4.2W channel	1800mA/4.2W channel	1800mA/4.2W channel
TYPE P	2.4W(1.0W/1.2W)	3.9W(1.7W/1.9W)	4.3W(2.0W/2.0W)	5.8W(2.7W/4.4W)	6.2W(2.9W/3.6W)	7.7W(4.0W/4.2W)
3.4W(1.0W/1.2W)	5.2W(1.7W/3.9W)	6.2W(2.0W/3.9W)	8.4W(2.7W/5.2W)	12.9W(3.7W/4.4W)	13.9W(4.0W/4.2W)	
1.9W(1.2W/1.4W)	4.1W(2.4W/3.9W)	6.2W(2.0W/4.9W)	4.2W(2.4W/3.9W)	6.2W(2.0W/4.2W)	7.7W(4.0W/4.2W)	
1.9W(1.2W/1.4W)	4.1W(2.4W/3.9W)	6.2W(2.0W/4.9W)	4.1W(2.4W/3.9W)	6.2W(2.0W/4.2W)	7.7W(4.0W/4.2W)	
2.4W(1.0W/1.2W)	3.9W(1.7W/3.9W)	4.3W(2.0W/4.9W)	5.8W(2.7W/4.4W)	6.2W(2.9W/4.2W)	7.7W(4.0W/4.2W)	

*Wt = Not available. *C = Continuous

(1) Environmental specifications and iconography aligned in additional annex Z1.1 and Z2 respectively.
(2) Prior to manufacturing optional modifications in standard lighting systems. Please, consult the code before ordering (additional annex Z2.2).
(3) Accessories are non-included. More information in accessories section.
(4) iBlueDrive control input wiring specifications in additional annex Z1.3.
(5) Max. in real consumption table only to be used as guide. To refer to real values, please, consult product label when purchasing.
(6) Values of maximum instantaneous consumption of Type P lighting systems in Powered mode (Strobe mode / Continuous mode).

30 *ORDER REFERENCE: Lighting model + WT / MODIFIERS

DCM SYSTEMES

zones in gray are parts of the order ref.

LIGHTING MODEL

-WT (Wavelength & Type of lamp)

How to order?

MAX. INSTANTANEOUS CONSUMPTION

In continuous (C) and powered (P) lamps this is the maximum consumption average during the ON state. In strobed lamps (S) is the maximum allowed current.

In iBlueDrive (i) these are the three values in Powered mode [Strobe mode / Continuous mode]

More information of operating modes at page 08.

BKL SERIES - Area backlights

BKL SERIES

BKL14.01

IDENTIFICATION ICON

Identifies which type of information you will find in that section

- THEORETICAL INFORMATION
- LED LIGHTING SYSTEMS
- ACCESSORIES
- ADDITIONAL INFORMATION

TECHNICAL DRAWINGS

Example of BKL captured image

Brightness distribution of DCMS005A-430CB-250W

DCMS005A-430CB light intensity

©2021 DCM SYSTEMES™. All rights reserved.
Product specifications and design are subject to change without prior notice. www.dcmsistemas.com

31



► **How to order standard lighting systems. Order reference**

Composed by two or three parts. The two main parts are marked in each product datasheet with gray frames to identify them easily. Only add the third when ordering modifiers or when the lighting system has an aperture angle .

(example): ALD0707A-630C/FPL

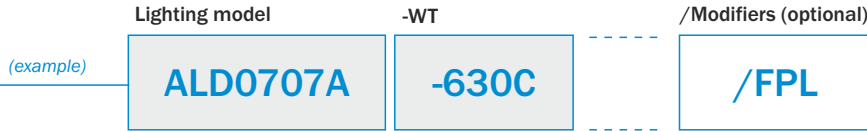

Abbreviation for **Wavelength (W) & Type of lamp (T)**
(classified according to the operating modes. Page 8).

How do I know which products can add modifiers?

It is indicated with their icons at each product datasheet or in accessories & modifiers overview table in additional annex, Z4.1.

The specific code for adding it to the order reference is on the table below, in additional annex, Z2.1 and Z4.1. or at illumination overview section (page 12 always preceded by '/').

► **Iconography**

In this catalogue you will find lots of icons referring to specific lighting modes, type of light, accessories or modifiers, in order to identify them easily. Here is a quick overview of icons' meaning. More information in their sections.

■ LIGHTING TYPES (extended information at page 7)

icon	Description
	Radial lighting
	'Darkfield' lighting effect. Low angle illumination
	Backlight illumination
	'Cloudy day' lighting effect
	'Bright field' lighting effect
	Projector lighting
	Axial lighting

■ LIGHT TYPES (extended information at page 5)

icon	Description
	Direct light
	Diffuse light
	Ultra-diffuse light

■ ACCESSORIES (extended information in accessories section)

icon	Description	Serie
	Power cable/s	VCB, VCC, VCD Series
	Other cable/s	VCU, VCL
	Strobe and RGB controller/s	VST, VSC Series
	Polarizer filter	VPF, VPC
	Diffuser filter	VDF
	Collimator filter on x axis	VCFx
	Collimator filter on y axis	VCFy
	Collimator filter on xy axis	VCFxy
	Darkfield converter	VRF
	Protector filter	VPT
	Fixing bracket	VBA, VBB, VBC Series
	Dissipator	VHD
	iBlueDrive Box, iBlueDrive USB	VTA0005A, VTA0007A
	iBlueDrive optocoupler	VTA0020A
	iBlueDrive potentiometer	VTA0030B

■ MODIFIERS

icon	Description	Code
	Narrow angle of emission	/AN
	Medium angle of emission (by default)	/AM
	Wide angle of emission	/AW
	Oval angle of emission = 23-24° (x) / 17-18° (y)	/AO
	Diffuse emission	/AD
	Polarizer filter	/FPL
	Diffuser filter	/FDR
	Backlight hole of 42mm	/H
	Backlight hole of 65mm	/H1
	Dome hole of 46mm	/CC1
	Dome hole of 40mm	/CC2
	IP Rating = IPxx = IP65 / IP67	/65 /67
	PNP input model	/P
	50mm focal Length	/F1
	150mm focal Length	/F2
	Infinite focal Length	/F3
	Lighting by x sectors = xS = 2S / 4S	/2S /4S

iBLUEDRIVE



iBLUEDRIVETECNOLOGY



DCM
SISTEMES

► What is iBlueDrive technology?

iBlueDrive® is a technology developed by DCM Sistemas to ease the use of advanced LED lighting systems for machine vision. iBlueDrive® devices allows the user to work in strobe mode almost as easily as in continuous mode. Roughly, it consists of a lighting device with an intelligent built-in microstrobe controller. Only a 3-terminal cable is needed to power and control the lighting.



Some of the main features of iBlueDrive devices are:

- Strobe, powered and continuous working modes in one lamp.
- Direct connection to camera or trigger signal.
- Automatic NPN or PNP detection.
- No configuration needed for start-up.
- Shutter speed preset to up to 47 pulses per second (pps). Configurable up to 5000 pps.
- Protected against reverse voltages, ESD and overheating.
- Anodized aluminum frame.
- Online and offline setup.
- Bidirectional communication for advance configuration through our free iBlueDrive® Control Manager Software: output power, pulse width, delays, bulk trigger...
- Updatable firmware.

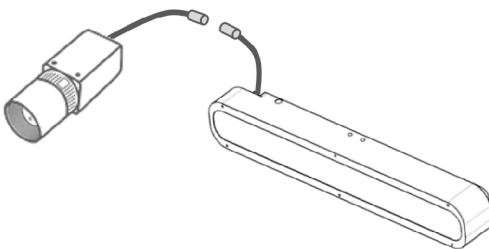

► Just Plug and Play

iBlueDrive technology operates with a new intelligent working 'i-mode', which allows automatic switching between continuous, powered and strobe working modes.

OPERATION MODE	OUTPUT POWER	SIGN VALUE	'ON' TIME
Continuous	100%	Fixed	Indefinitely
Powered	200% ¹	Triggered (PNP, NPN, TTL)	Up to 16 seconds
Strobe	600% ¹	Triggered (PNP, NPN, TTL)	Up to 20 milliseconds ²

(1) Mean value. Real output may vary between models. Please check the particular model datasheet

iBlueDrive lights have only a single multifunctional control terminal, whether they are monochrome, RGBs or multisector device.

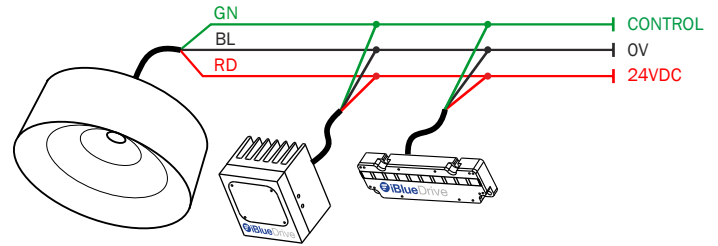

Connection can be done directly to the camera or to the trigger signal such as photocell, inductive sensor, automaton output, etc.

It is possible to use either PNP and NPN trigger signals to control the light. The device will automatically detect which type of signal you are using so no pre-setting is needed.

► More Power. More Light

Lighting systems with iBlueDrive technology set its maximum output power according to the operating mode, no matter if it is strobe, powered or continuous mode, being unnecessary to configure or change anything in the device.

Thanks to its revolutionary design it can output up to 600% power than in continuous mode when working in strobe mode.

► Advanced Configuration

The iBlueDrive lighting systems include all the functionalities of an advanced strobe controller. However, no pre-setting is required to start using the light. Factory presets fit most applications needs. If advanced settings are needed it is possible to configure the light online, this is, keeping it connected to the application. You can connect and control up to 20 devices at a time using our iBlueDrive Box, a hardware interface that connects the iBlueDrive lights to the PC.

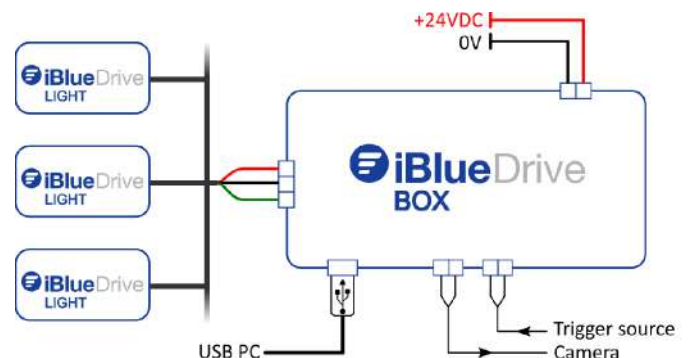

Using the free iBlueDrive Control Manager software you will be able to change any setting of the lights as pulse width, output power of the three modes, other timing parameters and more. Also, you can back up a configuration and restore it later.

The software also gives real time information as voltage supply, device temperature and state and current power output.

iBlueDrive technology is constantly evolving and you can upgrade your devices to benefit the new features easily.

► Integrating iBlueDrive lights in your system

Sometimes it is useful to have access to the light configuration through the main control panel. APIs has been developed in both Python and C# to simplify the integration of the iBlueDrive lights into your system. They are released under MIT License so it is possible to include them in proprietary software.



► Robust and Reliable

Thanks to the integrated microcontroller the device is continuously monitored protecting it against misuse and providing information about its state, making it ideal for the most demanding applications.

In addition, iBlueDrive devices are ESD protected and feature a configurable digital input filter that is useful to ignore unintended triggers due to voltages spikes in electromagnetic noisy environments.

► Fast Applications? No Worries!

iBlueDrive devices can be triggered up to 5.000 pps. Moreover, delays due to wiring is reduced at its lowest thanks to the controller that is contained into de light, reducing the length of the cables and, thus, the inductivity.

These facts make iBlueDrive devices suitable for very fast applications. Synchronization has never been this easy!

► Smart concept

Devices specially designed with iBlueDrive technology have aluminum cases so heat dissipation is improved and fixing is reliable and secure.

Its compact size makes them suitable for little room applications.

► Photometric Stereo Ready

No complex wiring or multiple-output controller is needed anymore. With iBlueDrive 'Bulk Trigger' functionality you will be able to capture multiple pictures of the same part under different lighting conditions using a single trigger signal. Just share the train pulse to all the involved lights and configure the order in which you want them to be turned on.

Check our multisector and multispectral devices.

► The Right Choice

With iBlueDrive devices you will save start-up costs both programming and installing. Moreover, an iBlueDrive system is more economical than a conventional equivalent system plus its strobe controller

► iBlueDrive general specifications

Imaging technology is a cost-effective way to implement automatic quality assurance and control and is used in many different areas of application.

Cable	VCC Series
Terminal 1	24VDC ±8%
Terminal 2	0V
Terminal 3	Multifunctional control. Bidirectional data bus and multi-device, trigger signal and analog control function to adjust the power
Camera connection	Direct
Multi-device connection	Up to 20 devices
Escalable	Yes. RGB lights or sections using the same interface
Configuration	Factory configured. Valid for 90% of applications. The device detects the type of control signal
Control signal	Automatic. Detected by the device.
Linear adjustment of intensity	Yes. Between 0-100%
Short circuit protection	Yes
Reverse voltage protection	Yes
Over-temperature protection	Yes
Online programming	Yes
Offline programming	Yes
Interface	iBlueDrive Box
Control software	Free. iBlueDrive Control Manager

■ Connecting lamp to the computer (*ibluedrive box required*), you will be able to know:

Part number	Yes
Serial number	Yes
Current operating status	Yes
Power voltage	VCD that is receiving
Driver temperature	Yes
Led temperature	Yes
Current operating mode	Repose, Continuous, Powered or Strobe

■ Connecting lamp to the computer (*ibluedrive box required*), you will be able to configure:

Pulse width	Yes
Time off after trigger	Yes
General output power	Yes
Maximum configured power	For each operating mode

► iBlueDrive Built in or inline

There are two ways of including iBlueDrive technology in our products. iBlueDrive **Built in** when the strobe controller is integrated inside their chassis or iBlueDrive **inline**, when the driver for the new iBlueDrive technology is integrated as a box of 65x33mm. into the cable that links the lighting system with the connector

LED LIGHTING

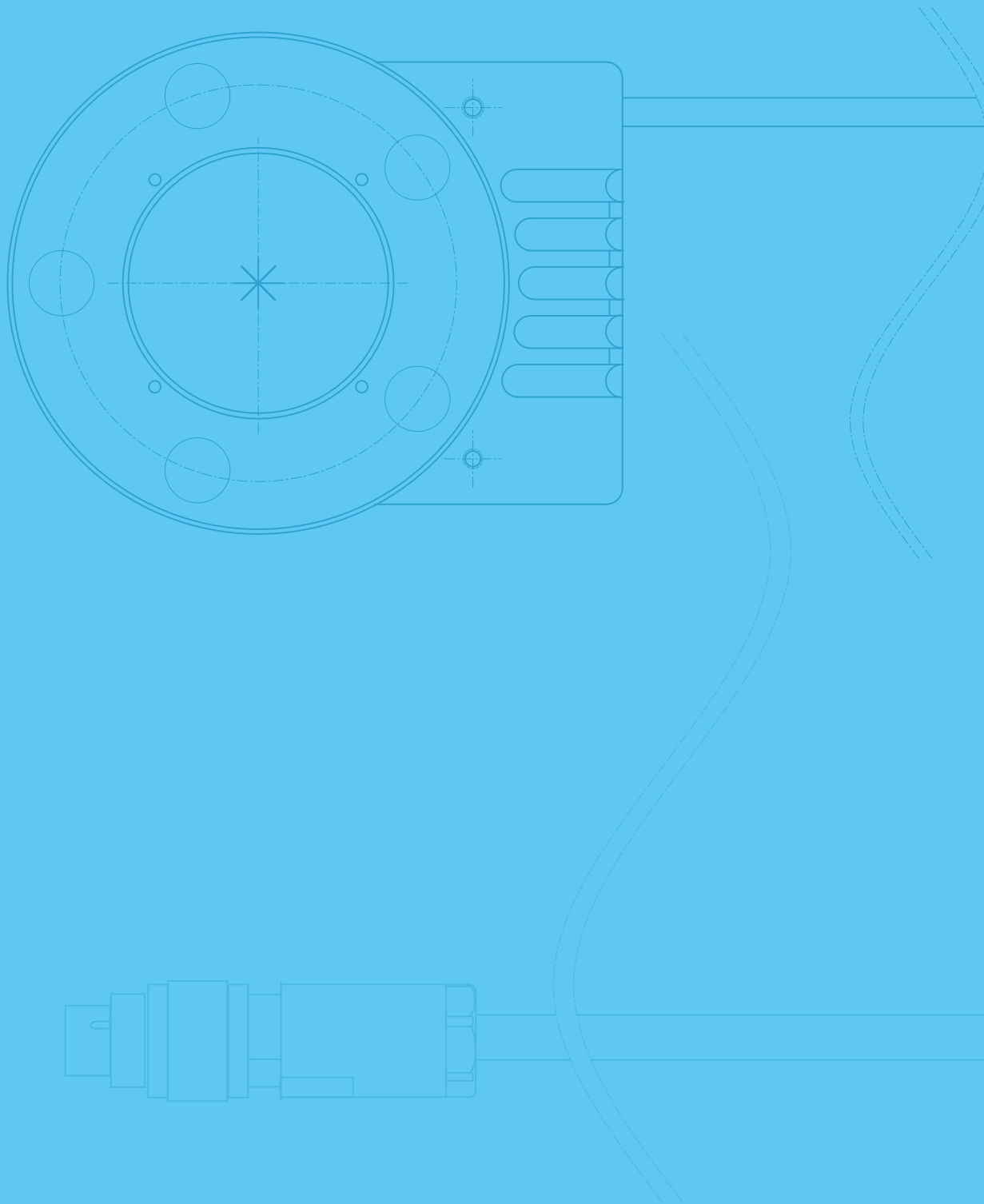

LED LIGHTING SYSTEMS



- ▶ **ALB** DIRECT HIGH-POWERED RINGLIGHTS
- ▶ **ALD** DIRECT RINGLIGHTS
- ▶ **ALS** DIFFUSE RINGLIGHTS
- ▶ **ALU** ULTRA-DIFFUSE RINGLIGHTS
- ▶ **ALW** LOW ANGLE ULTRA-DIFFUSE RINGLIGHTS
- ▶ **AUB** BORESCOPIC DIFFUSE RINGLIGHTS
- ▶ **BKC** CYLINDRICAL BACKLIGHTS
- ▶ **BKL** AREA BACKLIGHTS
- ▶ **BKM** LARGE AREA BACKLIGHTS
- ▶ **BKN** LINEAR BACKLIGHTS
- ▶ **DKL** DARKFIELDS LIGHTS
- ▶ **DOL** LINEAR DOME LIGHTS
- ▶ **DOM** DOME LIGHTS
- ▶ **DTL** TRANSMITTED DOME LIGHTS
- ▶ **PLA** HIGH-POWERED LINEAR LIGHTS PROJECTORS
- ▶ **PLC** COMPACT LINEAR LIGHTS PROJECTORS
- ▶ **PLD** DIRECT LINEAR LIGHTS PROJECTORS
- ▶ **PLU** DIFFUSE LINEAR LIGHTS PROJECTORS
- ▶ **PRA** COMPACT COAXIAL SPOT LIGHTING
- ▶ **PRC** COMPACT HIGH-POWERED LIGHTS PROJECTORS
- ▶ **PRD** SPOT PROJECTORS
- ▶ **PRF** ADJUSTABLE FOCUS LENS PROJECTORS
- ▶ **PRH** HIGH-POWERED LIGHTS PROJECTORS
- ▶ **PRK** HARSH ENVIRONMENT WASHDOWN HP PROJECTORS
- ▶ **PRL** LINE LIGHTS PROJECTORS
- ▶ **PRY** DIRECT LIGHTS PROJECTORS
- ▶ **SAC** DIFFUSE AXIAL COMPACT LIGHTS
- ▶ **SAL** 90° DIFFUSE AXIAL LIGHTS
- ▶ **SAR** DIFFUSE RING & 90° AXIAL LIGHTS
- ▶ **SAX** DIFFUSE AXIAL LIGHTS

ALB SERIES















Direct high-powered ringlights

Series of direct ringlights with high-powered leds. Designed with iBlueDrive technology for illuminating from the camera axis the non-reflective objects. These systems provide greater amount of light than ALD Series, which make them suitable for lighting objects from further distances. They highlight textures and contours and are available in several angles of emission and various supplementary filters for being much more versatile.

► Technical specifications¹

Lighting model	ALB0804A	ALB0810A	ALB1716A
			
Dimensions	94.5x77x16.5	94.5x77x16.5	168x168x38.5
Inner Ø	40	40	76
RWD (mm)	>50	>50	>50
Weight	120g	124g	940g
IP rating	IP40	IP40	IP65
Mounting holes	(x2)M4I5	(x2)M4I5	(x9)M4I6
Connection (Type C)	3P aerial male connector. L=150mm PIN 1 = +24V ±8% PIN 2 = 0V PIN 3 = Control	N/A	3P aerial male connector. L=150mm PIN 1 = +24V ±8% PIN 2 = 0V PIN 3 = Control
Power cable (Not-included)	VCC Series	N/A	VCC Series
Modifiers²			
Accessories³			
iBlueDrive tech.	Built-in	Built-in	Built-in
iBlueDrive connection	3P aerial male connector. L= 150mm. PIN 1 = +24V ±8% PIN 2 = 0V PIN 3 = Control ⁴	3P aerial male connector. L= 150mm. PIN 1 = +24V ±8% PIN 2 = 0V PIN 3 = Control ⁴	3P aerial male connector. L= 150mm. PIN 1 = +24V ±8% PIN 2 = 0V PIN 3 = Control ⁴
iBlueDrive power cable (Not-included)	VCC Series	VCC Series	VCC Series
iBlueDrive accessories³			

► Instantaneous consumption⁵ (max.)

Lighting model	ALB0804A	ALB0810A	ALB1716A	*WT
TYPE C 24VDC	 5.5W	N/A	20W	-365C
	 5.5W	N/A	22W	-400C
	 5.5W	N/A	20W	-470C
	 5.5W	N/A	20W	-525C
	 5.5W	N/A	20W	-630C
	 5W	N/A	10W	-850C
	 5.5W	N/A	17W	-W00C
TYPE P	No "Type P" standard LED lighting systems in this series			
TYPE S	No "Type S" standard LED lighting systems in this series			
TYPE i⁶ 	 12W [24W/7.7W]	15W [48W/10W]	48W [96W/24W]	-365i
	 12W [24W/7.7W]	15W [48W/10W]	48W [96W/24W]	-400i
	 12W [24W/7.7W]	15W [48W/10W]	48W [96W/24W]	-470i
	 12W [24W/7.7W]	15W [48W/10W]	26W [96W/13W]	-525i
	 12W [17W/7.7W]	15W [34W/10W]	26W [96W/13W]	-630i
	 12W [24W/7.7W]	12W [24W/6.5W]	26W [48W/13W]	-850i
	 12W [24W/7.7W]	15W [48W/10W]	26W [96W/13W]	-W00i

N/A= Not available

(1) Environmental specifications and iconography legend in additional annex Z1.4 and Z2 respectively.

(2) Angles of emission of ALB series ringlights. If not indicated, default angle will be /AM. Please, consult the code to select a different angle of emission before ordering (additional annex Z2.1).

(3) Accessories are not-included. More information in accessories section.

(4) iBlueDrive control input wiring specifications in additional annex Z1.2.

(5) Bear in mind that consumption table is only to be used as a guide. To refer to real values, please, consult product label when purchasing.

(6) Values of maximum instantaneous consumption of "Type I" lighting systems in **Powered mode [Strobe mode / Continuous mode]**



ALB SERIES

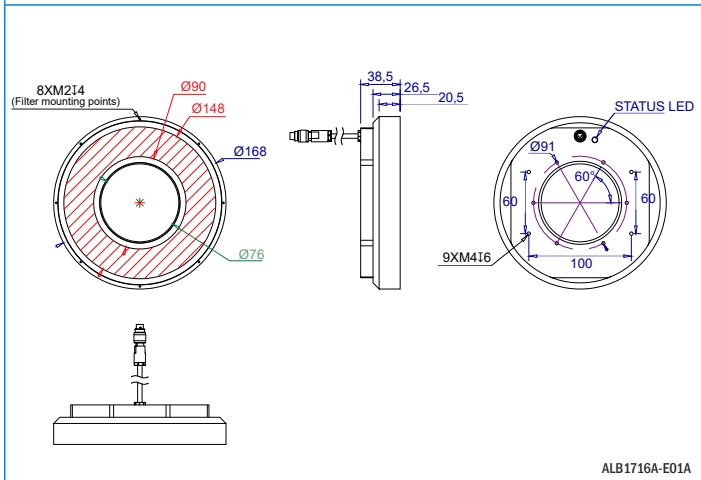
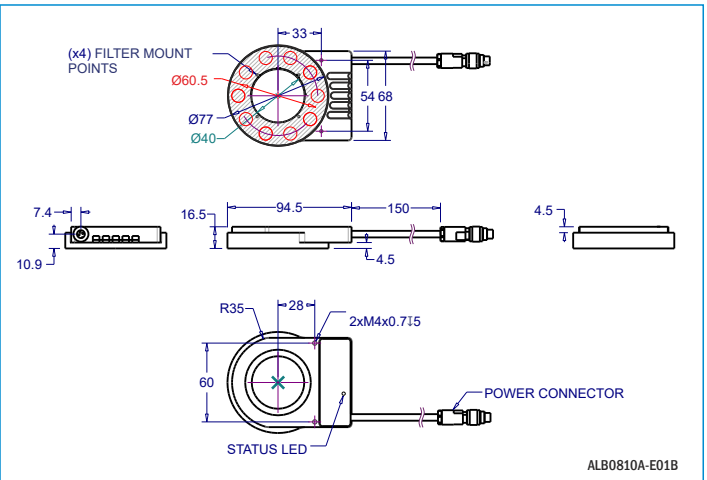
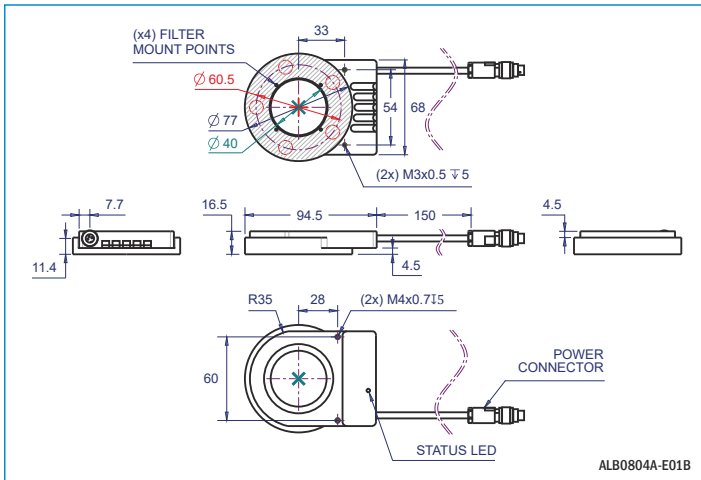

All units in millimeters, if not indicated.



Example of ALB captured image

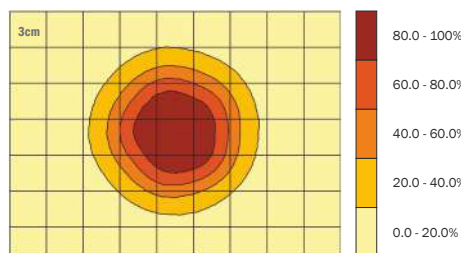

Brightness distribution of ALB0804A-630i/AM@100mm

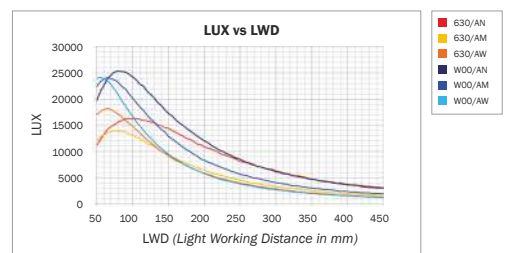

ALB0804A-630i light intensity.

ALD SERIES

Direct ringlights

Lighting systems to light from camera axis. They provide a huge quantity of light from a distant point so can be used to light objects from a further distance than those of use diffuse light.

Designed to stand out shadows, textures and edges.

Technical specifications¹

Lighting model	ALD0303A	ALD0606A	ALD0707A	ALD0907A	ALD1108A
Dimensions	48x48x27	Ø73x21	Ø90x21	Ø126x41	Ø145x41
Inner Ø	21	40	60	34	49
RWD (mm)	>40	>100	>120	>120	>160
Weight	75g	145g	175g	410g	525g
IP rating	IP40 ²	IP40	IP40	IP30	IP30
Mounting holes	(x2)M4I6 (x3)DIN913 M5@120°	(x2)M4I6 (x3)DIN913 M5@120°	(x2)M4I6 (x3)DIN913 M5@120°	(x2)M4I6 (x3)DIN913 M5@120°	(x2)M4I6 (x3)DIN913 M5@120°
Connection (Type C/P/S)	2P male chassis connector PIN 1 = +24V ±3% PIN 2 = 0V	2P male chassis connector PIN 1 = +24V ±3% PIN 2 = 0V	2P male chassis connector PIN 1 = +24V ±3% PIN 2 = 0V	2P male chassis connector PIN 1 = +24V ±3% PIN 2 = 0V	2P male chassis connector PIN 1 = +24V ±3% PIN 2 = 0V
Power cable (Not-included)	VCB Series	VCB Series	VCB Series	VCB Series	VCB Series
Modifiers³		N/A	N/A		
Accessories⁴					
iBlueDrive tech.	inline	inline	inline	Built-in	Built-in
iBlueDrive connection	3P aerial male inline connector. L= 715mm. PIN 1 = +24V ±8% PIN 2 = 0V PIN 3 = Control ⁵	3P aerial male inline connector. L= 715mm. PIN 1 = +24V ±8% PIN 2 = 0V PIN 3 = Control ⁵	3P aerial male inline connector. L= 715mm. PIN 1 = +24V ±8% PIN 2 = 0V PIN 3 = Control ⁵	3P male chassis connector PIN 1 = +24V ±8% PIN 2 = 0V PIN 3 = Control ⁵	3P male chassis connector PIN 1 = +24V ±8% PIN 2 = 0V PIN 3 = Control ⁵
iBlueDrive power cable (Not-included)	VCC Series	VCC Series	VCC Series	VCC Series	VCC Series
iBlueDrive accessories⁴					

Instantaneous consumption⁶ (max.)

*WT

Lighting model	ALD0303A	ALD0606A	ALD0707A	ALD0907A	ALD1108A		
TYPE C 24VDC		0.8W	2.5W	2.5W	7.6W	10W	-470C
		0.8W	2.5W	2.5W	7.6W	10W	-525C
		1.3W	3.5W	3.5W	7.6W	9.5W	-630C
		1.3W	2W	2W	6.4W	8.2W	-850C
TYPE P D _{max} = 1/2 Ton max = 60s		1.1W	2.6W	2.6W	9.5W	13W	-365P
		1.1W	3.1W	3.1W	9.5W	13W	-400P
		1.1W	3.1W	3.1W	8W	11W	-W00P
TYPE S D _{max} = 1/20 Ton max = 2ms		175mA/4.2W	530mA/13W	530mA/13W	1585mA/38W	2110mA/51W	-365S
		175mA/4.2W	530mA/13W	530mA/13W	1585mA/38W	2110mA/51W	-400S
		175mA/4.2W	530mA/13W	530mA/13W	1585mA/38W	2110mA/51W	-470S
		110mA/2.6W	330mA/7.9W	330mA/7.9W	990mA/24W	1320mA/32W	-525S
		175mA/4.2W	530mA/13W	530mA/13W	1585mA/38W	2110mA/51W	-630S
		420mA/10W	625mA/16W	625mA/16W	2300mA/55W	2925mA/70W	-850S
		175mA/4.2W	530mA/15W	530mA/13W	1585mA/38W	2110mA/51W	-W00S
		N/A	200mA/4.8W channel	200mA/4.8W channel	1200mA/29W channel	1500mA/36W channel	-RGBS
TYPE i⁷ 		1.1W[5.3W/0.9W]	2.2W[15W/1.6W]	2.2W[15W/1.6W]	5.7W[44W/3.9W]	7.2W[48W/5.2W]	-365i
		1.4W[5.3W/1W]	3.4W[15W/1.9W]	3.4W[15W/1.9W]	9.1W[44W/4.8W]	12W[48W/6.2W]	-400i
		1.3W[5.3W/1.1W]	3.1W[15W/2.2W]	3.1W[15W/2.2W]	8.3W[44W/5.7W]	11W[48W/7.4W]	-470i
		1.2W[2.9W/0.9W]	2.6W[7.7W/1.6W]	2.6W[7.7W/1.6W]	7W[22W/3.9W]	9.1W[29W/5.1W]	-525i
		1.9W[5.3W/1.4W]	4.8W[15W/3.4W]	4.8W[15W/3.4W]	13W[44W/7.4W]	18W[48W/9.7W]	-630i
		3.1W[10W/1.9W]	4.4W[15W/2.6W]	4.4W[15W/2.6W]	14W[48W/7.1W]	17W[48W/8.9W]	-850i
		1.4W[5.3W/1W]	3.4W[15W/1.9W]	3.4W[15W/1.9W]	9.1W[44W/4.8W]	12W[48W/6.2W]	-W00i

N/A= Not available

(1) Environmental specifications and iconography legend in additional annex Z1.4 and Z2 respectively.
 (2) IP43 if the system is positioned so that the light falls vertically.
 (3) Prior to manufacturing optional modifications in standard lighting systems. Please, consult the code before ordering (additional annex Z2.1).

(4) Accessories are not-included. More information in accessories section.
 (5) iBlueDrive control input wiring specifications in additional annex Z1.2.
 (6) Bear in mind that consumption table is only to be used as a guide. To refer to real values, please, consult product label when purchasing.
 (7) Values of maximum instantaneous consumption of 'Type i' lighting systems in Powered mode [Strobe mode / Continuous mode]



ALD SERIES

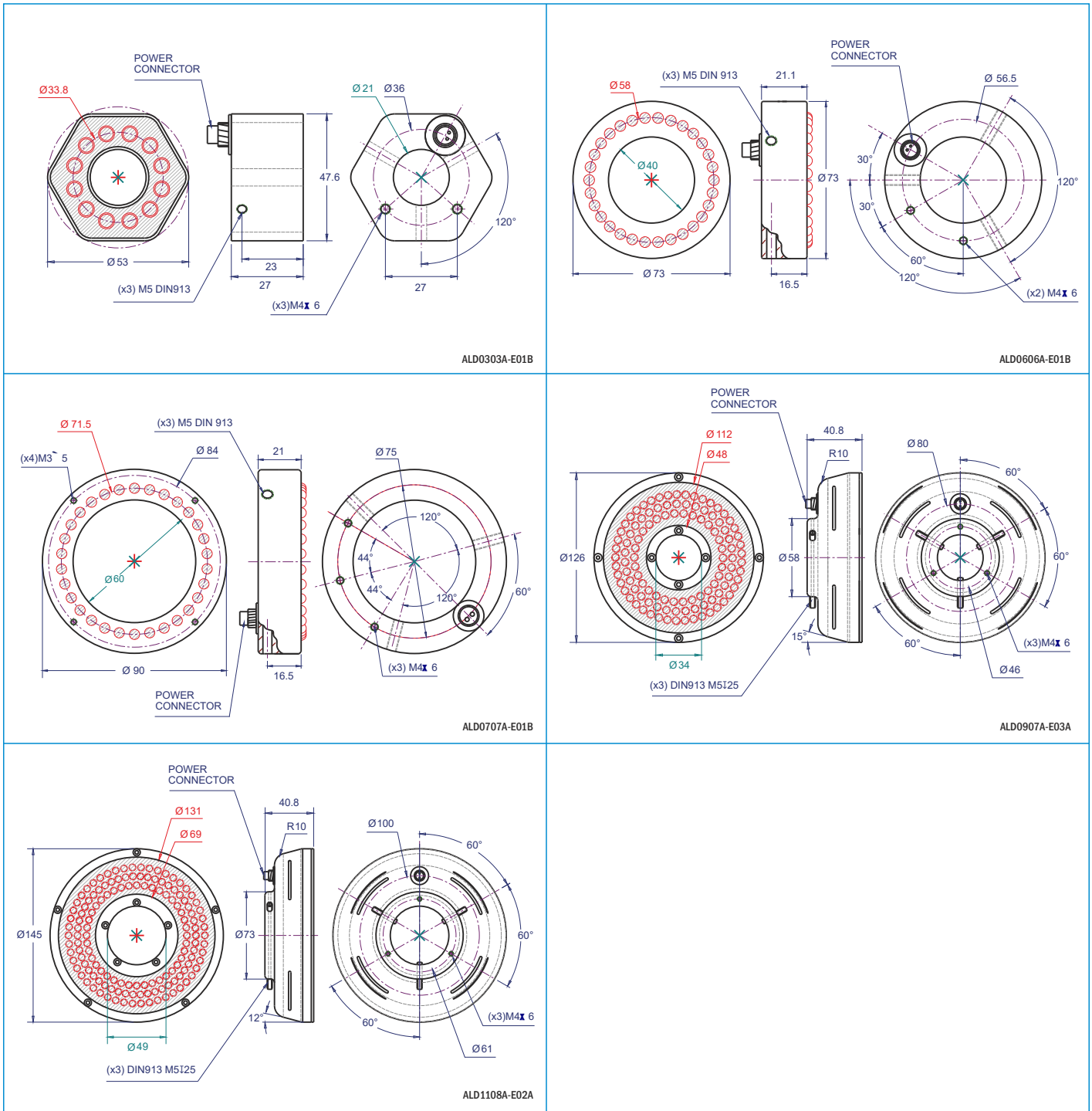

All units in millimeters, if not indicated.

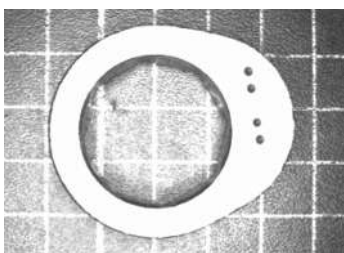

Example of ALD captured image

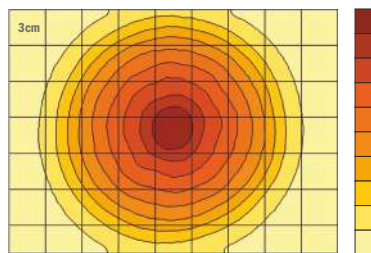

Brightness distribution of ALD1108A-630C@165mm

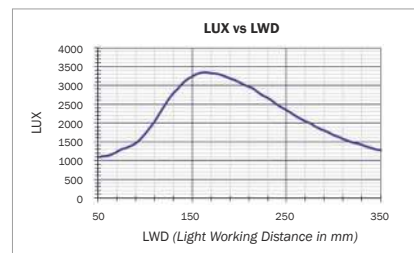

ALD1108A-630C light intensity.

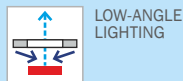

ALS SERIES

Diffuse ringlights

This system provides an ideal frontal diffuse light to obtain great contrast and uniformity. It is placed on camera axis. This application allows the illumination of reflecting objects making textures uniform, eliminating reflections and reducing shadows.

Technical specifications¹

Lighting model	ALSO402A	ALS1105A	ALS1307A	ALS1612A	ALS2315A
Dimensions	48x48x27	Ø126x41	Ø145x41	176x176x13	245x245x13
Inner Ø	21	34	49	120	145
RWD (mm)	>40	>50	>80	70 < x < 320	80 < x < 400
Weight	75g	410g	525g	410g	880g
IP rating	IP40 ²	IP30	IP30	IP40 ²	IP40 ²
Mounting holes	(x2)M4I6 (x3)DIN913 M5@120°	(x2)M4I6 (x3)DIN913 M5@120°	(x3)M4I6 (x3)DIN913 M5@120°	(x3)M4I6 (x3)DIN913 M5@120°	(x7)M4.25xTHRU
Connection (Type C/P/S)	2P male chassis connector PIN 1 = +24V ±3% PIN 2 = 0V	2P male chassis connector PIN 1 = +24V ±3% PIN 2 = 0V	2P male chassis connector PIN 1 = +24V ±3% PIN 2 = 0V	2P male chassis connector PIN 1 = +24V ±3% PIN 2 = 0V	2P male chassis connector PIN 1 = +24V ±3% PIN 2 = 0V
Power cable (Not-included)	VCB Series	VCB Series	VCB Series	VCB Series	VCB Series
Modifiers ³					
Accessories ⁴					
iBlueDrive tech.	inline	Built-in	Built-in	inline	inline
iBlueDrive connection	3P aerial male inline connector. L= 715mm. PIN 1 = +24V ±8% PIN 2 = 0V PIN 3 = Control ⁵	3P male chassis connector PIN 1 = +24V ±8% PIN 2 = 0V PIN 3 = Control ⁵	3P male chassis connector PIN 1 = +24V ±8% PIN 2 = 0V PIN 3 = Control ⁵	3P aerial male inline connector. L= 715mm. PIN 1 = +24V ±8% PIN 2 = 0V PIN 3 = Control ⁵	3P aerial male inline connector. L= 715mm. PIN 1 = +24V ±8% PIN 2 = 0V PIN 3 = Control ⁵
iBlueDrive power cable (Not-included)	VCC Series	VCC Series	VCC Series	VCC Series	VCC Series
iBlueDrive accessories ⁴					

Instantaneous consumption⁶ (max.)

*WT

Lighting model	ALSO402A	ALS1105A	ALS1307A	ALS1612A	ALS2315A		
TYPE C 24VDC		0.8W	7.6W	10W	11W	17W	-470C
		0.8W	7.6W	10W	11W	17W	-525C
		1.3W	7.6W	9.5W	10W	19W	-630C
		1.3W	6.4W	8.2W	10W	21W	-850C
		N/A	N/A	N/A	11W	17W	-W00C
TYPE P D _{max} = 1/2 Ton max = 60s		1.1W	9.5W	13W	N/A	N/A	-400P
		1.1W	8W	11W	N/A	N/A	-W00P
TYPE S D _{max} = 1/20 Ton max = 2ms		175mA / 4.2W	1585mA / 38W	2110mA / 51W	N/A	N/A	-400S
		175mA / 4.2W	1585mA / 38W	2110mA / 51W	2110mA / 51W	3170mA / 76W	-470S
		110mA / 2.6W	990mA / 24W	1320mA / 32W	2110mA / 51W	3170mA / 76W	-525S
		175mA / 4.2W	970mA / 23W	2110mA / 51W	2110mA / 51W	3170mA / 76W	-630S
		420mA / 10W	2300mA / 55W	2925mA / 70W	3760mA / 90W	8800mA / 211W	-850S
		175mA / 4.2W	1585mA / 38W	2110mA / 51W	2110mA / 51W	3170mA / 76W	-W00S
TYPE i ⁷ 		1.4W[5.3W/1W]	9.1W[44W/4.8W]	12W[48W/6.2W]	N/A	N/A	-400i
		1.3W[5.3W/1.1W]	8.3W[44W/5.7W]	11W[48W/7.4W]	11W[48W/8W]	16W[48W/12W]	-470i
		1.2W[2.9W/0.9W]	7W[22W/3.9W]	9.1W[29W/5.1W]	18W[48W/12W]	16W[48W/12W]	-525i
		1.9W[5.3W/1.4W]	13W[44W/7.4W]	18W[48W/9.1W]	18W[48W/12W]	24W[48W/16W]	-630i
		3.1W[10W/1.9W]	14W[48W/7.1W]	17W[48W/8.9W]	26W[48W/13W]	24W[48W/16W]	-850i
		1.4W[5.3W/1W]	9.1W[44W/4.8W]	12W[48W/6.2W]	18W[48W/12W]	26W[48W/18W]	-W00i
		N/A	1200mA / 29W channel	1500mA / 36W channel	2400mA / 58W channel	3000mA / 72W channel	-RGBS

N/A= Not available

(1) Environmental specifications and iconography legend in additional annex Z1.4 and Z2 respectively.
 (2) IP43 if the system is positioned so that the light falls vertically.
 (3) Prior to manufacturing optional modifications in standard lighting systems. Please, consult the code before ordering (additional annex Z2.1).

(4) Accessories are not-included. More information in accessories section.
 (5) iBlueDrive control input wiring specifications in additional annex Z1.2.
 (6) Bear in mind that consumption table is only to be used as a guide. To refer to real values, please, consult product label when purchasing.
 (7) Values of maximum instantaneous consumption of 'Type i' lighting systems in Powered mode [Strobe mode / Continuous mode]



ALS SERIES

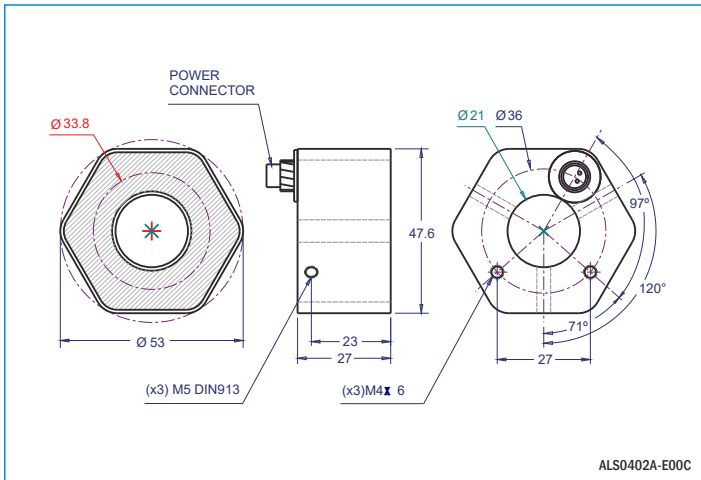

ALS0402A-E00C

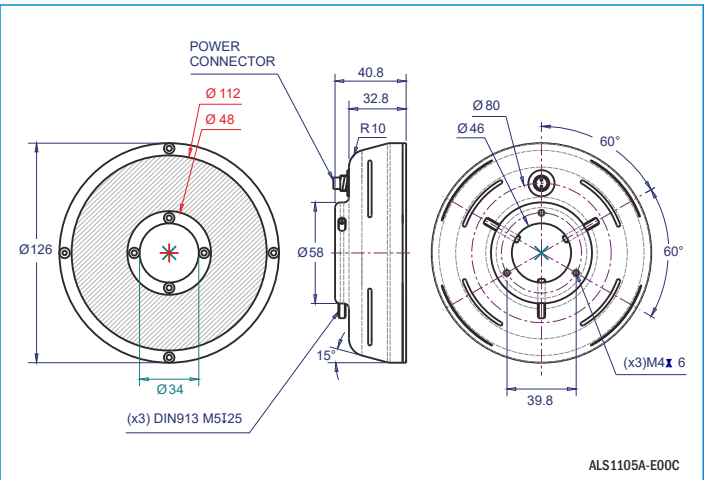

ALS1105A-E00C

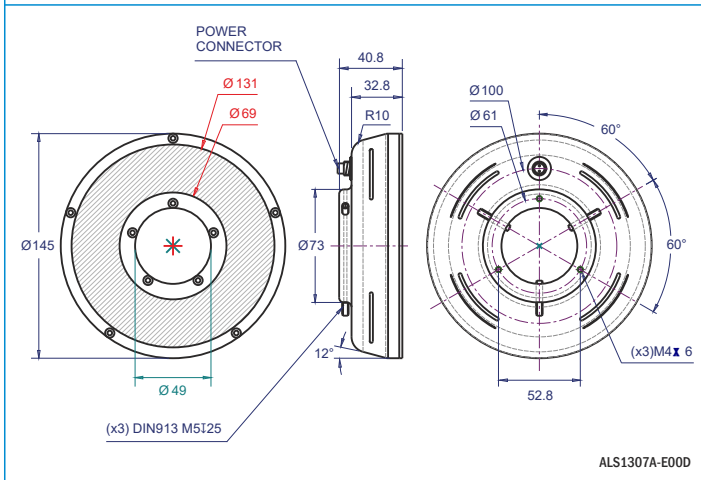

ALS1307A-E00D

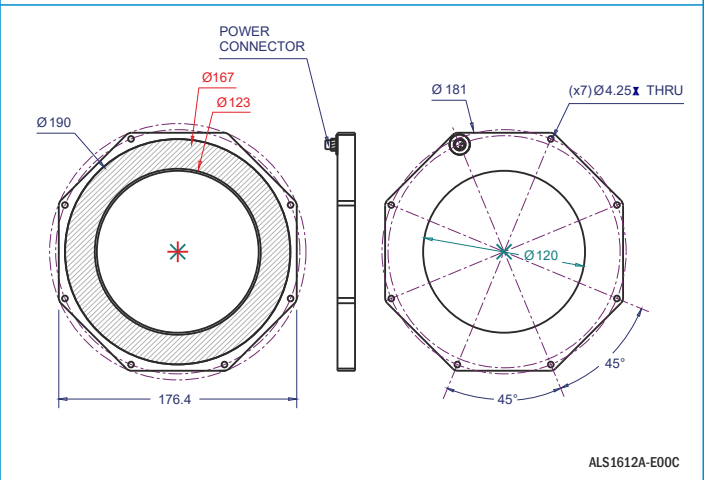

ALS1612A-E00C

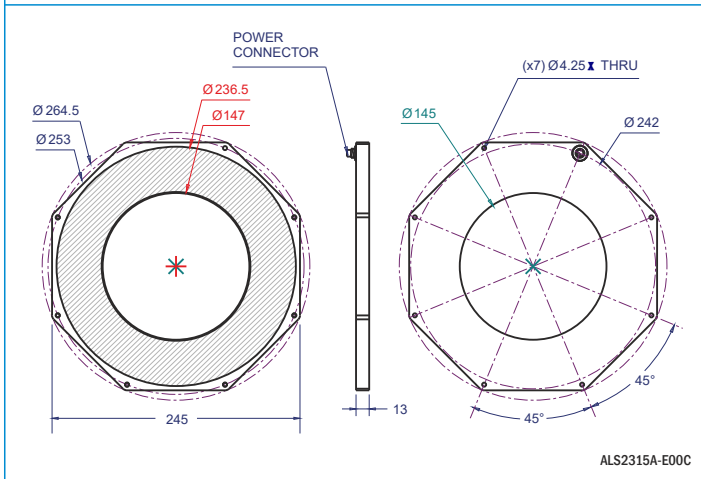

ALS2315A-E00C

All units in millimeters, if not indicated.

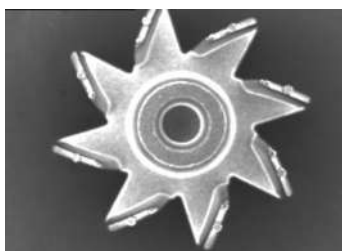

Example of ALS captured image

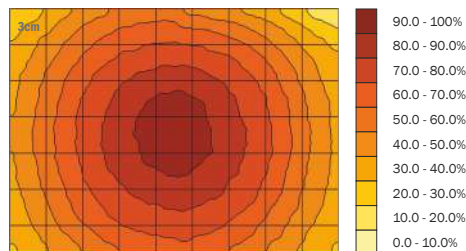

Brightness distribution of ALS1105A-630C@350mm

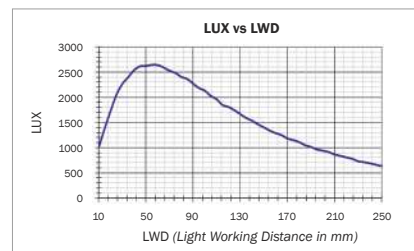

ALS1105A-630C light intensity.

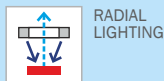

RADIAL LIGHTING

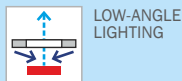

LOW-ANGLE LIGHTING



BACK-LIGHT

ALU SERIES

Ultra diffuse ringlights

Ringlights are used to illuminate objects from camera axis providing a ULTRA-DIFFUSE and uniform frontal light, ideal to obtain contrast and uniformity in order to inspect brightly or specular shining objects.

Eliminates brightness and shadows.

► Technical specifications¹

Lighting model	ALU0502A	ALU0704A	ALU1006A
Dimensions	55x55x20	75x75x22	100x100x28
Inner Ø	20	37	61
RWD (mm)	<115	<120	<190
Weight	85g	130g	260g
IP rating	IP40 ²	IP40 ²	IP40 ²
Mounting holes	(x3)M4T6	(x4)M4T6	(x4)M4T6 (x3)DIN913 M5@120°
Connection (Type C/S)	2P male chassis connector PIN 1 = +24V ±3% PIN 2 = 0V	2P male chassis connector PIN 1 = +24V ±3% PIN 2 = 0V	2P male chassis connector PIN 1 = +24V ±3% PIN 2 = 0V
Power cable (Not-included)	VCB Series	VCB Series	VCB Series
Modifiers ³			
Accessories ⁴			
iBlueDrive tech.	inline	inline	inline
iBlueDrive connection	3P aerial male inline connector. L= 715mm. PIN 1 = +24V ±8% PIN 2 = 0V PIN 3 = Control ⁵	3P aerial male inline connector. L= 715mm. PIN 1 = +24V ±8% PIN 2 = 0V PIN 3 = Control ⁵	3P aerial male inline connector. L= 715mm. PIN 1 = +24V ±8% PIN 2 = 0V PIN 3 = Control ⁵
iBlueDrive power cable (Not-included)	VCC Series	VCC Series	VCC Series
iBlueDrive accessories ⁴			

► Instantaneous consumption⁶ (max.)

Lighting model	ALU0502A	ALU0704A	ALU1006A	*WT	
TYPE C 24VDC		2.2W	3.4W	5.5W	-470C
		2.2W	3.4W	5.5W	-525C
		2.5W	3.8W	6.4W	-630C
		2.5W	3.8W	6.4W	-850C
		2.2W	3.4W	5.5W	-W00C
TYPE P	No "Type P" standard LED lighting systems in this series				
TYPE S D _{max} = 1/20 Ton max= 2ms		350mA/8.4W	530mA/13W	880mA/21W	-470S
		350mA/8.4W	530mA/13W	880mA/21W	-525S
		350mA/8.4W	530mA/13W	880mA/21W	-630S
		835mA/20W	1255mA/30W	2090mA/50W	-850S
		350mA/8.4W	530mA/13W	880mA/21W	-W00S
TYPE i ⁷ 		N/A	600mA/14W channel	1000mA/24W channel	-RGBS
		2.2W[10W/1.7W]	3.1W[15W/2.4W]	4.8W[24W/3.6W]	-470i
		3.4W[10W/2.4W]	4.8W[15W/3.4W]	7.7W[24W/5.3W]	-525i
		3.4W[10W/2.4W]	4.8W[15W/3.4W]	7.7W[24W/5.3W]	-630i
		6.2W[20W/3.4W]	9.1W[29W/4.8W]	15W[48W/7.7W]	-850i
	3.4W[10W/2.4W]	4.8W[15W/3.4W]	7.7W[24W/5.3W]	-W00i	

N/A= Not available

(1) Environmental specifications and iconography legend in additional annex Z1.4 and Z2 respectively.

(2) IP43 if the system is positioned so that the light falls vertically.

(3) Prior to manufacturing optional modifications in standard lighting systems. Please, consult the code before ordering (additional annex Z2.1).

(4) Accessories are not-included. More information in accessories section.

(5) iBlueDrive control input wiring specifications in additional annex Z1.2.

(6) Bear in mind that consumption table is only to be used as a guide. To refer to real values, please, consult product label when purchasing.

(7) Values of maximum instantaneous consumption of "Type i" lighting systems in Powered mode [Strobe mode / Continuous mode]



ALU SERIES

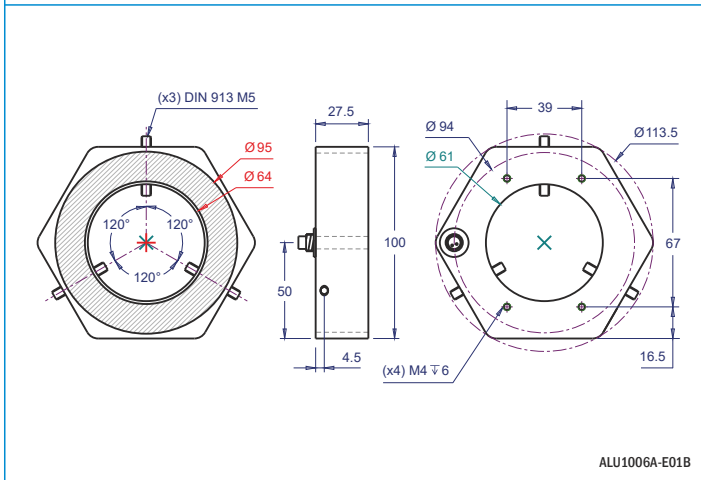
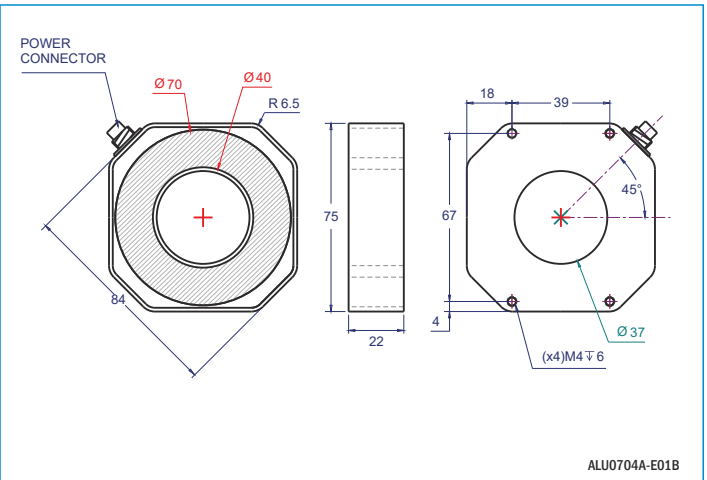
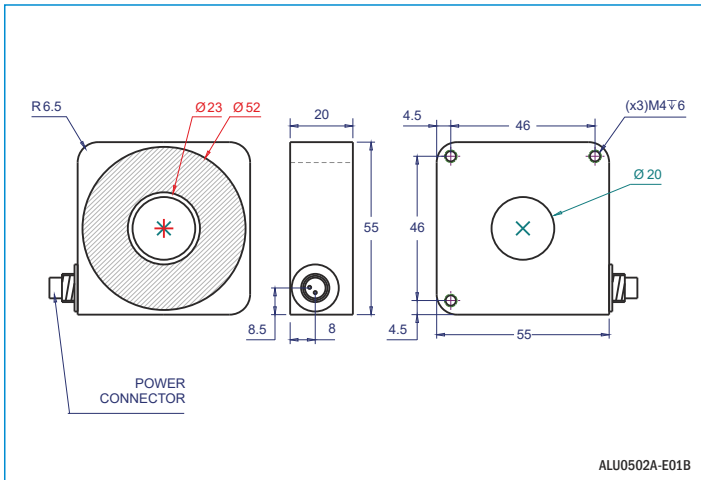

All units in millimeters, if not indicated.

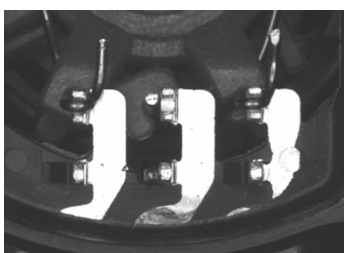

Example of ALU captured image

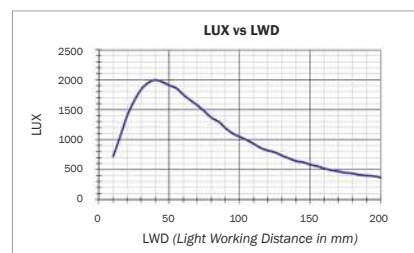
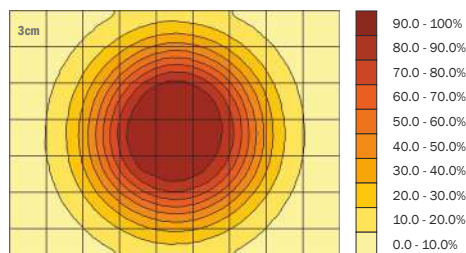

ALU1006A-630C light intensity.



RADIAL LIGHTING

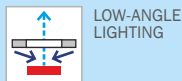





LOW-ANGLE LIGHTING

ALW SERIES

















Low angle ultra diffuse ringlights

Low angle ringlight. Light is emitted towards the center of the ring system with a medium inclination, which makes the lighting be uniform and avoids brightness while allowing the highlighting of edges, cracks and deep cavities. Moreover, this light avoids reflection, specially in bright elements. In longer Lighting Working Distances (LWD) it works as a ringlight and in shorter LWD works as a darkfield.

► Technical specifications¹

Lighting model	ALW2922A
	
Dimensions	307x292x15
Inner Ø	223
RWD (mm)	<350
Weight	550g
IP rating	IP40
Mounting holes	(x8)M5I6
Connection (Type C/S)	2P aerial male connector. L= 150mm. PIN 1 = +24V ±3% PIN 2 = 0V
Power cable (Not-included)	VCB Series
Modifiers ²	
Accessories ³	
iBlueDrive tech.	inline
iBlueDrive connection	3P aerial male inline connector. L= 715mm PIN 1 = +24V ±8% PIN 2 = 0V PIN 3 = Control ⁴
iBlueDrive power cable (Not-included)	VCC Series
iBlueDrive accessories ³	

► Instantaneous consumption⁵ (max.)

Lighting model	ALW2922A	*WT
TYPE C 24VDC	 13W	-470C
	 13W	-525C
	 17W	-630C
	 18W	-850C
	 13W	-W00C
TYPE P	No "Type P" standard LED lighting systems in this series	
TYPE S Dmax= 1/2° Ton max= 2ms	 2465mA/59W	-470S
	 2465mA/59W	-525S
	 2465mA/59W	-630S
	 5850mA/140W	-850S
	 2465mA/59W	-W00S
	 4000mA/96W channel	-RGBS
TYPE i ⁶ 	 13W[48W/9.2W]	-470i
	 21W[48W/14W]	-525i
	 21W[48W/14W]	-630i
	 23W[96W/12W]	-850i
	 21W[48W/14W]	-W00i

(1) Environmental specifications and iconography legend in additional annex Z1.4 and Z2 respectively.

(2) Prior to manufacturing optional modifications in standard lighting systems. Please, consult the code before ordering (additional annex Z2.1).

(3) Accessories are not-included. More information in accessories section.

(4) iBlueDrive control input wiring specifications in additional annex Z1.2.

(5) Bear in mind that consumption table is only to be used as a guide. To refer to real values, please, consult product label when purchasing.

(6) Values of maximum instantaneous consumption of "Type i" lighting systems in **Powered mode (Strobe mode / Continuous mode)**



ALW SERIES

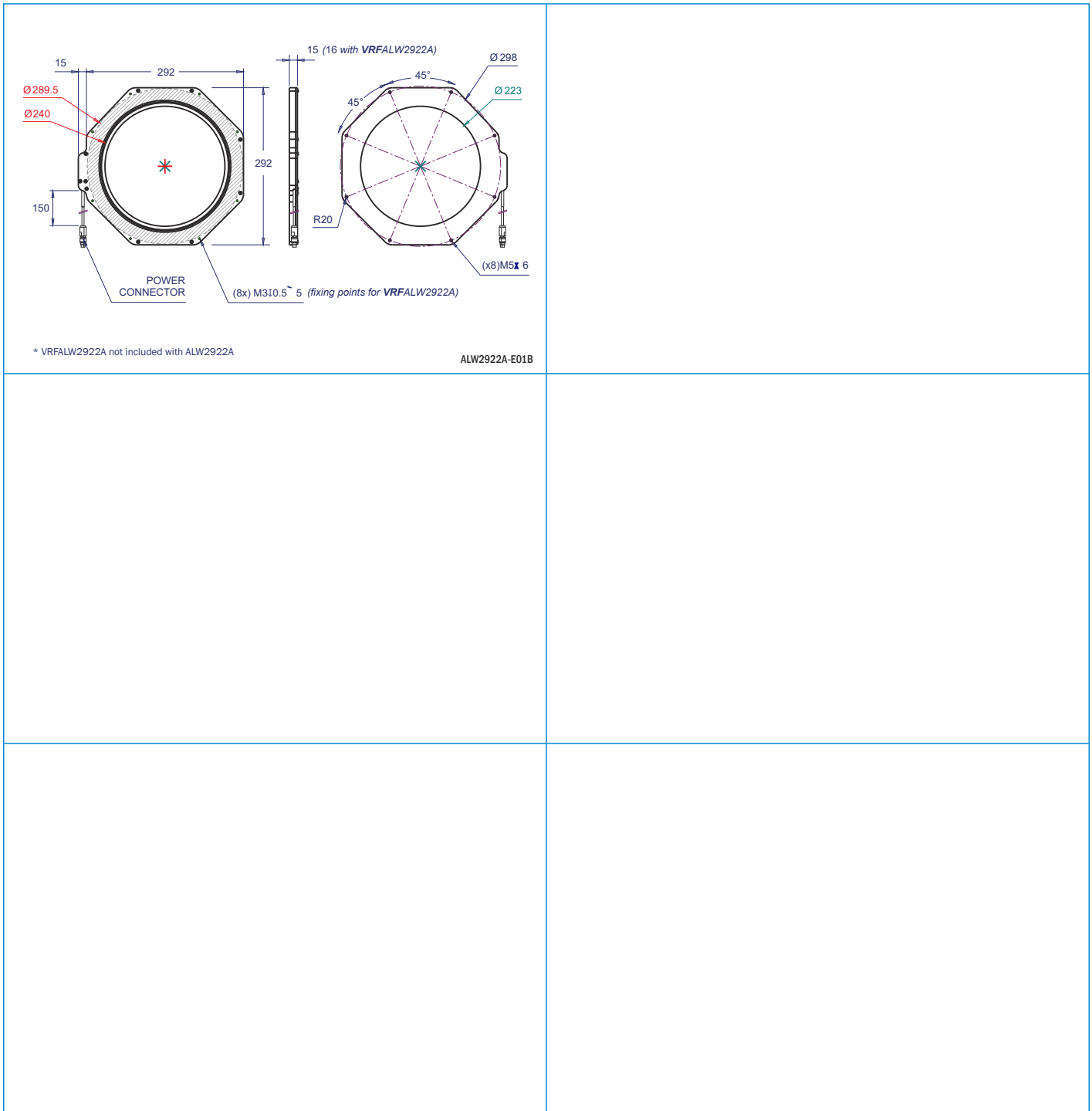

All units in millimeters, if not indicated.

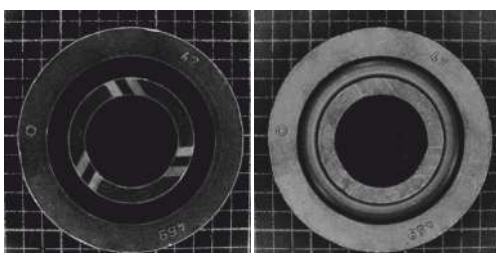

Example of ALW captured image

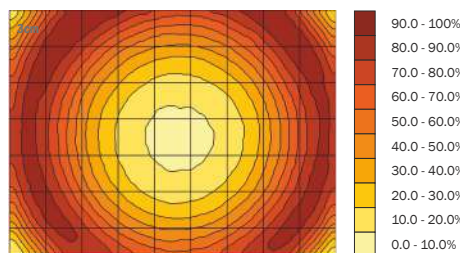

Brightness distribution of ALW2922A-630C@50mm

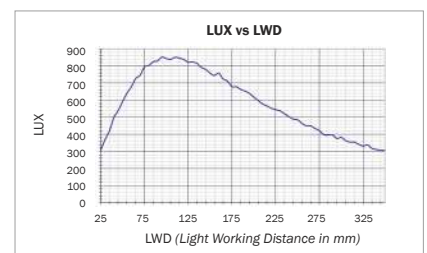

ALW2922A-630C light intensity.

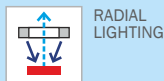





AUB SERIES

Borescopic diffuse ringlights

Ringlight specially thought for borescopic optics. It increases the working distance and it's great power decreases the exposure time reducing the inspection cycle time. Compatible with the Boroscopic optic PCBP012 from Opto Engineering.

► Technical specifications¹

Lighting model	AUB0402A
	
Dimensions	Ø44x45
Inner Ø	22mm
RWD (mm)	<50
Weight	100g
IP rating	IP40
Mounting holes	(x3)M4I6
Connection (Type C)	3P aerial male connector. L= 150mm. PIN 1 = +24V ±8% PIN 2 = 0V PIN 3 = Control
Power cable (Not-included)	VCC Series
Modifiers ²	N/A
Accessories ³	
iBlueDrive tech.	inline
iBlueDrive connection	3P aerial male inline connector. L= 715mm PIN 1 = +24V ±8% PIN 2 = 0V PIN 3 = Control ⁴
iBlueDrive power cable (Not-included)	VCC Series
iBlueDrive accessories ³	

► Instantaneous consumption⁵ (max.)

Lighting model	AUB0402A	*WT
TYPE C 24VDC	 4W	-470C
	 4W	-525C
	 4W	-630C
	 4W	-850C
	 4W	-W00C
TYPE P	No "Type P" standard LED lighting systems in this series	
TYPE S	No "Type S" standard LED lighting systems in this series	
TYPE i ⁶ 	 7.7W[48W/4.1W]	-470i
	 7.7W[48W/4.1W]	-525i
	 7.7W[34W/4.1W]	-630i
	 7.7W[48W/4.1W]	-850i
	 7.7W[48W/4.1W]	-W00i

(1) Environmental specifications and iconography legend in additional annex Z1.4 and Z2 respectively.
 (2) Prior to manufacturing optional modifications in standard lighting systems. Please, consult the code before ordering (additional annex Z2.1).
 (3) Accessories are not-included. More information in accessories section.

(4) iBlueDrive control input wiring specifications in additional annex Z1.2.
 (5) Bear in mind that consumption table is only to be used as a guide. To refer to real values, please, consult product label when purchasing.
 (6) Values of maximum instantaneous consumption of "Type i" lighting systems in Powered mode [Strobe mode / Continuous mode]



AUB SERIES

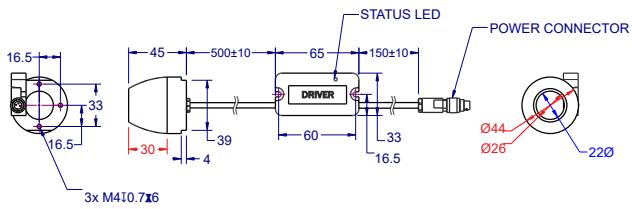

AUB0402A-E01

All units in millimeters, if not indicated.

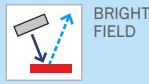





BKC SERIES

















Cylindrical backlights

Cylindrical backlights that emit homogeneous diffuse lighting in the 360° of their circular surface, allowing their use from several angles at the same time, for complete backlight inspection of hollow objects such as pipes, deposits and boxes or for inspection from different angles in carousels or turntables.

► Technical specifications¹

Lighting model	BKC0806A
	
Dimensions	Ø60x100
Active surface	Ø60x60
Weight	260g
IP rating	IP40
Mounting holes	(x2)M4I6
Connection (Type C/S)	2P male chassis connector PIN 1 = +24V ±3% PIN 2 = 0V
Power cable (Not-included)	VCB Series
Modifiers ²	N/A
Accessories ³	
iBlueDrive tech.	inline
iBlueDrive connection	3P aerial male inline connector. L= 715mm. PIN 1 = +24V ±8% PIN 2 = 0V PIN 3 = Control ⁴
iBlueDrive power cable (Not-included)	VCC Series
iBlueDrive accessories ³	

► Instantaneous consumption⁵ (max.)

Lighting model	BKC0806A		*WT
TYPE C 24VDC		7.4W	-470C
		11W	-525C
		5.3W	-630C
		6.4W	-850C
		7.4W	-W00C
TYPE P	No "Type P" standard LED lighting systems in this series		
TYPE S D _{max} = 1/2 ^o Ton max= 2ms		1760mA/42W	-470S
		1760mA/42W	-525S
		1760mA/42W	-630S
		2020mA/48W	-850S
		1760mA/42W	-W00S
TYPE i ⁶ 		9.1W[48W/6.7W]	-470i
		15W[48W/10W]	-525i
		15W[48W/10W]	-630i
		15W[48W/7.7W]	-850i
		15W[48W/10W]	-W00i

(1) Environmental specifications and iconography legend in additional annex Z1.4 and Z2 respectively.

(2) Prior to manufacturing optional modifications in standard lighting systems. Please, consult the code before ordering (additional annex Z2.1).

(3) Accessories are not-included. More information in accessories section.

(4) iBlueDrive control input wiring specifications in additional annex Z1.2.

(5) Bear in mind that consumption table is only to be used as a guide. To refer to real values, please, consult product label when purchasing.

(6) Values of maximum instantaneous consumption of "Type i" lighting systems in Powered mode [Strobe mode / Continuous mode]



BKC SERIES

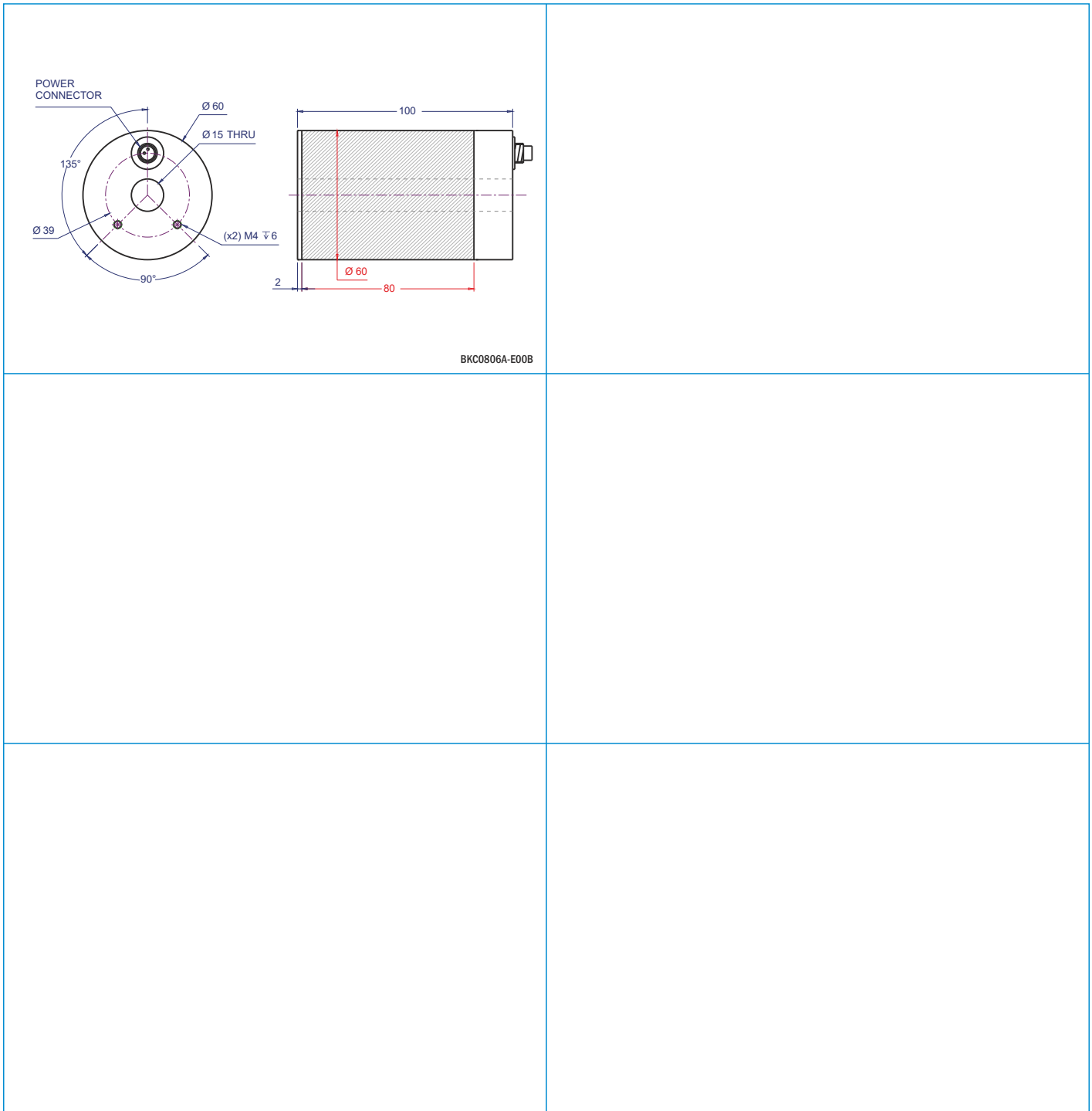

All units in millimeters, if not indicated.

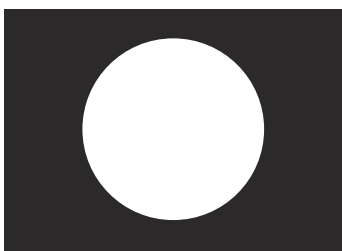

Example of BKC captured image

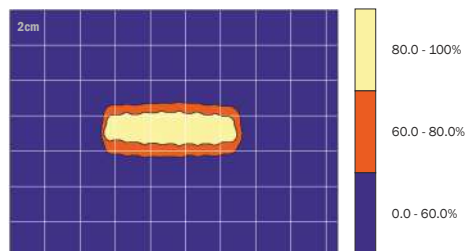

Brightness distribution of BKC0806A-630C

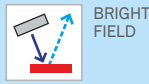
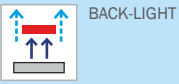

BKL SERIES

Area backlights (1/3) - BKL0303A to BKL1007B

Posterior diffuse lighting system usually design to measure precisely or emphasize light-dark differences by contrast that allows to have good images of object's shape.

Are used to inspect profiles and edges also used for bright fields creation.

Technical specifications¹

Lighting model	BKL0303A	BKL0504B	BKL0505A	BKL0705B	BKL0707B	BKL1007B
Dimensions	40x34x22	52x55x22	62x55x22	75x75x22	86x77x22	89x107x22
Active surface	30x30	40x50	50x50	50x70	70x70	70x100
Weight	45g	85g	91g	185g	196g	255g
IP rating	IP40	IP40	IP40	IP40	IP40	IP40
Mounting holes	(x2)M4I6	(x4)M4I6	(x4)M4I6	(x6)M4I6	(x6)M4I6	(x6)M4I6
Connection (Type C/S)	2P male chassis connector PIN 1 = +24V ±3% PIN 2 = 0V	2P male chassis connector PIN 1 = +24V ±3% PIN 2 = 0V	2P male chassis connector PIN 1 = +24V ±3% PIN 2 = 0V	2P male chassis connector PIN 1 = +24V ±3% PIN 2 = 0V	2P male chassis connector PIN 1 = +24V ±3% PIN 2 = 0V	2P male chassis connector PIN 1 = +24V ±3% PIN 2 = 0V
Power cable (Not-included)	VCB Series	VCB Series	VCB Series	VCB Series	VCB Series	VCB Series
Modifiers²	N/A	N/A	N/A	N/A	N/A	N/A
Accessories³		 	 	 	 	
iBlueDrive tech.	inline	inline	inline	inline	inline	inline
iBlueDrive connection	3P aerial male inline connector. L= 715mm. PIN 1 = +24V ±8% PIN 2 = 0V PIN 3 = Control ⁴	3P aerial male inline connector. L= 715mm. PIN 1 = +24V ±8% PIN 2 = 0V PIN 3 = Control ⁴	3P aerial male inline connector. L= 715mm. PIN 1 = +24V ±8% PIN 2 = 0V PIN 3 = Control ⁴	3P aerial male inline connector. L= 715mm. PIN 1 = +24V ±8% PIN 2 = 0V PIN 3 = Control ⁴	3P aerial male inline connector. L= 715mm. PIN 1 = +24V ±8% PIN 2 = 0V PIN 3 = Control ⁴	3P aerial male inline connector. L= 715mm. PIN 1 = +24V ±8% PIN 2 = 0V PIN 3 = Control ⁴
iBlueDrive power cable (Not-included)	VCC Series	VCC Series	VCC Series	VCC Series	VCC Series	VCC Series
iBlueDrive accessories³	 	 	 	 	 	

Instantaneous consumption⁵ (max.)

Lighting model	BKL0303A	BKL0504B	BKL0505A	BKL0705B	BKL0707B	BKL1007B	*WT	
TYPE C 24VDC		1.2W	1.4W	2.3W	3.1W	4.2W	5.3W	-470C
		1W	1.8W	1.9W	2.4W	3.5W	3.8W	-525C
		1W	2.2W	3.5W	4.4W	3.6W	6.2W	-630C
		1W	2.6W	4.8W	2.2W	4.3W	4.3W	-850C
		0.6W	0.7W	1.2W	1.7W	2.4W	3W	-W00C
TYPE P	No "Type P" standard LED lighting systems in this series							
TYPE S D _{max} = 1/20 Ton max= 2ms		320mA/7.7W	150mA/3.6W	640mA/15W	880mA/21W	1280mA/31W	1200mA/29W	-470S
		320mA/7.7W	150mA/3.6W	640mA/15W	880mA/21W	800mA/19W	1200mA/29W	-525S
		160mA/3.8W	400mA/10W	640mA/15W	880mA/21W	1280mA/31W	1600mA/38W	-630S
		200mA/4.8W	550mA/13W	640mA/15W	500mA/12W	1100mA/24W	1000mA/24W	-850S
		320mA/7.7W	205mA/4.9W	640mA/15W	880mA/21W	1280mA/31W	1600mA/38W	-W00S
	N/A	600mA/14W channel	600mA/14W channel	600mA/14W channel	1708mA/41W channel	1800mA/43W channel	-RGBS	
TYPE i⁶ 		2.4W[10W/1.6W]	3.8W[17W/2.5W]	4.3W[20W/2.8W]	5.8W[27W/3.6W]	8.2W[39W/4.7W]	10W[48W/5.8W]	-470i
		1.9W[10W/1.2W]	3W[17W/1.8W]	3.4W[20W/2W]	4.4W[27W/2.6W]	6.2W[39W/3.6W]	7.7W[48W/4.3W]	-525i
		2.4W[10W/1.4W]	5.5W[17W/3.5W]	6.2W[20W/3.9W]	8.4W[27W/5.2W]	8.2W[39W/6.2W]	13W[48W/6.7W]	-630i
		1.9W[10W/1.4W]	4.1W[24W/2.9W]	6.2W[39W/4.3W]	4.1W[24W/2.9W]	7.7W[48W/5.3W]	7.7W[48W/4.8W]	-850i
		2.4W[10W/1.4W]	3.8W[17W/3W]	4.3W[20W/3.4W]	5.8W[27W/4.4W]	7.4W[39W/5.7W]	9.1W[48W/7W]	-W00i

N/A= Not available

(1) Environmental specifications and iconography legend in additional annex Z1.4 and Z2 respectively.

(2) Prior to manufacturing optional modifications in standard lighting systems. Please, consult the code before ordering (additional annex Z2.1).

(3) Accessories are not-included. More information in accessories section.

(4) iBlueDrive control input wiring specifications in additional annex Z1.2.

(5) Bear in mind that consumption table is only to be used as a guide. To refer to real values, please, consult product label when purchasing.

(6) Values of maximum instantaneous consumption of "Type i" lighting systems in **Powered mode (Strobe mode / Continuous mode)**



BKL SERIES

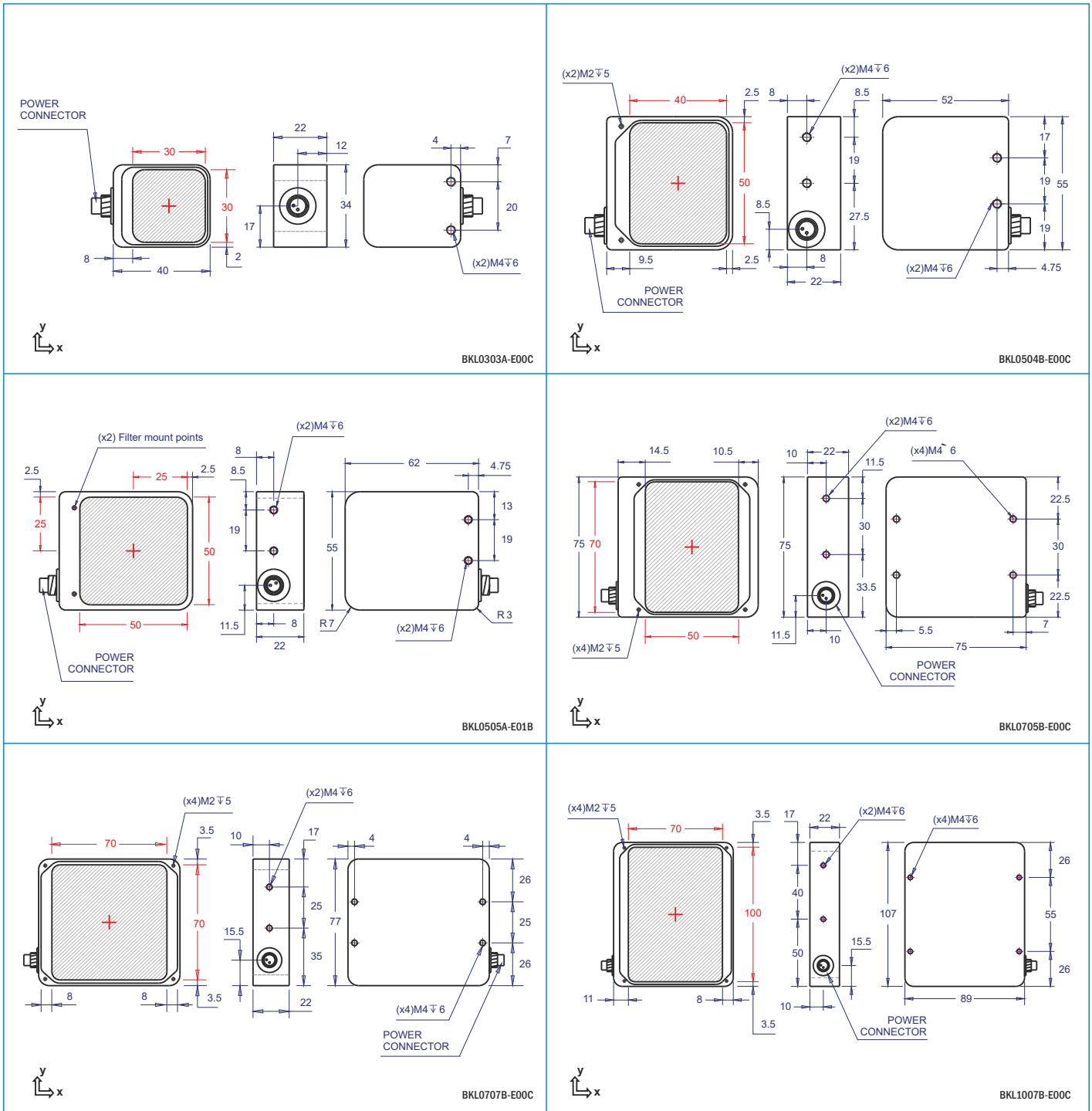

All units in millimeters, if not indicated.



Example of BKL captured image

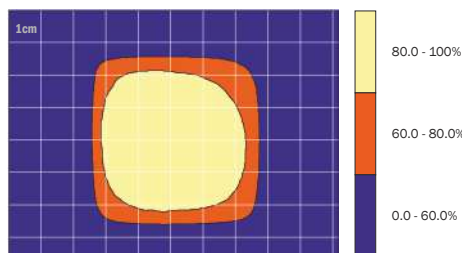

Brightness distribution of BKL0505A-630C

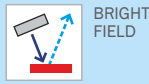
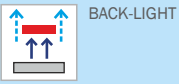

BKL SERIES

Area backlights (2/3) - BKL1010A to BKL2010A

Posterior diffuse lighting system usually design to measure precisely or emphasize light-dark differences by contrast that allows to have good images of object's shape.

Are used to inspect profiles and edges also used for bright fields creation.

Technical specifications¹

Lighting model	BKL1010A	BKL1510A	BKL1515B	BKL1818A	BKL2005A	BKL2010A
Dimensions	116x106x22	116x154x22	169x157x22	194x184x22	66x204x22	116x207x22
Active surface	100x100	100x150	150x150	180x180	50x200	100x200
Weight	305g	435g	620g	770g	370g	515g
IP rating	IP40	IP40	IP40	IP40	IP40	IP40
Mounting holes	(x6)M4I6	(x7)M4I6	(x7)M4I6	(x7)M4I6	(x7)M4I6	(x7)M4I6
Connection (Type C/S)	2P male chassis connector PIN 1 = +24V ±3% PIN 2 = 0V	2P male chassis connector PIN 1 = +24V ±3% PIN 2 = 0V	2P male chassis connector PIN 1 = +24V ±3% PIN 2 = 0V	2P male chassis connector PIN 1 = +24V ±3% PIN 2 = 0V	2P male chassis connector PIN 1 = +24V ±3% PIN 2 = 0V	2P male chassis connector PIN 1 = +24V ±3% PIN 2 = 0V
Power cable (Not-included)	VCB Series	VCB Series	VCB Series	VCB Series	VCB Series	VCB Series
Modifiers²	N/A	N/A	N/A	N/A	N/A	N/A
Accessories³						
iBlueDrive tech.	inline	inline	inline	inline	inline	inline
iBlueDrive connection	3P aerial male inline connector. L= 715mm. PIN 1 = +24V ±8% PIN 2 = 0V PIN 3 = Control ⁴	3P aerial male inline connector. L= 715mm. PIN 1 = +24V ±8% PIN 2 = 0V PIN 3 = Control ⁴	3P aerial male inline connector. L= 715mm. PIN 1 = +24V ±8% PIN 2 = 0V PIN 3 = Control ⁴	3P aerial male inline connector. L= 715mm. PIN 1 = +24V ±8% PIN 2 = 0V PIN 3 = Control ⁴	3P aerial male inline connector. L= 715mm. PIN 1 = +24V ±8% PIN 2 = 0V PIN 3 = Control ⁴	3P aerial male inline connector. L= 715mm. PIN 1 = +24V ±8% PIN 2 = 0V PIN 3 = Control ⁴
iBlueDrive power cable (Not-included)	VCC Series	VCC Series	VCC Series	VCC Series	VCC Series	VCC Series
iBlueDrive accessories³						

Instantaneous consumption⁵ (max.)

*WT

Lighting model	BKL1010A	BKL1510A	BKL1515B	BKL1818A	BKL2005A	BKL2010A		
TYPE C 24VDC		7.7W	11W	16W	26W	7.7W	-470C	
		6.1W	6.5W	9.5W	16W	5.4W	-525C	
		7W	7.8W	13W	17W	4.6W	-630C	
		10W	12W	15W	27W	7.6W	-850C	
		4.8W	6.8W	10W	16W	4.8W	-W00C	
TYPE P	No "Type P" standard LED lighting systems in this series							
TYPE S D _{max} = 1/20 Ton max= 2ms		1920mA/46W	2700mA/65W	3960mA/95W	6480mA/156W	1920mA/46W	4800mA/115W	-470S
		1920mA/46W	2700mA/65W	3960mA/95W	6480mA/156W	1920mA/46W	4800mA/115W	-525S
		2560mA/61W	3600mA/86W	5280mA/127W	8640mA/207W	2560mA/61W	6400mA/154W	-630S
		2400mA/58W	2700mA/65W	4620mA/111W	6600mA/158W	1760mA/42W	4400mA/106W	-850S
		2560mA/61W	3600mA/86W	5280mA/127W	8640mA/207W	2560mA/61W	6400mA/154W	-W00S
	3000mA/72W channel	4500mA/108W channel	6600mA/158W channel	9000mA/216W channel	2700mA/65W channel	7800mA/187W channel	-RGBS	
TYPE i⁶ 		16W[48W/8.2W]	12W[96W/8W]	24W[96W/12W]	21W[96W/11W]	16W[48W/8.2W]	24W[96W/12W]	-470i
		12W[48W/6.6W]	10W[96W/7W]	24W[96W/12W]	21W[96W/11W]	8.2W[48W/5.9W]	24W[96W/12W]	-525i
		19W[48W/9.7W]	18W[96W/12W]	21W[96W/11W]	21W[96W/11W]	14W[48W/9.7W]	24W[96W/12W]	-630i
		18W[48W/11W]	17W[48W/11W]	18W[96W/13W]	24W[96W/12W]	12W[48W/7.4W]	24W[96W/12W]	-850i
		16W[48W/8.9W]	17W[48W/11W]	21W[96W/15W]	24W[96W/12W]	15W[48W/7.6W]	24W[96W/12W]	-W00i

(1) Environmental specifications and iconography legend in additional annex Z1.4 and Z2 respectively.

(2) Prior to manufacturing optional modifications in standard lighting systems. Please, consult the code before ordering (additional annex Z2.1).

(3) Accessories are not-included. More information in accessories section.

(4) iBlueDrive control input wiring specifications in additional annex Z1.2.

(5) Bear in mind that consumption table is only to be used as a guide. To refer to real values, please, consult product label when purchasing.

(6) Values of maximum instantaneous consumption of "Type i" lighting systems in **Powered mode (Strobe mode / Continuous mode)**



BKL SERIES

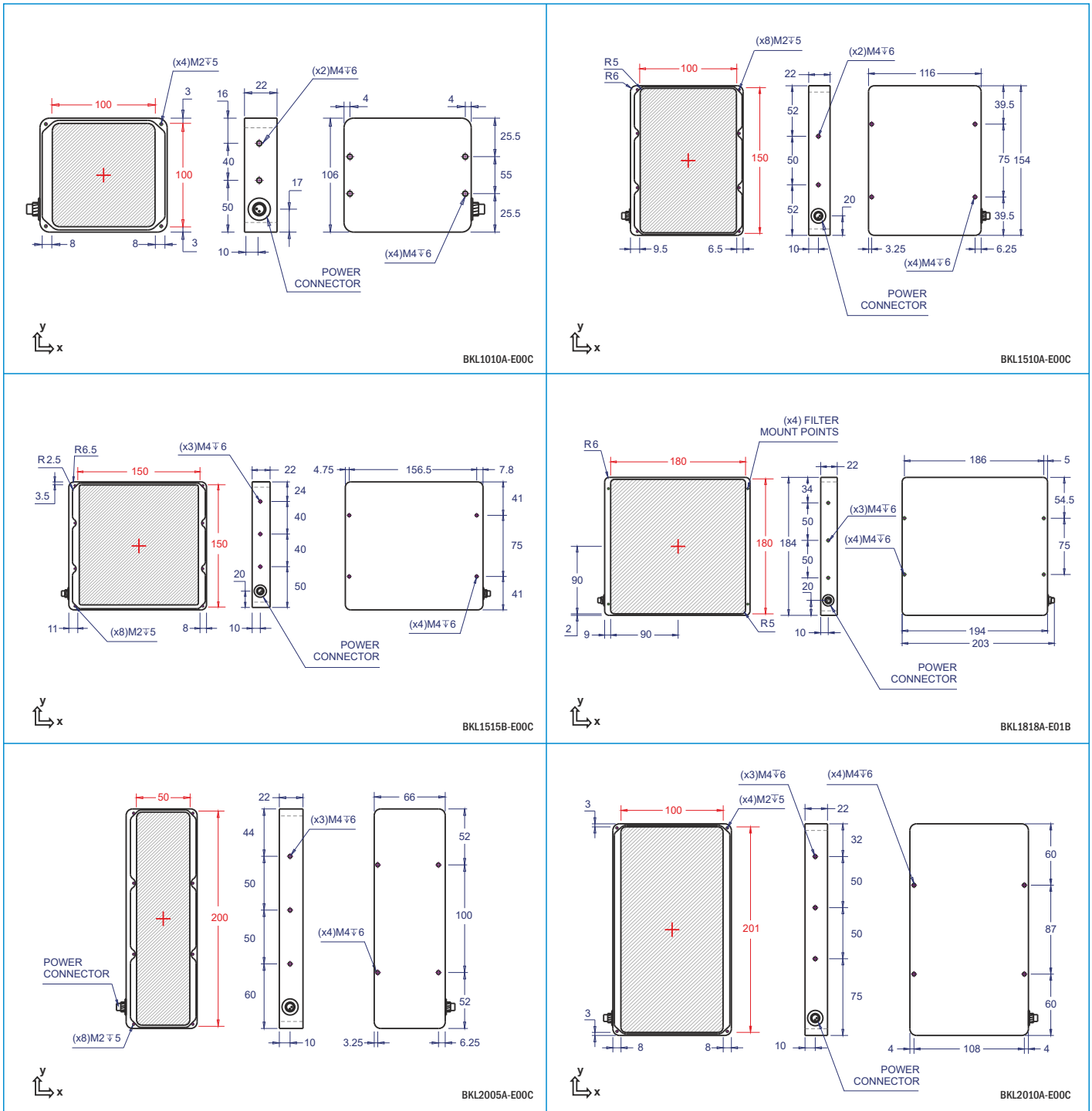

All units in millimeters, if not indicated.

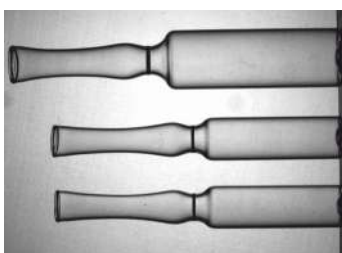

Example of BKL captured image

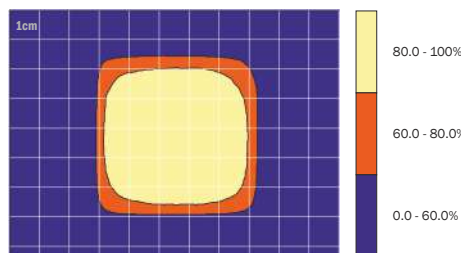

Brightness distribution of BKL1010A-630C

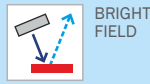

BKL SERIES

Area backlights (3/3) - BKL2222A to BKL4005A

Posterior diffuse lighting system usually design to measure precisely or emphasize light-dark differences by contrast that allows to have good images of object's shape.

Are used to inspect profiles and edges also used for bright fields creation.

Technical specifications¹

Lighting model	BKL2222A	BKL2515B	BKL2518A	BKL3005A	BKL4005A
Dimensions	239x227x22	169x257x22	198x255x22	69x304x22	66x404x22
Active surface	220x220	150x250	180x250	50x300	50x400
Weight	1195g	1015g	1125g	585g	692g
IP rating	IP40	IP40	IP40	IP40	IP40
Mounting holes	(x10)M4I6	(x10)M4I6	(x10)M4I6	(x10)M4I6	(x13)M4I6
Connection (Type C/S)	2P male chassis connector PIN 1 = +24V ±3% PIN 2 = 0V	2P male chassis connector PIN 1 = +24V ±3% PIN 2 = 0V	2P male chassis connector PIN 1 = +24V ±3% PIN 2 = 0V	2P male chassis connector PIN 1 = +24V ±3% PIN 2 = 0V	2P male chassis connector PIN 1 = +24V ±3% PIN 2 = 0V
Power cable (Not-included)	VCB Series	VCB Series	VCB Series	VCB Series	VCB Series
Modifiers²	N/A	N/A	N/A	N/A	N/A
Accessories³					
iBlueDrive tech.	inline	inline	N/A	inline	inline
iBlueDrive connection	3P aerial male inline connector. L= 715mm. PIN 1 = +24V ±8% PIN 2 = 0V PIN 3 = Control	3P aerial male inline connector. L= 715mm. PIN 1 = +24V ±8% PIN 2 = 0V PIN 3 = Control ⁴	N/A	3P aerial male inline connector. L= 715mm. PIN 1 = +24V ±8% PIN 2 = 0V PIN 3 = Control	3P aerial male inline connector. L= 715mm. PIN 1 = +24V ±8% PIN 2 = 0V PIN 3 = Control ⁴
iBlueDrive power cable (Not-included)	VCC Series	VCC Series	N/A	VCC Series	VCC Series
iBlueDrive accessories³			N/A		

Instantaneous consumption⁵ (max.)

*WT

Lighting model	BKL2222A	BKL2515B	BKL2518A	BKL3005A	BKL4005A		
TYPE C 24VDC		35W	21W	26W	10W	16W	-470C
		21W	13W	28W	6.8W	11W	-525C
		31W	19W	19W	7W	9.5W	-630C
		23W	24W	24W	11W	14W	-850C
		22W	17W	25W	6.2W	10W	-W00C
TYPE P	No "Type P" standard LED lighting systems in this series						
TYPE S D _{max} = 1/20 Ton max= 2ms		8640mA/207W	6720mA/161W	13200mA/317W	2460mA/59W	3900mA/94W	-470S
		8640mA/207W	6720mA/161W	13200mA/317W	2460mA/59W	3900mA/94W	-525S
		11520mA/276W	8960mA/215W	13200mA/317W	3280mA/79W	5200mA/125W	-630S
		7920mA/190W	6710mA/161W	8250mA/198W	2640mA/69W	3300mA/79W	-850S
		11520mA/276W	8960mA/215W	13200mA/317W	3280mA/69W	5200mA/125W	-W00S
	14400mA/346W channel	11100mA/266W channel	5940mA/143W channel	4500mA/108W channel	N/A	-RGS	
TYPE i⁶ 		24W[96W/12W]	24W[96W/12W]	N/A	15W[96W/10W]	24W[96W/12W]	-470i
		24W[96W/12W]	24W[96W/12W]	N/A	15W[96W/10W]	16W[96W/11W]	-525i
		24W[96W/14W]	24W[96W/12W]	N/A	18W[48W/12W]	24W[96W/12W]	-630i
		20W[96W/10W]	24W[96W/12W]	N/A	15W[48W/10W]	24W[96W/12W]	-850i
		25W[96W/13W]	24W[96W/12W]	N/A	15W[48W/10W]	24W[96W/12W]	-W00i

N/A= Not available

(1) Environmental specifications and iconography legend in additional annex Z1.4 and Z2 respectively.

(2) Prior to manufacturing optional modifications in standard lighting systems. Please, consult the code before ordering (additional annex Z2.1).

(3) Accessories are not-included. More information in accessories section.

(4) iBlueDrive control input wiring specifications in additional annex Z1.2.

(5) Bear in mind that consumption table is only to be used as a guide. To refer to real values, please, consult product label when purchasing.

(6) Values of maximum instantaneous consumption of "Type i" lighting systems in **Powered mode (Strobe mode / Continuous mode)**



BKL SERIES

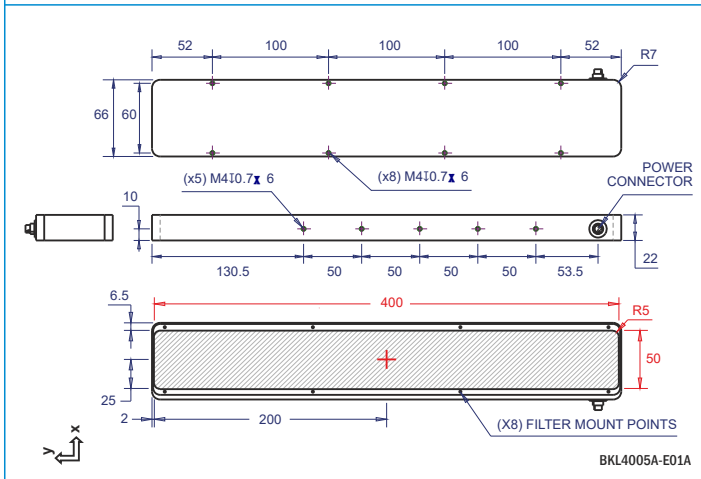
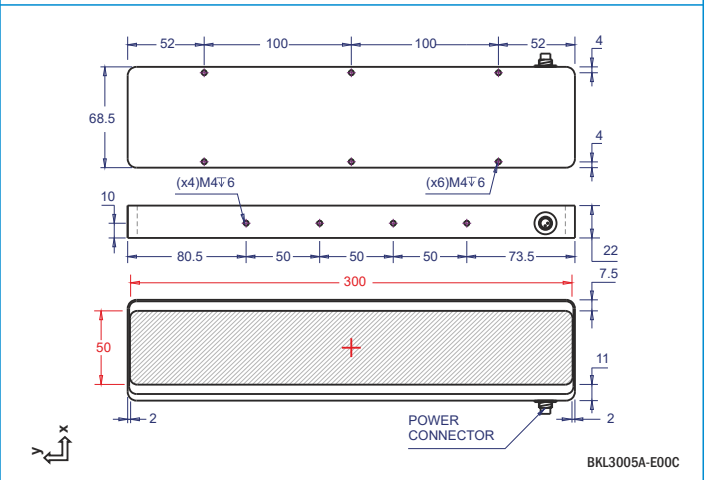
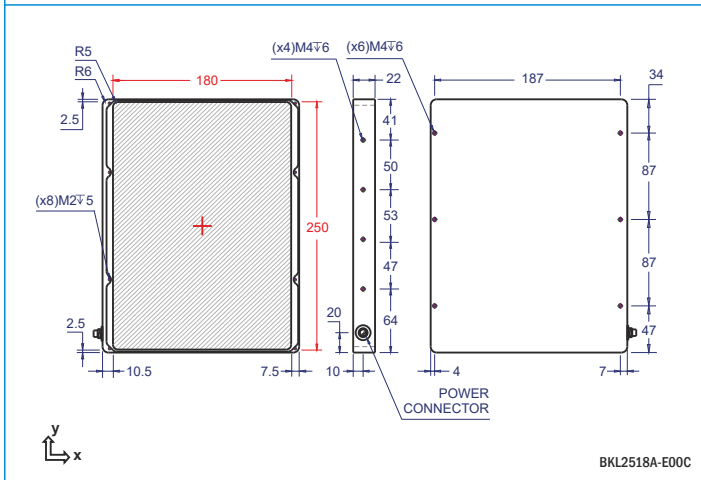
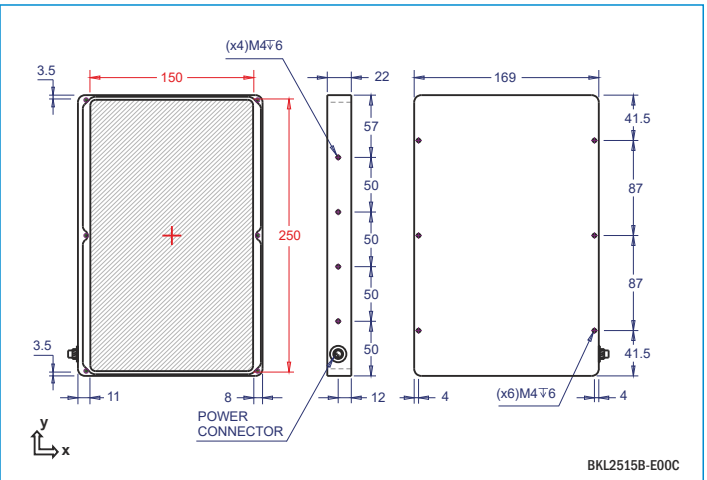
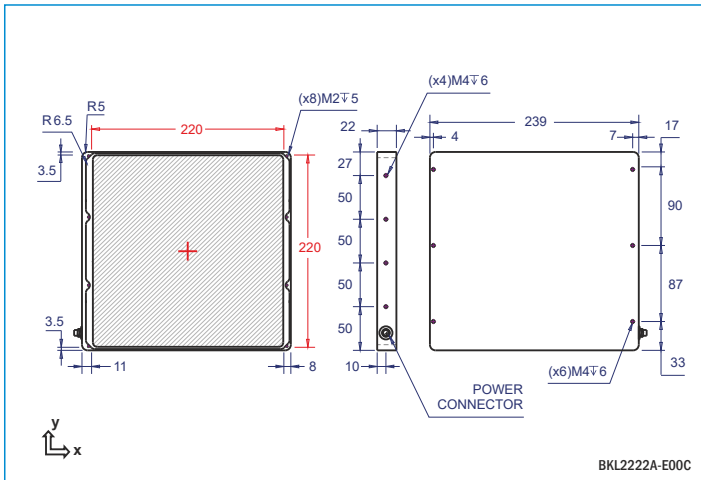

All units in millimeters, if not indicated.



Example of BKL captured image

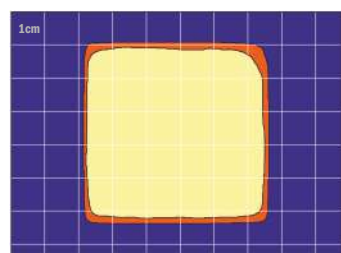

Brightness distribution of BKL2222A-630C

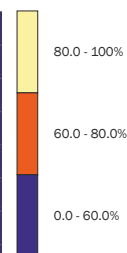

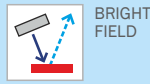
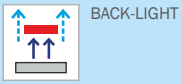

BKM SERIES

Large area backlights

Customizable area backlights specially designed for giving solution to those applications that can not be solved through BKL backlights. Customizable in increments of 50mm in both sides.

An option of adding a hole in the middle is available for all sizes (/H = 42mm /H1 = 65mm)

Technical specifications¹

Lighting model	BKMaabb*A	BKMaabb*A/H	BKMaabb*A/H1	
				* Lighting model = bb KMaabbA L1 = aa x 10 mm L2 = bb x 10 mm
Dimensions	Length (L) = L1 + 32 Width = L2 + 32	Length (L) = L1 + 32 Width = L2 + 32 Inner Hole = 42	Length (L) = L1 + 32 Width = L2 + 32 Inner Hole = 65	
Active surface	Length (L) = L1 Width = L2	Length (L) = L1 Width = L2	Length (L) = L1 Width = L2	
Weight	N/A	N/A	N/A	
IP rating	IP40	IP40	IP40	
Mounting holes	(x8)M4I6	(x8)M4I6	(x8)M4I6	
Connection (Type C/S)	Pre-cabled with flying leads 2X0.5mm ² Length=3m BN = +24V ±3% BU = 0V	Pre-cabled with flying leads 2X0.5mm ² Length=3m BN = +24V ±3% BU = 0V	Pre-cabled with flying leads 2X0.5mm ² Length=3m BN = +24V ±3% BU = 0V	
Modifiers ²		Modifier integrated (45mm hole)	Modifier integrated (62mm hole)	
Accessories ³				
iBlueDrive tech.	NO	NO	NO	

(* Customizable lighting system composed by increments of 50mm in any of its sides. The required dimension for each application is assembled preserving light homogeneity. The lighting model name will depend on its length and width as it is shown below:

Lighting model	L1 = Active surface Length	L2 = Active surface Width
BKM 4060 A	40 x 10 = 400 mm	60 x 10 = 600 mm
BKM 3575 A	35 x 10 = 350 mm	75 x 10 = 750 mm
BKM aa bbA	aa x 10 = L1 mm	bb x 10 = L2 mm

Instantaneous consumption⁴ (max.)

*WT

Lighting model	BKMaabb*A	BKMaabb*A/H	BKMaabb*A/H1	
TYPE C 24VDC	7.6W x (aa x bb /100)	7.6W x (aa x bb /100) - 1.9W	7.6W x (aa x bb /100) - 2.1W	-470C
	7.6W x (aa x bb /100)	7.6W x (aa x bb /100) - 1.9W	7.6W x (aa x bb /100) - 2.1W	-525C
	4.2W x (aa x bb /100)	4.2W x (aa x bb /100) - 1.9W	4.2W x (aa x bb /100) - 2.1W	-630C
	2.1W x (aa x bb /100)	2.1W x (aa x bb /100) - 1.9W	2.1W x (aa x bb /100) - 2.1W	-850C
	7.6W x (aa x bb /100)	7.6W x (aa x bb /100) - 1.9W	7.6W x (aa x bb /100) - 2.1W	-W00C
TYPE P	No 'Type P' standard LED lighting systems in this series			
TYPE S Dmax= 1/2o Ton max= 2ms	34W x (aa x bb /100)	34W x (aa x bb /100) - 1.9W	34W x (aa x bb /100) - 2.1W	-470S
	34W x (aa x bb /100)	34W x (aa x bb /100) - 1.9W	34W x (aa x bb /100) - 2.1W	-525S
	34W x (aa x bb /100)	34W x (aa x bb /100) - 1.9W	34W x (aa x bb /100) - 2.1W	-630S
	21W x (aa x bb /100)	21W x (aa x bb /100) - 1.9W	21W x (aa x bb /100) - 2.1W	-850S
	34W x (aa x bb /100)	34W x (aa x bb /100) - 1.9W	34W x (aa x bb /100) - 2.1W	-W00S
TYPE i	No 'Type i' standard LED lighting systems in this series			

(1) Environmental specifications and iconography legend in additional annex Z1.4 and Z2 respectively.

(2) Prior to manufacturing optional modifications in standard lighting systems. Please, consult the code before ordering (additional annex Z2.1).

(3) Accessories are not-included. More information in accessories section.

(4) Bear in mind that consumption table is only to be used as a guide. To refer to real values, please, consult product label when purchasing.



BKM SERIES

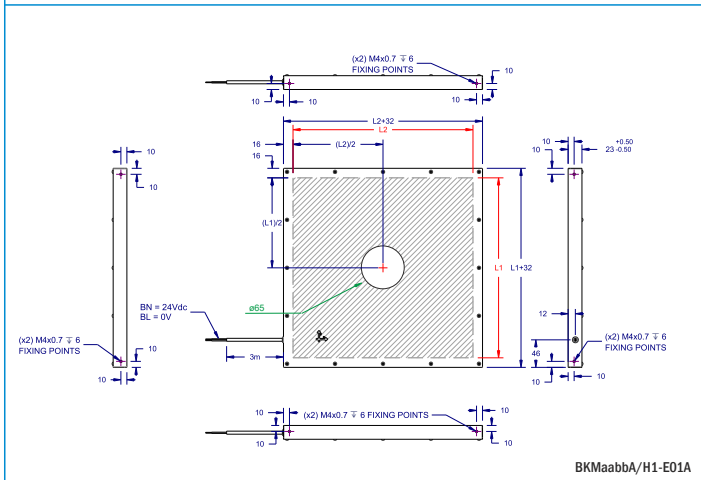
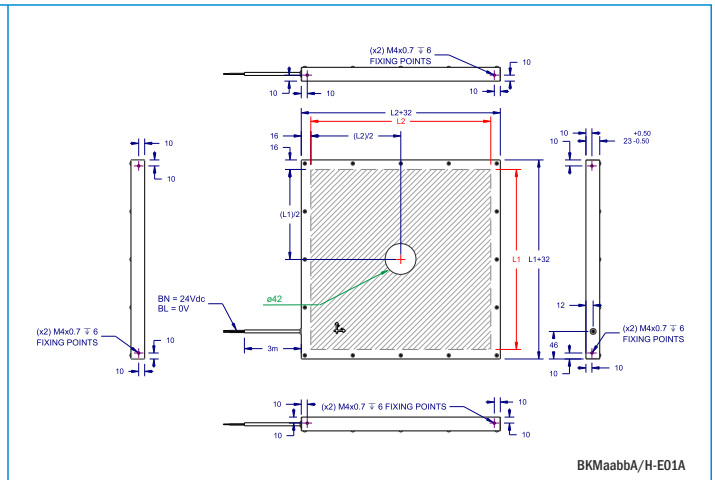
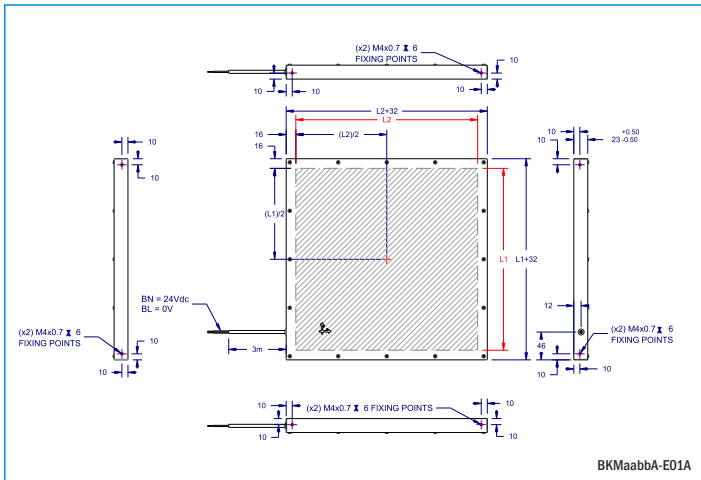

All units in millimeters, if not indicated.

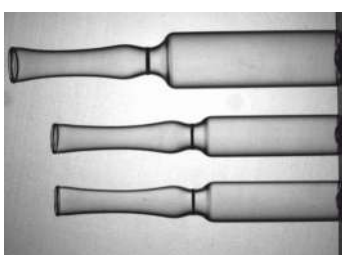

Example of BKM captured image

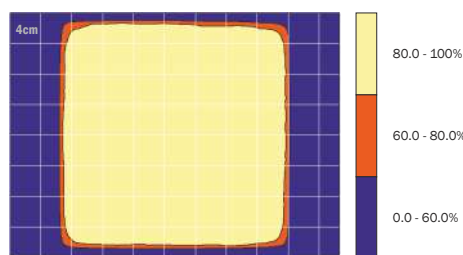

Brightness distribution of BKM array section at 630C

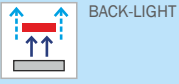

BKN SERIES

Linear backlights

Backlight system for linescan sensors in applications that inspect materials manufactured in continuous such as paper, cloth, glass or wire mesh. The light produced by BKN system is very intense, diffuse and homogeneous to inspect object's shape, transmittance or impurities.

Technical specifications¹

Lighting model	BKN0nn*0A	BKN2nn*0A
Dimensions	Length (L) = 100 x nn + 30 Width = 29.5	Length (L) = 100 x nn + 50 Width = 36
Active surface	Length (L) = 100 x nn Width = 5	Length (L) = 100x nn Width = 16
Weight	60g + (97.5g x nn)	90g + (440g x nn/2)
IP rating	IP40	IP40
Mounting holes	nn x M3I5	T-nut 8mm along aluminium profile
Connection (Type C)	2P aerial male connector. L= 150mm. PIN 1 = +24V ±3% PIN 2 = 0V	2P Flying leads L= 3000m. PIN 1 = +24V ±3% PIN 2 = 0V
Power cable (Not-included)	VCB Series	N/A
Modifiers²	N/A	N/A
Accessories³	N/A	N/A
iBlueDrive tech.	N/A	N/A

(*) Customizable lighting system composed by segments of 200mm of light emission window. The required length for each application is assembled from manufacturing preserving light homogeneity. The lighting model name will depend on the number of segments and will be composed as it is shown in the table below:

Lighting model	nn	L = n x 100mm (Length)
BKN0020A / BKN2020A	02	200
BKN0040A / BKN2040A	04	400
BKN0nn0A / BKN2nn0A	nn	(nn x 100)
BKN0300A / BKN2300A	30	3000

Instantaneous consumption⁴ (max.)

Lighting model	BKN0nn0A	BKN2nn0A	*WT	
TYPE C 24VDC		2.65W x nn	13.75W x nn	-470C
		2.65W x nn	13.75W x nn	-525C
		2.05W x nn	11.6W x nn	-630C
		2.35W x nn	N/A	-850C
		2.65W x nn	13.75W x nn	-W00C
TYPE P	No "Type P" standard LED lighting systems in this series			
TYPE S	No "Type S" standard LED lighting systems in this series			
TYPE i	No "Type i" standard LED lighting systems in this series			

(1) Environmental specifications and iconography legend in additional annex Z1.4 and Z2 respectively.

(2) Prior to manufacturing optional modifications in standard lighting systems. Please, consult the code before ordering (additional annex Z2.1).

(3) Accessories are not-included. More information in accessories section.

(4) Bear in mind that consumption table is only to be used as a guide. To refer to real values, please, consult product label when purchasing.



BKN SERIES

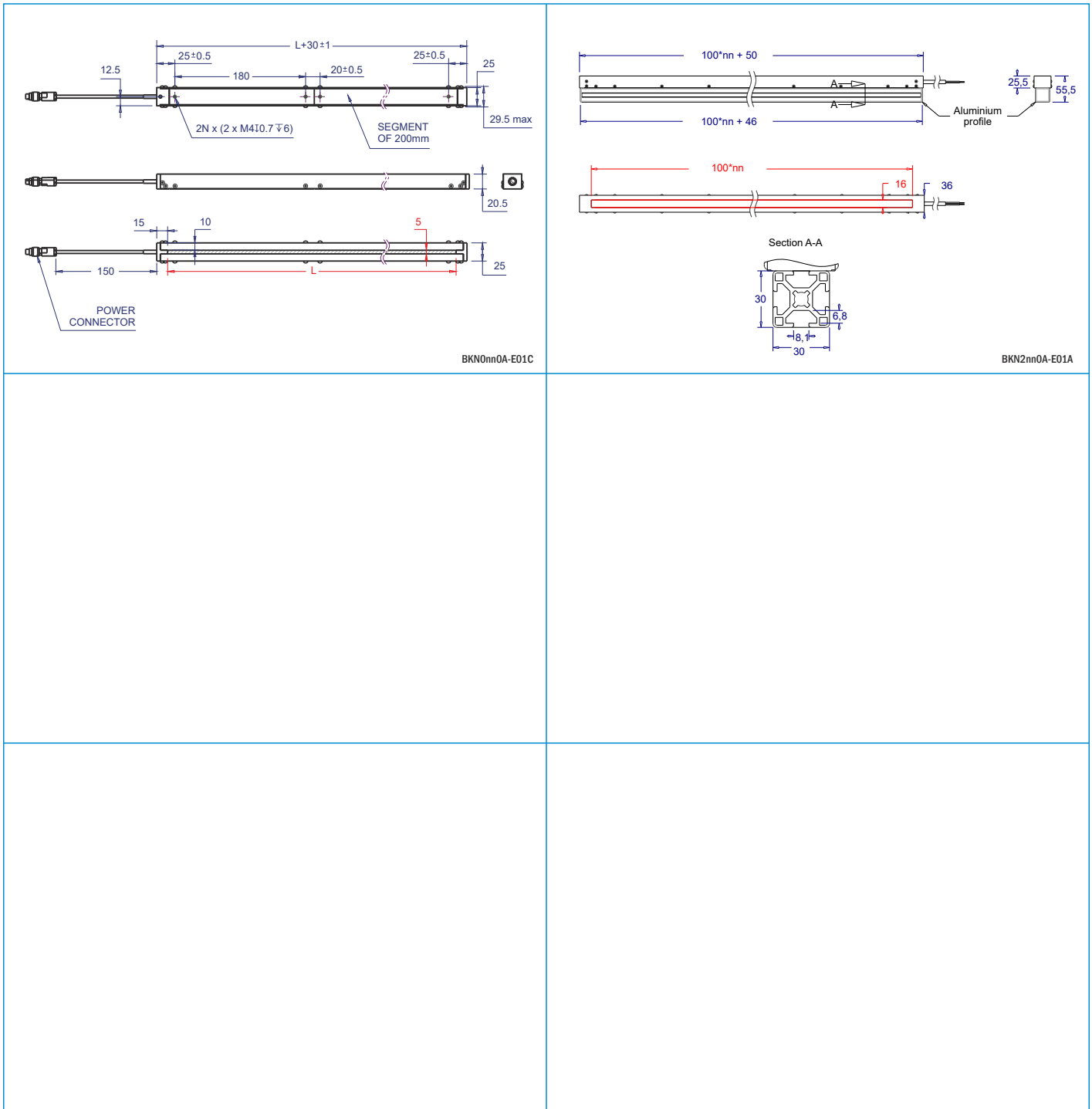

All units in millimeters, if not indicated.



Example of BKN captured image

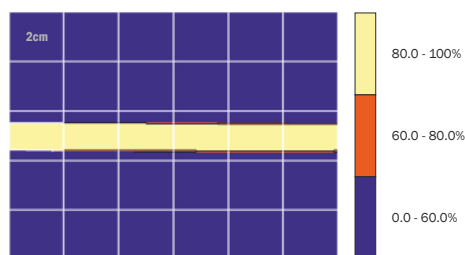

Brightness distribution of BKN array section at 630C

DKL SERIES

Darkfield lights



















Generally used to illuminate objects from camera axis with a small angle, emphasizing small cracks, lines and reliefs of the piece to be inspected and also eliminating the brightness and shadows. This series of direct light darkfields is specially thought for providing a huge amount of light to highlight edges and possible variations in height when taking photographs.

► Technical specifications¹

Lighting model	DKL1813A	DKL2418A	DKL3223A	DKL4130A	DKL5650BA
					
Dimensions	188x188x13	240x240x13	337x337x13	394x394x13	570x570x10
Inner Ø	130	180	230	300	500
RWD (mm)	<10	<15	<20	<20	<20
Weight	340g	430g	930g	1180g	
IP rating	IP40	IP40	IP40	IP40	IP40
Mounting holes	(x8)ø4ITHRU	(x8)ø4ITHRU	(x8)ø4ITHRU	(x8)ø5ITHRU	(x8)ø4.5ITHRU
Connection (Type C/P/S)	BN = +24V ±3% BU = 0V	BN = +24V ±3% BU = 0V	BN = +24V ±3% BU = 0V	BN = +24V ±3% BU = 0V	BN = +24V ±3% BU = 0V
Power cable	Pre-cabled with flying leads 2x0.5mm ² Length=1.8m	Pre-cabled with flying leads 2x0.5mm ² Length=1.8m	Pre-cabled with flying leads 2x0.5mm ² Length=1.8m	Pre-cabled with flying leads 2x0.5mm ² Length=1.8m	Pre-cabled with flying leads 2x0.5mm ² Length=1.8m
Modifiers²					
Accessories³					
iBlueDrive tech.	inline	inline	N/A	N/A	inline
iBlueDrive connection	3P aerial male inline connector. L= 715mm. PIN 1 = +24V ±8% PIN 2 = 0V PIN 3 = Control ⁴	3P aerial male inline connector. L= 715mm. PIN 1 = +24V ±8% PIN 2 = 0V PIN 3 = Control ⁴	N/A	N/A	3P aerial male inline connector. L= 715mm. PIN 1 = +24V ±8% PIN 2 = 0V PIN 3 = Control ⁴
iBlueDrive power cable (Not-included)	VCC Series	VCC Series	N/A	N/A	VCC Series
iBlueDrive accessories³			N/A	N/A	

► Instantaneous consumption⁵ (max.)

*WT

Lighting model	DKL1813A	DKL2418A	DKL3223A	DKL4130A	DKL4130A		
TYPE C 24VDC		5W	7.6W	20W	27W	21W	-470C
		5W	7.6W	20W	27W	21W	-525C
		5W	5W	18W	20W	15W	-630C
		2.9W	5.3W	12W	19W	12W	-850C
TYPE P D _{max} = 1/2 Ton max= 60s		6.4W	9.5W	25W	34W	21W	-400P
		6.4W	9.5W	25W	34W	21W	-W00P
TYPE S D _{max} = 1/20 Ton max= 2ms		1320mA/32W	1585mA/38W	5280mA/127W	7040mA/169W	3695mA/89W	-400S
		1320mA/32W	1585mA/38W	5280mA/127W	7040mA/169W	3695mA/89W	-470S
		825mA/20W	990mA/24W	3300mA/79W	4400mA/106W	2310mA/89W	-525S
		880mA/21W	1585mA/38W	3520mA/84W	5630mA/135W	3695mA/89W	-630S
		1045mA/25W	1880mA/45W	4180mA/100W	6690mA/161W	4390mA/105W	-850S
		1320mA/32W	1585mA/38W	5280mA/127W	5630mA/135W	880mA/21W	-W00S
TYPE i⁶ 		6.2W[29W/3.4W]	9.1W[44W/4.8W]	N/A	N/A	21W[96W/11W]	-400i
		5.7W[29W/3.9W]	8.3W[44W/5.7W]	N/A	N/A	19W[96W/13W]	-470i
		4.8W[15W/2.8W]	7W[22W/3.9W]	N/A	N/A	16W[96W/8.5W]	-525i
		9.1W[29W/6.2W]	13W[44W/9.1W]	N/A	N/A	31W[96W/21W]	-630i
		8.4W[29W/4.8W]	12W[44W/7.0W]	N/A	N/A	28W[96W/11W]	-850i
		6.2W[29W/3.4W]	9.1W[44W/4.8W]	N/A	N/A	21W[96W/11W]	-W00i

N/A= Not available

(1) Environmental specifications and iconography legend in additional annex Z1.4 and Z2 respectively.

(2) Prior to manufacturing optional modifications in standard lighting systems. Please, consult the code before ordering (additional annex Z2.1).

(3) Accessories are not-included. More information in accessories section.

(4) iBlueDrive control input wiring specifications in additional annex Z1.2.

(5) Bear in mind that consumption table is only to be used as a guide. To refer to real values, please, consult product label when purchasing.

(6) Values of maximum instantaneous consumption of 'Type i' lighting systems in **Powered mode (Strobe mode / Continuous mode)**



DKL SERIES

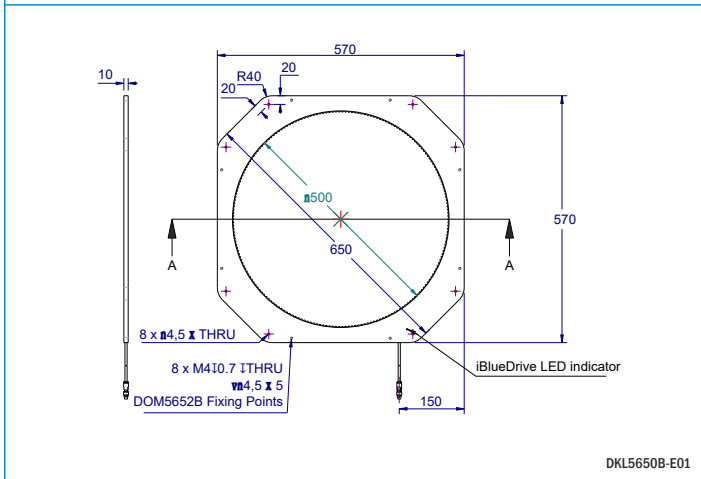
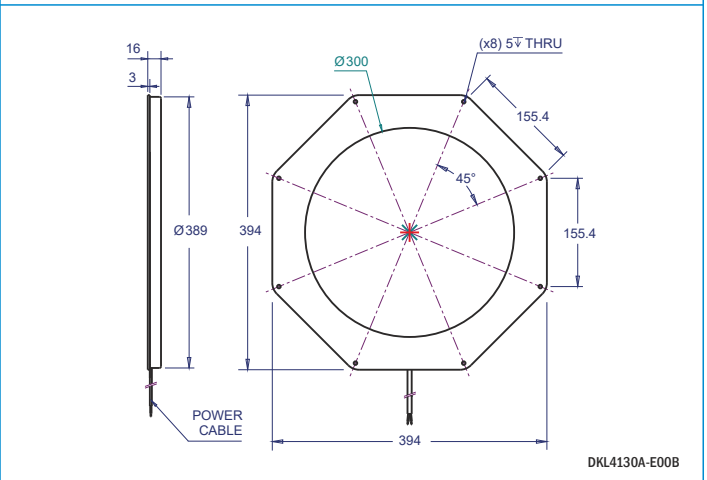
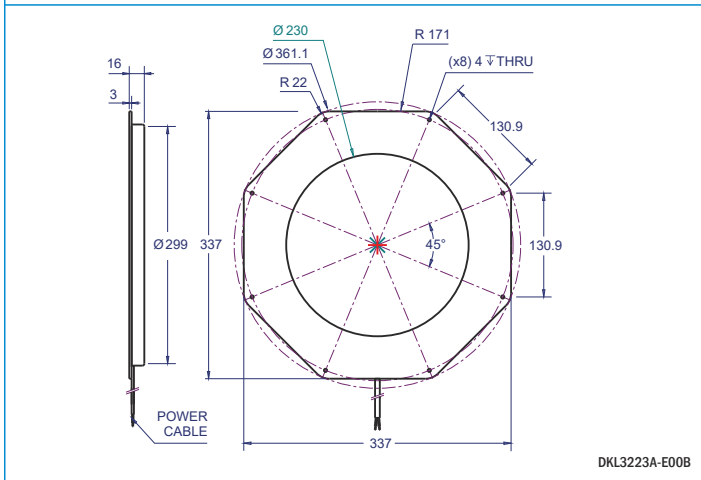
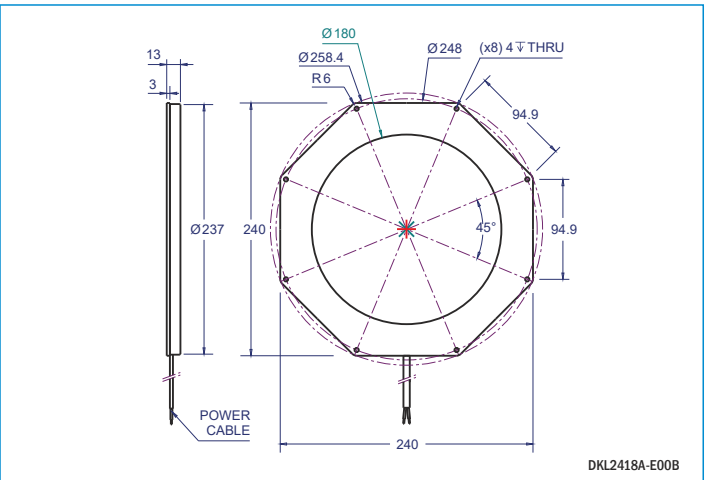
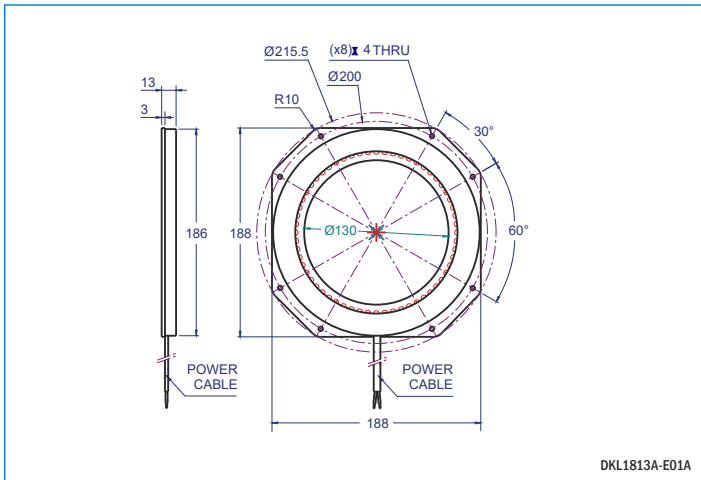

All units in millimeters, if not indicated.











Example of DKL captured image

DOL SERIES

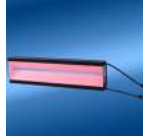
Linear dome lights

Diffuse and linear domes for linear cameras use. They provide powerful and uniform light with no shades along the whole scanning line. The independent control of their two halves plus the flexibility of iBlueDrive technology to control LED lights gives this series the best adaptability in adjusting lighting parameters.











► Technical specifications¹

Lighting model	DOL0100A*	DOL0250A*	DOL0400A*
			
Dimensions	104x103x38	254x103x38	404x103x38
Active surface	(x2) 100x35	(x2) 250x35	(x2) 400x35
RWD (mm)	<20	<20	<20
Weight	350g	788g	1225g
IP rating	IP40	IP40	IP40
Mounting holes	(x2)M4I5	(x4)M4I5	(x5)M4I5
Connection (Type C)	(x2) 3P aerial male connector. L= 150mm. PIN 1 = +24V ±8% PIN 2 = 0V PIN 3 = Control ²	(x2) 3P aerial male connector. L= 150mm. PIN 1 = +24V ±8% PIN 2 = 0V PIN 3 = Control ²	(x2) 3P aerial male connector. L= 150mm. PIN 1 = +24V ±8% PIN 2 = 0V PIN 3 = Control ²
Power cable	(x2) VCC Series	(x2) VCC Series	(x2) VCC Series
Modifiers³			
Accessories⁴	N/A	N/A	N/A
iBlueDrive tech.	Built-in	N/A	N/A
iBlueDrive connection	3P aerial male inline connector. L= 715mm. PIN 1 = +24V ±8% PIN 2 = 0V PIN 3 = Control ⁵	N/A	N/A
iBlueDrive power cable (Not-included)	VCC Series	N/A	N/A
iBlueDrive accessories³	  	N/A	N/A

(*) It has a LED indicator that informs you about the device state. This LED is normally OFF. In **red**, it indicates the overheating of the system. The system will switch off until it is cool again.

► Instantaneous consumption⁶ (max.)

*WT

Lighting model		DOL0100A	DOL0250A	DOL0400A	
TYPE C 24VDC		15W	29W	29W	-470C
		15W	29W	29W	-525C
		15W	21W	42W	-630C
		15W	24W	24W	-850C
		15W	29W	29W	-W00C
TYPE P		No "Type P" standard LED lighting systems in this series			
TYPE S		No "Type S" standard LED lighting systems in this series			
TYPE i⁷ 		24W[48W/12W]	N/A	N/A	-470i
		24W[48W/12W]	N/A	N/A	-525i
		19W[48W/12W]	N/A	N/A	-630i
		24W[48W/12W]	N/A	N/A	-850i
		24W[48W/12W]	N/A	N/A	-W00i

N/A= Not available

(1) Environmental specifications and iconography legend in additional annex Z1.4 and Z2 respectively.

(2) Control input specifications of DOL series in additional annex Z1.1.

(3) Prior to manufacturing optional modifications in standard lighting systems. Please, consult the code before ordering (additional annex Z2.1).

(4) Accessories are not-included. More information in accessories section.

(5) iBlueDrive control input wiring specifications in additional annex Z1.2.

(6) Bear in mind that consumption table is only to be used as a guide. To refer to real values, please, consult product label when purchasing.

(7) Values of maximum instantaneous consumption of "Type i" lighting systems in **Powered mode [Strobe mode / Continuous mode]**



DOL SERIES

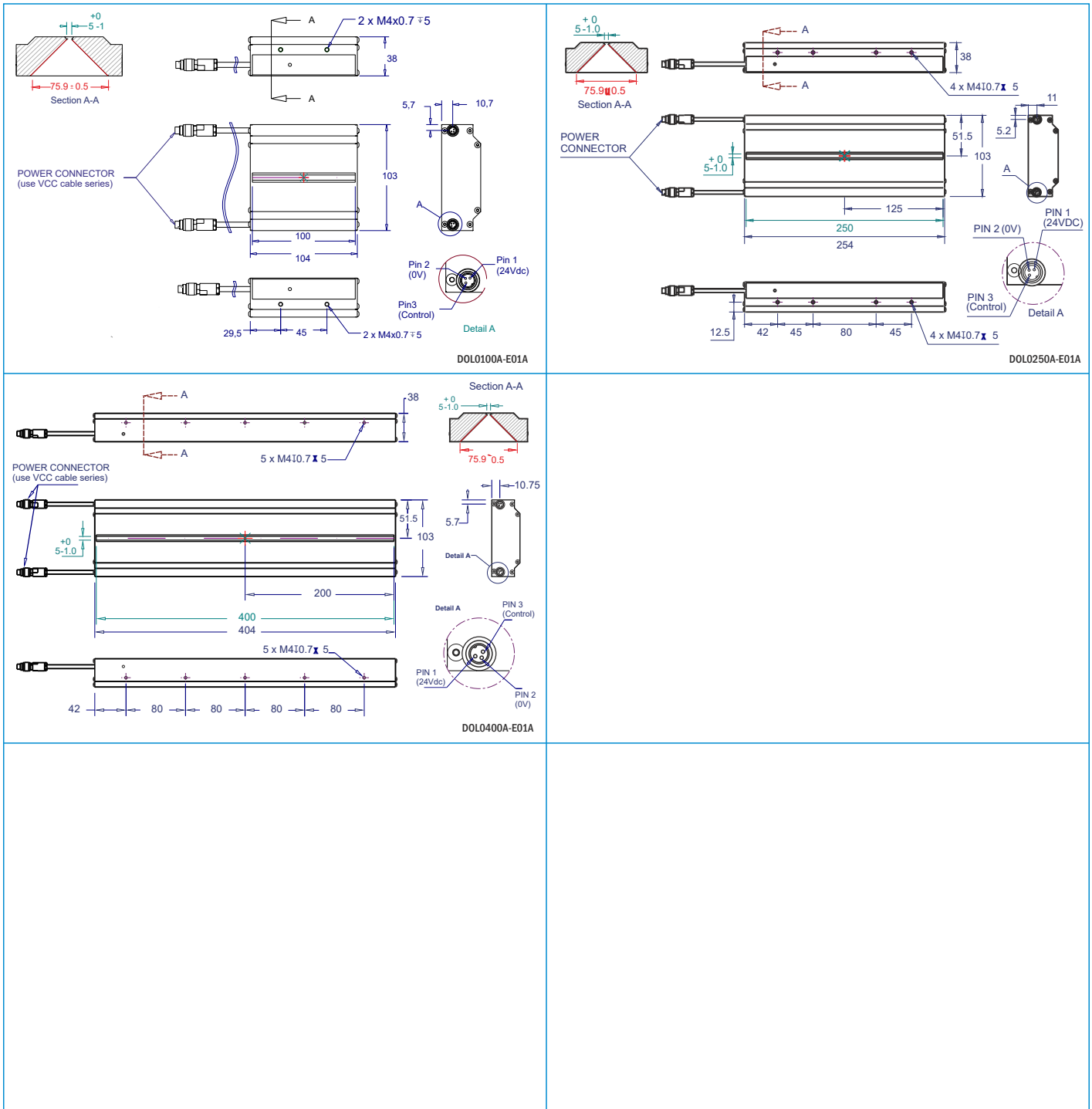

All units in millimeters, if not indicated.

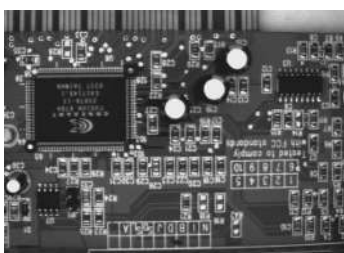

Example of DOL captured image

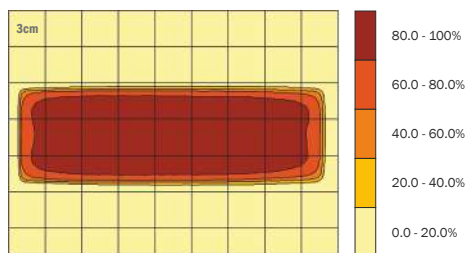

Brightness distribution of DOL0250A-630C@5mm

DOM SERIES

Dome lights (1/2) - DOM0906A to DOM4127A

'Cloudy day' lighting system. Illuminate objects from camera axis to all directions, providing great amount of uniform light that eliminates brightness and shadows. It is one of the most effective device in equaling the surface to illuminate.

This lighting type is ideal for shinning and curved surfaces.

Technical specifications¹

Lighting model	DOM0906A	DOM1410A	DOM1613A	DOM2414A	DOM3218A	DOM4127A
Dimensions	96x96x50	145x145x72	170x170x86	259x259x100	337x337x116	425x425x181
Bottom Ø	55	100	125	144	180	265
RWD (mm)	<20	<20	<20	<20	<20	<20
Weight	139g	274g	391g	690g	1240g	2180g
IP rating	IP00	IP00	IP00	IP00	IP00	IP00
Mounting holes	((x8)ø3ITHRU	((x8)ø3ITHRU	((x8)ø3ITHRU	(x8)ø4ITHRU	(x8)ø4ITHRU	(x8)ø4ITHRU
Connection (Type C/S)	BN = +24V ±3% BU = 0V	BN = +24V ±3% BU = 0V	BN = +24V ±3% BU = 0V	BN = +24V ±3% BU = 0V	BN = +24V ±3% BU = 0V	BN = +24V ±3% BU = 0V
Power cable	Pre-cabled with flying leads 2x0.5mm ² Length=1.8m	Pre-cabled with flying leads 2x0.5mm ² Length=1.8m	Pre-cabled with flying leads 2x0.5mm ² Length=1.8m	Pre-cabled with flying leads 2x0.5mm ² Length=1.8m	Pre-cabled with flying leads 2x0.5mm ² Length=1.8m	Pre-cabled with flying leads 2x0.5mm ² Length=1.8m
Modifiers ²						
Accessories ³						
iBlueDrive tech.	inline	inline	inline	inline	N/A	N/A
iBlueDrive connection	3P aerial male inline connector. L= 715mm. PIN 1 = +24V ±8% PIN 2 = 0V PIN 3 = Control ⁴	3P aerial male inline connector. L= 715mm. PIN 1 = +24V ±8% PIN 2 = 0V PIN 3 = Control ⁴	3P aerial male inline connector. L= 715mm. PIN 1 = +24V ±8% PIN 2 = 0V PIN 3 = Control ⁴	3P aerial male inline connector. L= 715mm. PIN 1 = +24V ±8% PIN 2 = 0V PIN 3 = Control ⁴	N/A	N/A
iBlueDrive power cable (Not-included)	VCC Series	VCC Series	VCC Series	VCC Series	N/A	N/A
iBlueDrive accessories ³					N/A	N/A

Instantaneous consumption⁵ (max.)

*WT

Lighting model	DOM0906A	DOM1410A	DOM1613A	DOM2414A	DOM3218A	DOM4127A		
TYPE C 24VDC		3.8W	8.5W	7.6W	17W	29W	43W	-470C
		3.8W	8.5W	7.6W	17W	29W	43W	-525C
		3.6W	8.5W	10W	19W	33W	43W	-630C
		4W	9.2W	11W	21W	40W	51W	-850C
		3.8W	8.5W	7.6W	17W	29W	43W	-W00C
TYPE P	No 'Type P' standard LED lighting systems in this series							
TYPE S D _{max} = 1/20 Ton max= 2ms		705mA/17W	1585mA/38W	1410mA/34W	3170mA/76W	5280mA/127W	7920mA/190W	-470S
		705mA/17W	1585mA/38W	1410mA/34W	3170mA/76W	5280mA/127W	7920mA/190W	-525S
		705mA/17W	1585mA/38W	1410mA/34W	3170mA/76W	5280mA/127W	7920mA/190W	-630S
		1255mA/30W	2925mA/70W	3345mA/80W	6690mA/161W	12540mA/301W	16300mA/391W	-850S
		705mA/17W	1585mA/38W	1410mA/34W	3170mA/76W	5280mA/127W	7920mA/190W	-W00S
	900mA/22W channel	2000mA/48W channel	2000mA/48W channel	3600mA/86W channel	6000mA/144W channel	9000mA/216W channel		-RGBS
TYPE i ⁶ 		3.9W[20W/3W]	8.3W[44W/6.1W]	7.4W[39W/5.5W]	16W[48W/12W]	N/A	N/A	-470i
		6.2W[20W/4.3W]	13W[44W/9.1W]	12W[39W/8.2W]	26W[48W/18W]	N/A	N/A	-525i
		6.2W[20W/4.3W]	13W[44W/9.1W]	12W[39W/8.2W]	26W[48W/18W]	N/A	N/A	-630i
		9.1W[29W/4.8W]	21W[48W/11W]	24W[48W/12W]	24W[48W/16W]	N/A	N/A	-850i
		6.2W[20W/4.3W]	13W[44W/9.1W]	12W[39W/8.2W]	26W[48W/15W]	N/A	N/A	-W00i

N/A= Not available

(1) Environmental specifications and iconography legend in additional annex Z1.4 and Z2 respectively.
 (2) Prior to manufacturing optional modifications in standard lighting systems. Please, consult the code before ordering (additional annex Z2.1).
 (3) Accessories are not-included. More information in accessories section.

(4) iBlueDrive control input wiring specifications in additional annex Z1.2.
 (5) Bear in mind that consumption table is only to be used as a guide. To refer to real values, please, consult product label when purchasing.
 (6) Values of maximum instantaneous consumption of 'Type i' lighting systems in **Powered mode (Strobe mode / Continuous mode)**



DOM SERIES

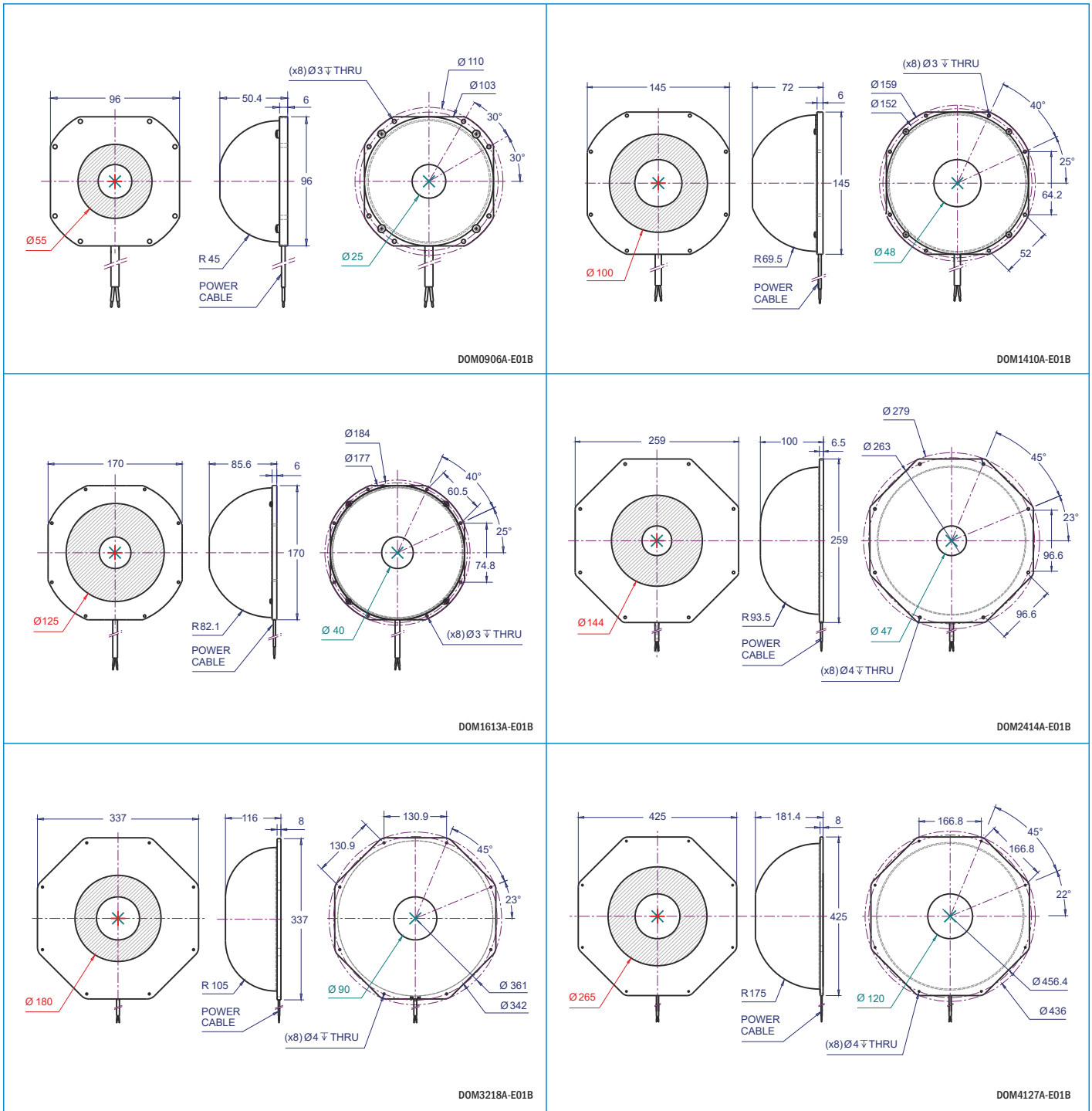

All units in millimeters, if not indicated.



Example of DOM captured image

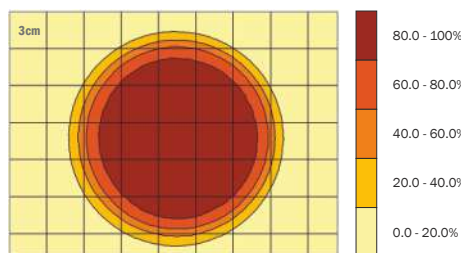

Brightness distribution of DOM1410A-630C@5mm

DOM SERIES

Dome lights (2/2) - DOM5652B to DOMB2B1A

'Cloudy day' lighting system. Illuminate objects from camera axis to all directions, providing great amount of uniform light that eliminates brightness and shadows. It is one of the most effective device in equaling the surface to illuminate.

This lighting type is ideal for shinning and curved surfaces.

Technical specifications¹

Lighting model	DOM5652B	DOM5652C	DOMB2B1A
Dimensions	570x570x264	570x570x278	1309x1309x613
Bottom Ø	516	516	1100
RWD (mm)	<50	<50	<50
Weight	2400g	2400g	17500g
IP rating	IP00	IP40	IP40
Mounting holes	(x8)Ø4.5ITHRU	(x8)Ø4.5ITHRU	(x8)Ø4.5ITHRU
Connection (Type C/S)	BN = +24V ±3% BU = 0V	N/A	BN = +24V ±3% BU = 0V
Power cable	Pre-cabled with flying leads 2x1mm ² Length=1.8m	N/A	Pre-cabled with flying leads 2x1mm ² Length=1.8m
Modifiers ²	N/A		
Accessories ³			
iBlueDrive tech.	N/A	Built-in	N/A
iBlueDrive connection	N/A	3P aerial male inline connector. L= 715mm. PIN 1 = +24V ±8% PIN 2 = 0V PIN 3 = Control ⁴	N/A
iBlueDrive power cable (Not-included)	N/A	VCC Series	N/A
iBlueDrive accessories ³	N/A		N/A

Instantaneous consumption⁵ (max.)

*WT

Lighting model	DOM5652B	DOM5652C	DOMB2B1A		
TYPE C 24VDC		N/A	N/A	N/A	-365C
		N/A	N/A	N/A	-400C
		126W	N/A	190W	-470C
		126W	N/A	190W	-525C
		126W	N/A	190W	-630C
		126W	N/A	108W	-850C
		126W	N/A	190W	-W00C
TYPE P	No 'Type P' standard LED lighting systems in this series				
TYPE S Dmax= 1/20 Ton max= 2ms		N/A	N/A	N/A	-365S
		N/A	N/A	N/A	-400S
		13860mA/333W	N/A	23750mA/570W	-470S
		13860mA/333W	N/A	23750mA/570W	-525S
		13860mA/333W	N/A	23750mA/570W	-630S
		13860mA/333W	N/A	23750mA/570W	-850S
		13860mA/333W	N/A	23750mA/570W	-W00S
TYPE i ⁷ 		N/A	154W[384W/77W]	N/A	-365i
		N/A	154W[384W/77W]	N/A	-400i
		N/A	154W[384W/77W]	N/A	-470i
		N/A	154W[384W/77W]	N/A	-525i
		N/A	154W[384W/77W]	N/A	-630i
		N/A	154W[384W/77W]	N/A	-850i
		N/A	154W[384W/77W]	N/A	-W00i

N/A= Not available

(1) Environmental specifications and iconography legend in additional annex Z1.4 and Z2 respectively.
 (2) Prior to manufacturing optional modifications in standard lighting systems. Please, consult the code before ordering (additional annex Z2.1).
 (3) Accessories are not-included. More information in accessories section.

(4) Bear in mind that consumption table is only to be used as a guide. To refer to real values, please, consult product label when purchasing.
 (5) Values of maximum instantaneous consumption of 'Type i' lighting systems in Powered mode [Strobe mode / Continuous mode]



DOM SERIES

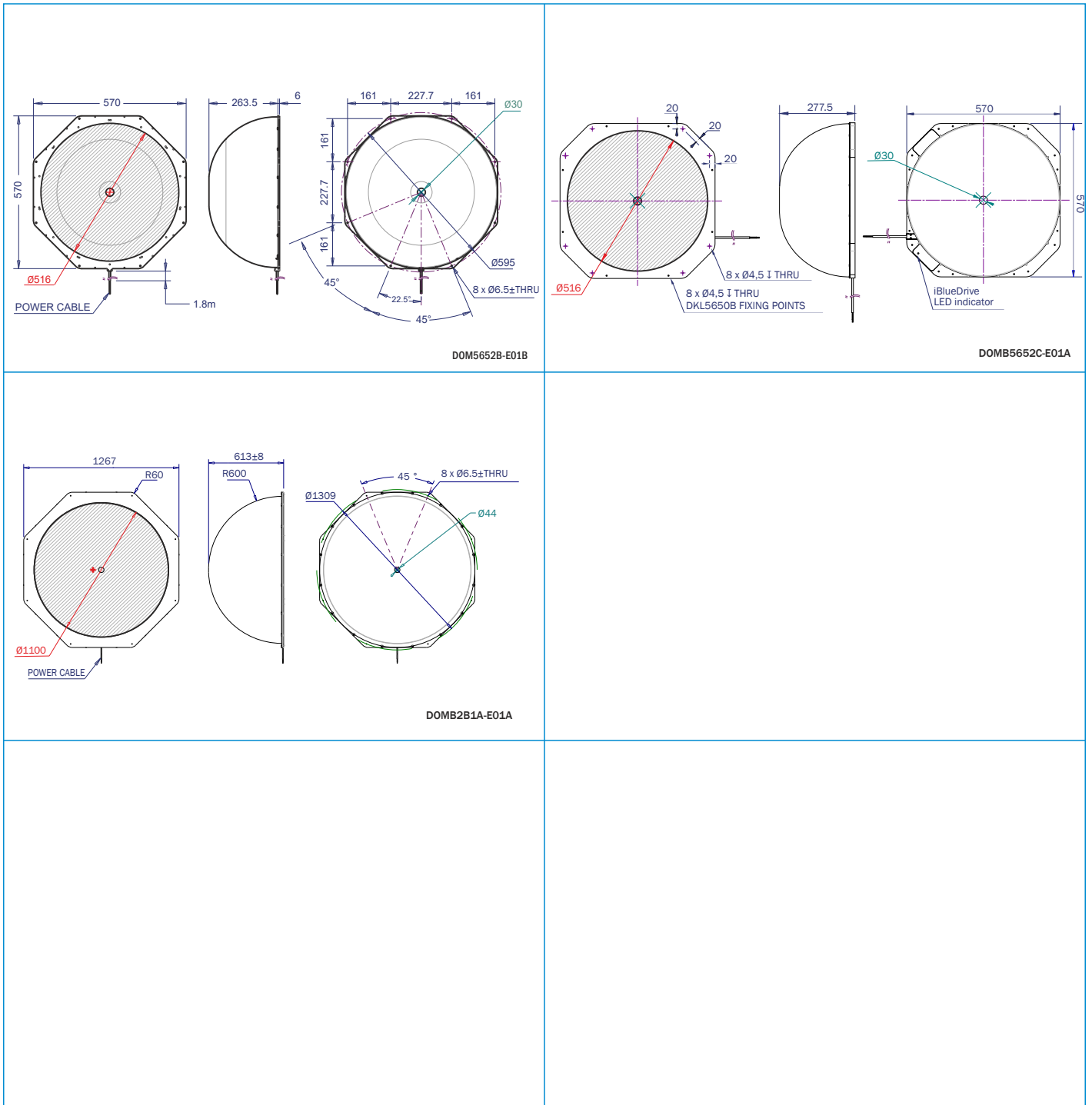

All units in millimeters, if not indicated.



Example of DOM captured image

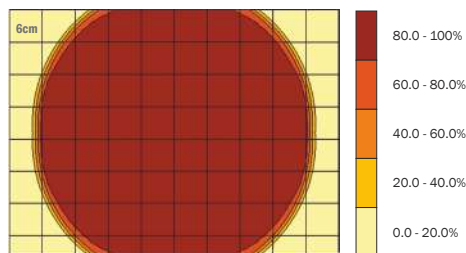



Brightness distribution of DOM5652B-W00C@5mm

DTL SERIES











Transmitted dome lights

Differently from DOM series, the light is transmitted uniformly through the dome, which is of translucent material, allowing more compact domes better covering the object. Specially designed for bright curved surfaces, eliminating brightness and shadows. Also, this system can get the lighting dome divided in three sectors controllable independently, increasing versatility. Ideal for inspection of welds.

► Technical specifications¹

Lighting model	DTL3521B
	
Dimensions	Ø225x85
Bottom	55
RWD (mm)	<50
Weight	1440g
IP rating	IP40
Mounting holes	(x2)M8I8 (x6)M4I6
Connection (Type C/S)	4P male chassis connector PIN 1 = +24V ±3% PIN 2 = 0V inner sector PIN 3 = 0V middle sector PIN 4 = 0V outer sector
Power cable (Not-included)	VCD Series
Modifiers²	N/A
Accessories³	
iBlueDrive tech.	N/A

► Instantaneous consumption⁴ (max.)

Lighting model		DTL3521B (inner)	DTL3521B (middle)	DTL3521B (outer)	*WT
TYPE C 24VDC		6.4W	13W	16W	-470C
		6.4W	13W	16W	-525C
		6.4W	13W	16W	-630C
		6.4W	13W	16W	-850C
		6.4W	13W	16W	-W00C
TYPE P		No "Type P" standard LED lighting systems in this series			
TYPE S D _{max} = 1/20 Ton max = 2ms		1055mA/25W	2110mA/51W	2640mA/63W	-470S
		1055mA/25W	2110mA/51W	2640mA/63W	-525S
		1055mA/25W	2110mA/51W	2640mA/63W	-630S
		2510mA/60W	5015mA/120W	6270mA/150W	-850S
		1055mA/25W	2110mA/51W	2640mA/63W	-W00S
	1200mA/29W channel	2100mA/50W channel	3000mA/72W channel	-RGBS	
TYPE i		No "Type i" standard LED lighting systems in this series			

(1) Environmental specifications and iconography legend in additional annex Z1.4 and Z2 respectively.

(2) Prior to manufacturing optional modifications in standard lighting systems. Please, consult the code before ordering (additional annex Z2.1).

(3) Accessories are not-included. More information in accessories section.

(4) Bear in mind that consumption table is only to be used as a guide. To refer to real values, please, consult product label when purchasing.



DTL SERIES

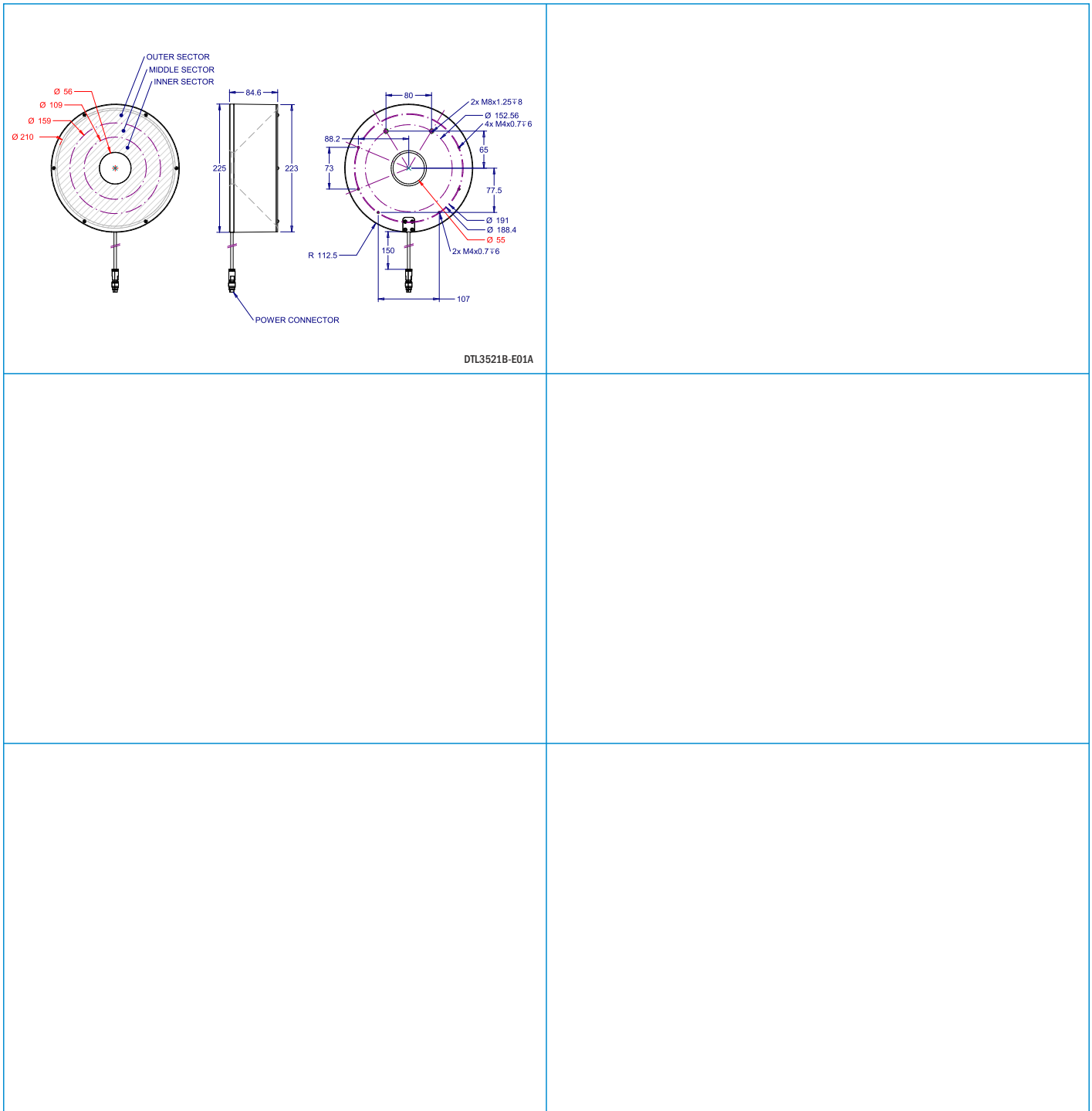

All units in millimeters, if not indicated.

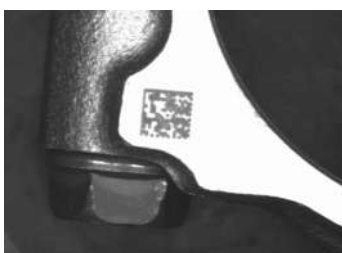

Example of DTL captured image

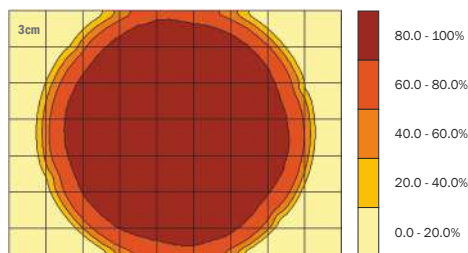

Brightness distribution of DTL3521B-630C@5mm

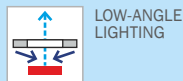

PLA SERIES

High-powered linear lights projectors

Linear projectors with high-powered LEDs. Designed with iBlueDrive technology for illuminating big areas with compact lighting systems due to its angle of emission. Thanks to their small size and light weight, they are ideal for operating with robots. These lighting systems provide great contrast and highlight textures, reliefs and fissures of illuminated object. Available with various angles of emission.

► Technical specifications¹

Lighting model	PLA0513A	PLA1013A	PLA1026A	PLA2026A
Dimensions	130x40x16	130x40x16	260x40x16	260x40x16
RWD (mm)	>50	>50	>50	>50
Weight	141g	145g	267g	271g
IP rating	IP40	IP40	IP40	IP40
Mounting holes	(x4)M2I5	(x4)M2I5	(x6)M2I5	(x6)M2I5
Connection (Type C)	3P aerial male connector. L=150mm PIN 1= +24V ±8% PIN 2= 0V PIN 3= Control	N/A	3P aerial male connector. L=150mm PIN 1= +24V ±8% PIN 2= 0V PIN 3= Control	N/A
Modifiers ²				
Accessories ³				
Power cable (Not-included)	VCC Series	N/A	VCC Series	N/A
iBlueDrive tech.	N/A	Built-in	N/A	Built-in
iBlueDrive connection	N/A	3P aerial male connector. L= 150mm PIN 1 = +24V ±8% PIN 2 = 0V PIN 3 = Control ⁴	N/A	3P aerial male connector. L= 150mm PIN 1 = +24V ±8% PIN 2 = 0V PIN 3 = Control ⁴
iBlueDrive power cable (Not-included)	N/A	VCC Series	N/A	VCC Series
iBlueDrive accessories ³	N/A		N/A	

► Instantaneous consumption⁵ (max.)

*WT

Lighting model	PLA0513A	PLA1013A	PLA1026A	PLA2026A		
TYPE C 24VDC		5.5W	N/A	11W	N/A	-470C
		5.5W	N/A	11W	N/A	-525C
		5.5W	N/A	11W	N/A	-630C
		5W	N/A	11W	N/A	-850C
		5.5W	N/A	11W	N/A	-W00C
TYPE P	No "Type P" standard LED lighting systems in this series					
TYPE S	No "Type S" standard LED lighting systems in this series					
iBlue Drive i6		N/A	24W [48W/12W]	N/A	48W [96W/24W]	-470i
		N/A	24W [48W/12W]	N/A	48W [96W/24W]	-525i
		N/A	19W [34W/12W]	N/A	37W [68W/24W]	-630i
		N/A	12W [24W/6.5W]	N/A	24W [48W/12W]	-850i
		N/A	24W [48W/12W]	N/A	48W [96W/24W]	-W00i

N/A= Not available

(1) Environmental specifications and iconography legend in additional annex Z1.4 and Z2 respectively.
 (2) Angles of emission of PLA series projectors. If not indicated, default angle will be /AM. Please, consult the code to select a different angle of emission before ordering (additional annex Z2.1).

(3) Accessories are not-included. More information in accessories section.
 (4) iBlueDrive control input wiring specifications in additional annex Z1.2.
 (5) Bear in mind that consumption table is only to be used as a guide. To refer to real values, please, consult product label when purchasing.
 (6) Values of maximum instantaneous consumption of "Type I" lighting systems in Powered mode [Strobe mode / Continuous mode]



PLA SERIES

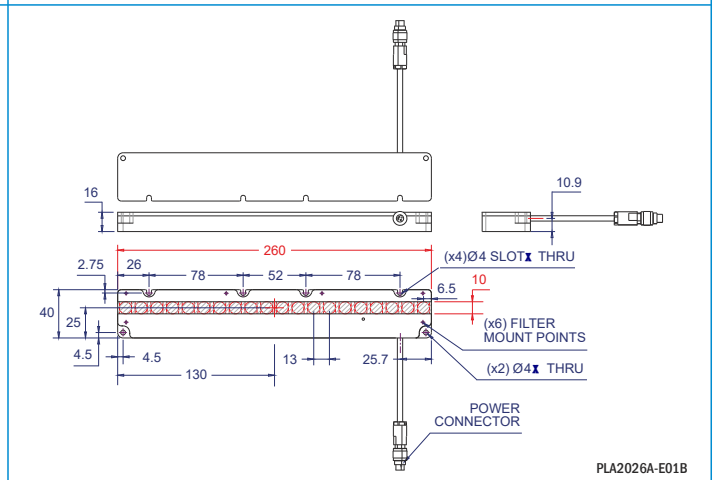
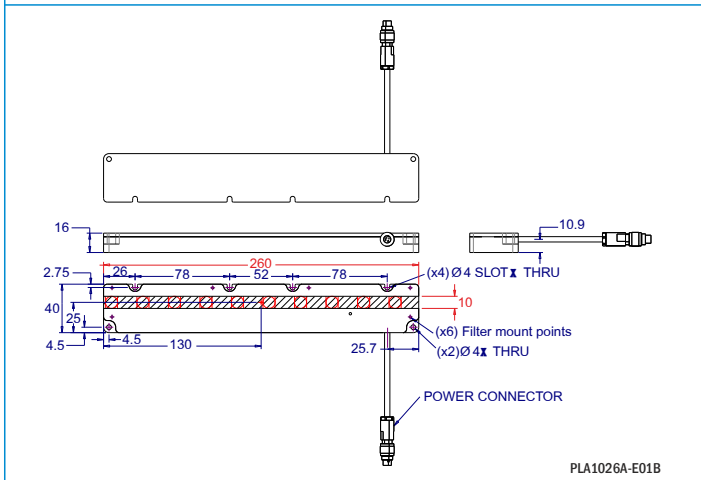
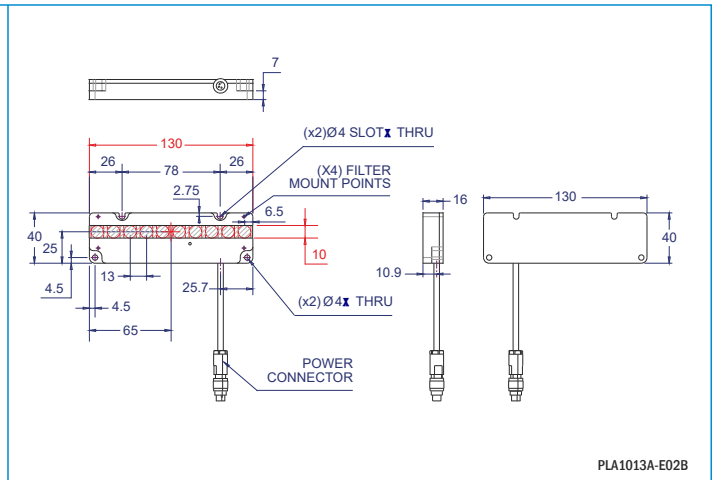
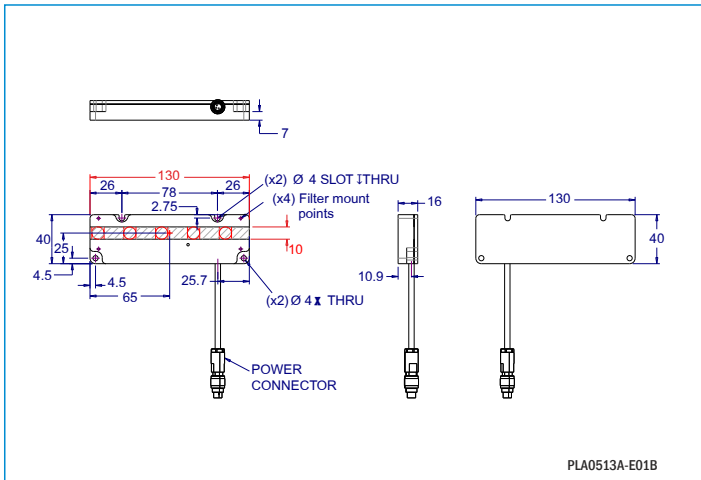

All units in millimeters, if not indicated.



Example of PLA captured image

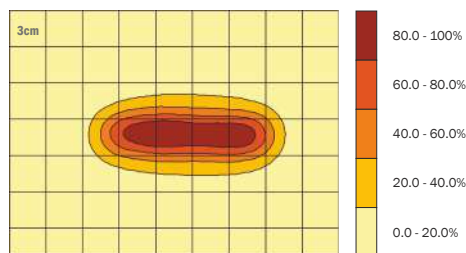

Brightness distribution of PLA1013A-630i/AN@100mm

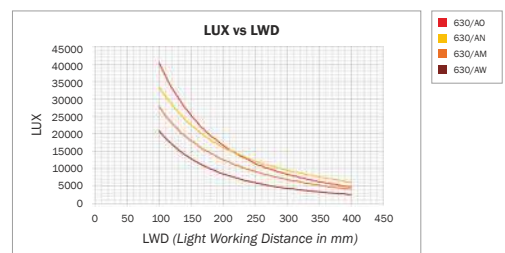

PLA1013A-630i light intensity.

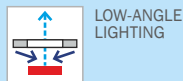

PLC SERIES

Compact linear lights projectors (1/2)

Linear projector with high illumination for larger areas, longer distances and better performances.

This system produces great contrast and emphasizes textures, relieves and fissures that the lighted object could have.

► Technical specifications¹

Lighting model	PLC0307A	PLC0615A	PLC1231A
Dimensions	87x40x48	165x40x48	321x40x48
LEDs number	3	6	12
RWD (mm)	>50	>50	>50
Weight	220g	400g	775g
IP rating	IP40	IP40	IP40
Mounting holes	(x2)M4I6	(x2)M4I6	(x2)M4I6
Connection (Type C)	3P male chassis connector PIN 1 = +24V ±8% PIN 2 = 0V PIN 3 = Control ²	3P male chassis connector PIN 1 = +24V ±8% PIN 2 = 0V PIN 3 = Control ²	3P male chassis connector PIN 1 = +24V ±8% PIN 2 = 0V PIN 3 = Control ²
Power cable (Not-included)	VCC Series	VCC Series	VCC Series
Modifiers³	N/A	N/A	N/A
Accessories⁴			
iBlueDrive tech.	NO	NO	NO
iBlueDrive connection	NO	NO	NO
iBlueDrive power cable (Not-included)	NO	NO	NO
iBlueDrive accessories³	NO	NO	NO

► Instantaneous consumption⁵ (max.)

Lighting model	PLC0307A	PLC0615A	PLC1231A	*WT	
TYPE C 24VDC		N/A	N/A	N/A	-365C
		5W	10W	20W	-400C
		5W	10W	20W	-470C
		5W	10W	20W	-525C
		5W	9W	18W	-630C
		5W	9W	18W	-850C
		5W	10W	20W	-W00C
TYPE P	No 'Type P' standard LED lighting systems in this series				
TYPE S	No 'Type S' standard LED lighting systems in this series				
TYPE i	No 'Type i' standard LED lighting systems in this series				

N/A= Not available

(1) Environmental specifications and iconography legend in additional annex Z1.4 and Z2 respectively.

(2) Control input specifications of PLC series in additional annex Z1.1.

(3) Prior to manufacturing optional modifications in standard lighting systems. Please, consult the code before ordering (additional annex Z2.1).

(4) Accessories are not-included. More information in accessories section.

(5) Bear in mind that consumption table is only to be used as a guide. To refer to real values, please, consult product label when purchasing.



PLC SERIES

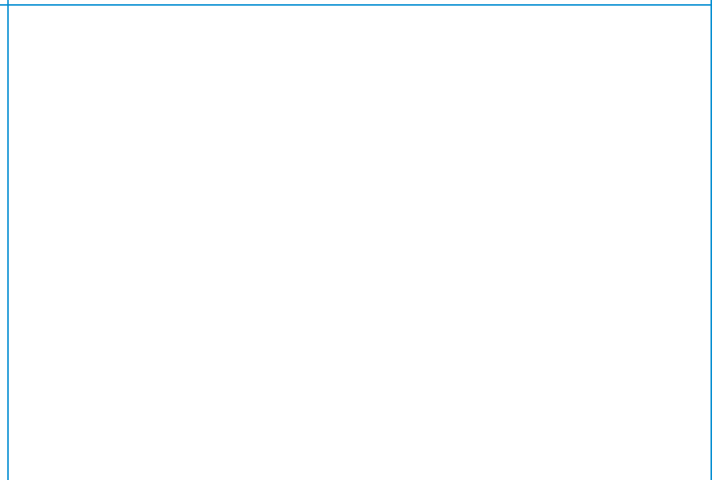
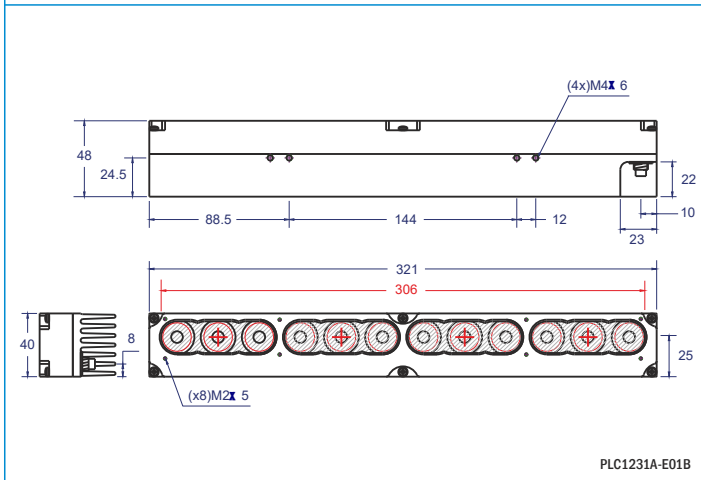
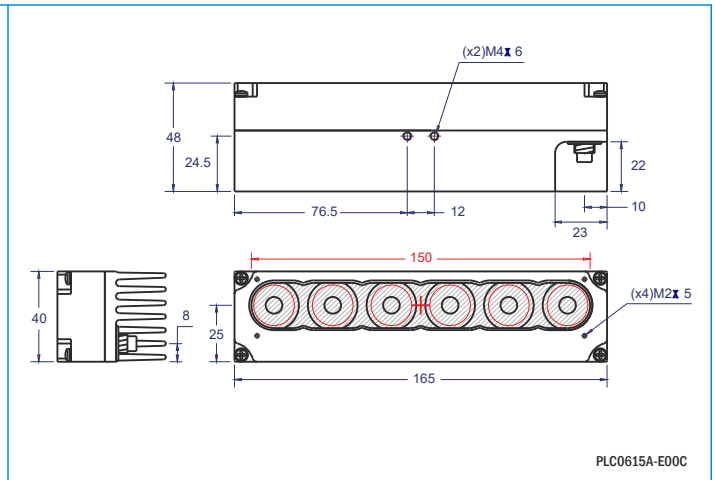
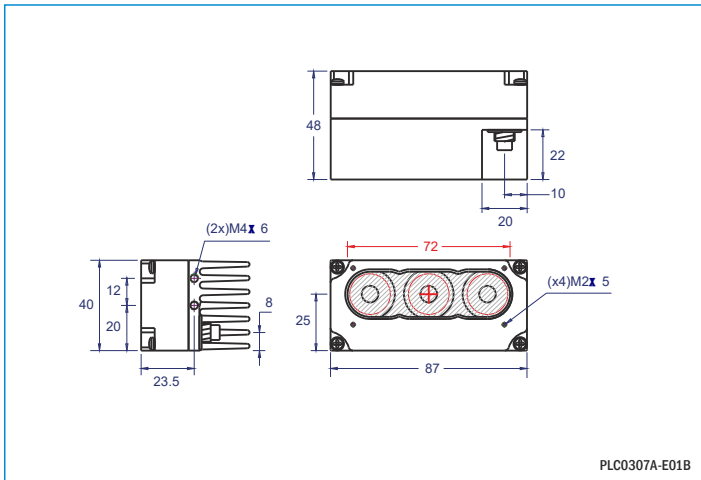

All units in millimeters, if not indicated.



Example of PLC captured image

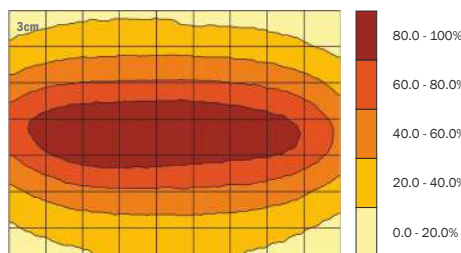

Brightness distribution of PLC1231A-630C@350mm

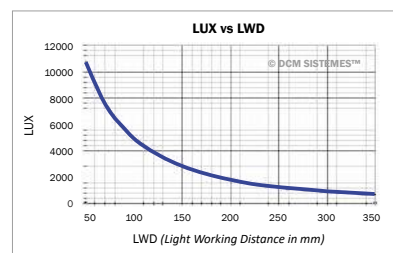

PLC1231A-630C light intensity.

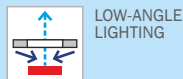

PLC SERIES

Compact linear lights projectors (2/2)

Linear projector with high illumination for larger areas, longer distances and better performances.

This system produces great contrast and emphasizes textures, relieves and fissures that the lighted object could have.

► Technical specifications¹

Lighting model	PLC0412C	PLC0824C	PLC1236C	PLC1648C	PLC2060C
Dimensions	120x39x34.5	240x39x34.5	360x37x33	480x39x34.5	600x39x34.5
LEDs number	4	8	12	16	20
RWD (mm)	>50	>50	>50	>50	>50
Weight	264g	510g	680g	1070g	1335g
IP rating	IP65	IP65	IP65	IP65	IP65
Mounting holes	(x2)M4I6	(x2)M4I6	(x4)M4I6	(x2)M4I6	(x2)M4I6
Connection (Type C)	3P aerial male connector PIN 1 = +24V ±8% PIN 2 = 0V PIN 3 = Control ²	3P aerial male connector PIN 1 = +24V ±8% PIN 2 = 0V PIN 3 = Control ²	3P aerial male connector PIN 1 = +24V ±8% PIN 2 = 0V PIN 3 = Control ²	3P aerial male connector PIN 1 = +24V ±8% PIN 2 = 0V PIN 3 = Control ²	3P aerial male connector PIN 1 = +24V ±8% PIN 2 = 0V PIN 3 = Control ²
Power cable (Not-included)	VCC Series	VCC Series	VCC Series	VCC Series	VCC Series
Modifiers³					
Accessories⁴					
iBlueDrive tech.	Built-in	Built-in	Built-in	Built-in	Built-in
iBlueDrive connection	3P aerial male connector. L= 150mm PIN 1 = +24V ±8% PIN 2 = 0V PIN 3 = Control ⁵	3P aerial male connector. L= 150mm PIN 1 = +24V ±8% PIN 2 = 0V PIN 3 = Control ⁵	3P aerial male connector. L= 150mm PIN 1 = +24V ±8% PIN 2 = 0V PIN 3 = Control ⁵	3P aerial male connector. L= 150mm PIN 1 = +24V ±8% PIN 2 = 0V PIN 3 = Control ⁵	3P aerial male connector. L= 150mm PIN 1 = +24V ±8% PIN 2 = 0V PIN 3 = Control ⁵
iBlueDrive power cable (Not-included)	VCC Series	VCC Series	VCC Series	VCC Series	VCC Series
iBlueDrive accessories³					

► Instantaneous consumption⁶ (max.)

*WT

Lighting model	PLC0412C	PLC0824C	PLC1236C	PLC1648C	PLC2060C	
TYPE C 24VDC	5,4W	10,8W	16,2W	21,6W	27W	-365C
	5W	10W	18W	24W	24W	-400C
	5W	10W	18W	24W	24W	-470C
	5W	10W	18W	24W	24W	-525C
	4.5W	9.5W	15W	20W	20W	-630C
	4.5W	9.5W	14,5W	19W	24W	-850C
	4.5W	9.5W	18W	20W	20W	-W00C
TYPE P	No "Type P" standard LED lighting systems in this series					
TYPE S	No "Type S" standard LED lighting systems in this series					
TYPE i 	12W [24W/6.5W]	24W [48W/12W]	36W [72W/18W]	48W [96W/24W]	60W [120W/30W]	-365i
	12W [24W/6.5W]	24W [48W/12W]	36W [72W/18W]	48W [96W/24W]	60W [120W/30W]	-400i
	12W [24W/6.5W]	24W [48W/12W]	36W [72W/18W]	48W [96W/24W]	60W [120W/30W]	-470i
	12W [24W/6.5W]	24W [48W/12W]	36W [72W/18W]	48W [96W/24W]	60W [120W/30W]	-525i
	12W [24W/6.5W]	24W [48W/12W]	36W [72W/18W]	48W [96W/24W]	60W [120W/30W]	-630i
	12W [24W/6.5W]	12W [24W/6.5W]	24W [48W/12W]	24W [48W/12W]	36W [72W/18W]	-850i
	12W [24W/6.5W]	24W [48W/12W]	36W [72W/18W]	48W [96W/24W]	60W [120W/30W]	-W00i

(1) Environmental specifications and iconography legend in additional annex Z1.4 and Z2 respectively.

(2) Control input specifications of PLC series in additional annex Z1.1.

(3) Prior to manufacturing optional modifications in standard lighting systems. Please, consult the code before ordering (additional annex Z2.1).

(4) Accessories are not-included. More information in accessories section.

(5) iBlueDrive control input wiring specifications in additional annex Z1.2.

(6) Bear in mind that consumption table is only to be used as a guide. To refer to real values, please, consult product label when purchasing.



PLC SERIES

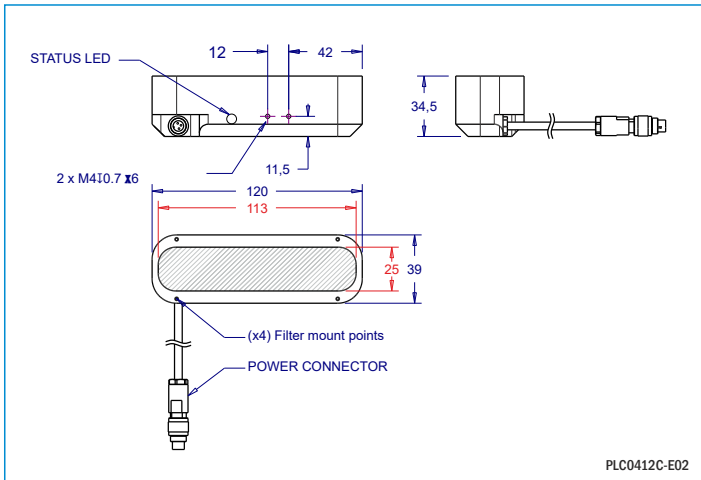

PLC0412C-E02

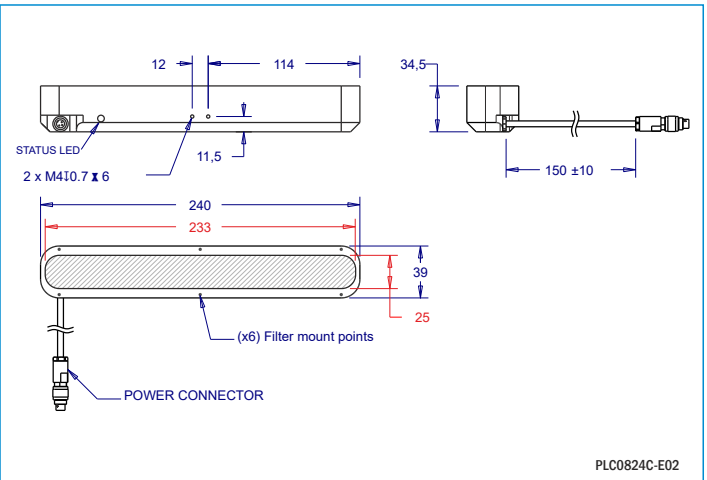

PLC0824C-E02

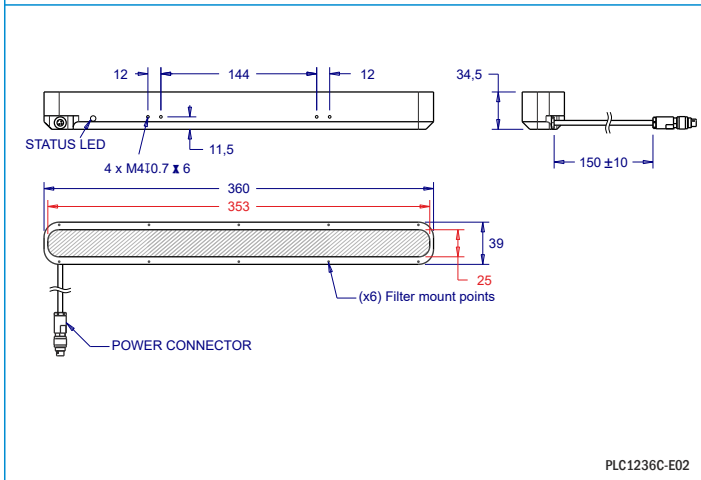

PLC1236C-E02

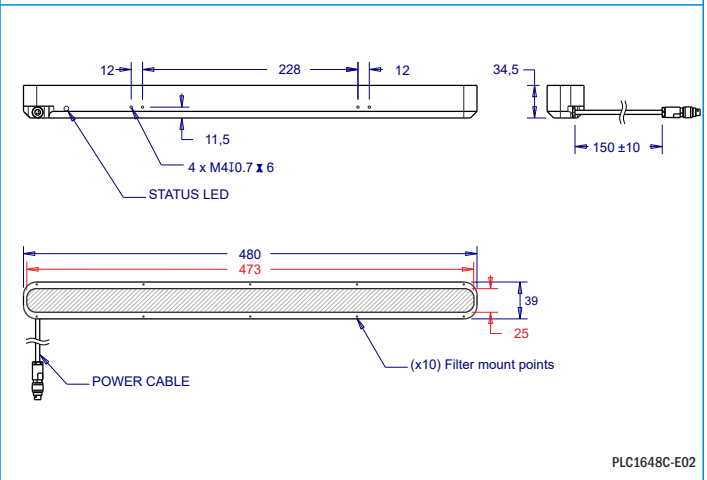

PLC1648C-E02

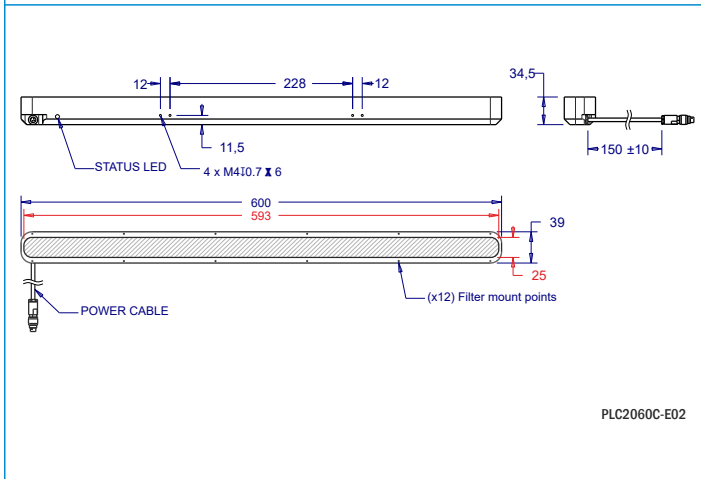

PLC2060C-E02

All units in millimeters, if not indicated.



Example of PLC captured image

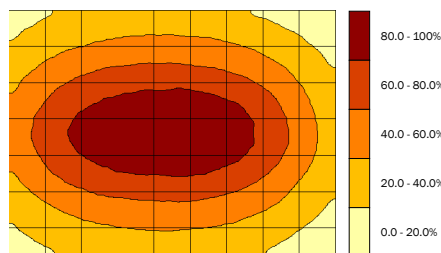

Brightness distribution of PLC0824C-630C/AW@100mm

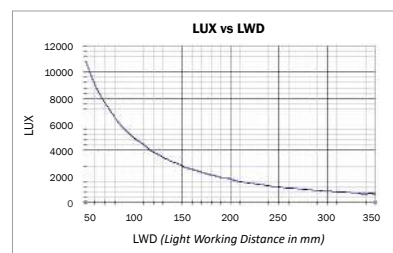

PLC0824C-630C light intensity.

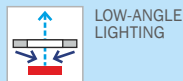

PLD SERIES

Direct linear lights projectors

Leds bar projector that produces a great contrast and emphasizes textures, relieves and fissures of the inspected object. It operates punctually lighting because any relief, even the smallest one, produces a shadow.

Technical specifications¹

Lighting model	PLD0602B	PLD1002A	PLD1302B	PLD1802A	PLD2602A
Dimensions	86x20x24	122x20x24	150x20x24	201x20x24	280x20x24
Active surface	64x16	100x16	128x16	180x16	259x16
RWD (mm)	>50	>50	>50	>50	>50
Weight	80g	98g	125g	150g	205g
IP rating	IP40 ²	IP40 ²	IP40 ²	IP40 ²	IP40 ²
Mounting holes	(x3)(x2)M4I6	(x3)(x2)M4I6	(x3)(x2)M4I6	(x3)(x2)M4I6	(x3)(x2)M4I6
Connection (Type C/P/S)	2P male chassis connector PIN 1 = +24V ±3% PIN 2 = 0V	2P male chassis connector PIN 1 = +24V ±3% PIN 2 = 0V	2P male chassis connector PIN 1 = +24V ±3% PIN 2 = 0V	2P male chassis connector PIN 1 = +24V ±3% PIN 2 = 0V	2P male chassis connector PIN 1 = +24V ±3% PIN 2 = 0V
Power cable (Not-included)	VCB Series	VCB Series	VCB Series	VCB Series	VCB Series
Modifiers ³	N/A	N/A	N/A	N/A	N/A
Accessories ⁴					
iBlueDrive tech.	inline	inline	inline	inline	inline
iBlueDrive connection	3P aerial male inline connector. L= 715mm. PIN 1 = +24V ±8% PIN 2 = 0V PIN 3 = Control ⁵	3P aerial male inline connector. L= 715mm. PIN 1 = +24V ±8% PIN 2 = 0V PIN 3 = Control ⁵	3P aerial male inline connector. L= 715mm. PIN 1 = +24V ±8% PIN 2 = 0V PIN 3 = Control ⁵	3P aerial male inline connector. L= 715mm. PIN 1 = +24V ±8% PIN 2 = 0V PIN 3 = Control ⁵	3P aerial male inline connector. L= 715mm. PIN 1 = +24V ±8% PIN 2 = 0V PIN 3 = Control ⁵
iBlueDrive power cable (Not-included)	VCC Series	VCC Series	VCC Series	VCC Series	VCC Series
iBlueDrive accessories ⁴					

Instantaneous consumption⁶ (max.)

*WT

Lighting model	PLD0602B	PLD1002A	PLD1302B	PLD1802A	PLD2602A		
TYPE C 24VDC		1.3W	2.5W	3W	4.2W	5W	-470C
		0.6W	1.3W	1.4W	2.2W	2.5W	-525C
		1.8W	3.5W	2.9W	5.8W	7W	-630C
		2.2W	2.2W	3.6W	3.6W	4.3W	-850C
TYPE P D _{max} = 1/2 Ton max= 60s		1.6W	3.1W	3.7W	5.3W	6.4W	-365P
		1.6W	3.1W	3.7W	5.3W	6.4W	-400P
		1.6W	3.1W	3.7W	5.3W	6.4W	-W00P
TYPE S D _{max} = 1/20 Ton max= 2ms		265mA/6.4W	530mA/13W	615mA/15W	880mA/21W	1055mA/25W	-365S
		265mA/6.4W	530mA/13W	615mA/15W	880mA/21W	1055mA/25W	-400S
		265mA/6.4W	530mA/13W	615mA/15W	880mA/21W	1055mA/25W	-470S
		165mA/4W	330mA/7.9W	385mA/9.2W	550mA/13W	660mA/16W	-525S
		265mA/6.4W	530mA/13W	615mA/15W	880mA/21W	1055mA/25W	-630S
		625mA/15W	625mA/15W	1045mA/25W	1045mA/25W	1255mA/30W	-850S
		265mA/6.4W	530mA/13W	615mA/15W	880mA/21W	1055mA/25W	-W00S
		CUS	CUS	CUS	400mA/10W channel	CUS	-RGBS
TYPE I ⁷ 		1.3W[7.7W/1.1W]	2.2W[15W/1.6W]	3.2W[17W/2.5W]	3.4W[24W/2.4W]	3.9W[29W/2.8W]	-365i
		1.9W[7.7W/1.2W]	3.4W[15W/1.9W]	3.8W[17W/2.2W]	5.3W[24W/2.9W]	6.2W[29W/3.4W]	-400i
		1.8W[7.7W/1.3W]	3.1W[15W/2.2W]	3.5W[17W/2.5W]	4.8W[24W/3.4W]	5.7W[29W/3.9W]	-470i
		1.5W[4.1W/1.1W]	2.6W[7.7W/1.6W]	3W[8.9W/1.8W]	4.1W[12W/2.4W]	4.8W[15W/2.8W]	-525i
		2.6W[7.7W/1.9W]	4.8W[15W/3.4W]	5.5W[17W/3.8W]	7.7W[24W/5.3W]	9.1W[29W/6.2W]	-630i
		4.4W[15W/2.6W]	4.4W[15W/2.6W]	7.1W[24W/4.1W]	7.1W[24W/4.1W]	8.4W[29W/4.8W]	-850i
		1.9W[7.7W/1.2W]	3.4W[15W/1.9W]	3.8W[17W/2.2W]	5.3W[24W/2.9W]	6.2W[29W/3.4W]	-W00i

CUS = Custom

(1) Environmental specifications and iconography legend in additional annex Z1.4 and Z2 respectively.
 (2) IP43 if the system is positioned so that the light falls vertically.
 (3) Prior to manufacturing optional modifications in standard lighting systems. Please, consult the code before ordering (additional annex Z2.1).

(4) Accessories are not-included. More information in accessories section.
 (5) iBlueDrive control input wiring specifications in additional annex Z1.2.
 (6) Bear in mind that consumption table is only to be used as a guide. To refer to real values, please, consult product label when purchasing.
 (7) Values of maximum instantaneous consumption of 'Type I' lighting systems in Powered mode [Strobe mode / Continuous mode]



PLD SERIES

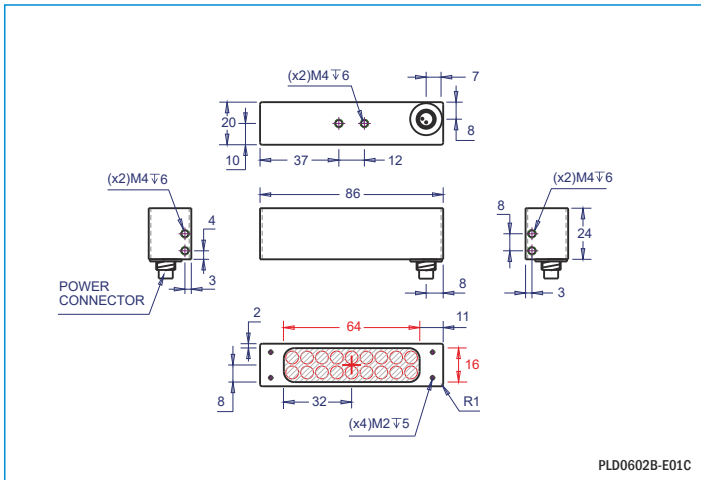

PLD0602B-E01C

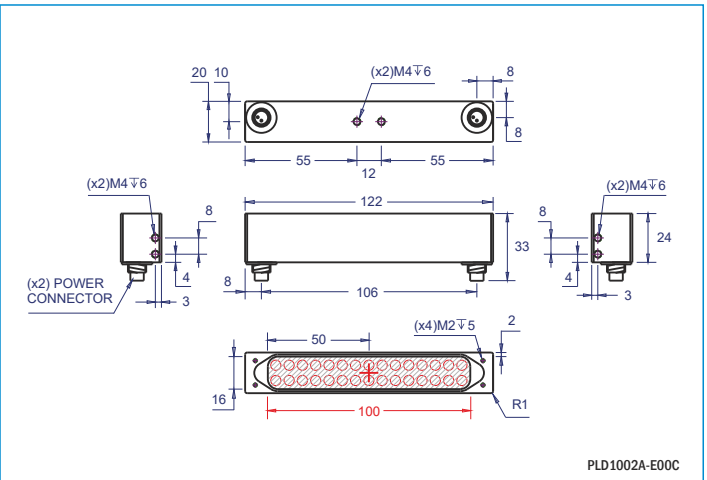

PLD1002A-E00C

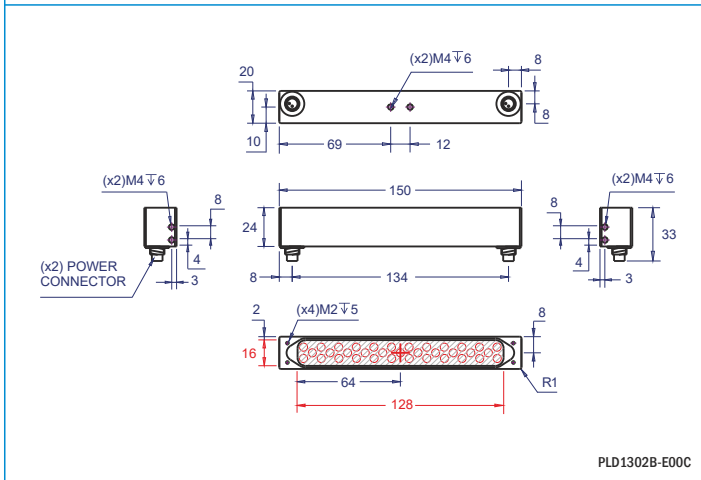

PLD1302B-E00C

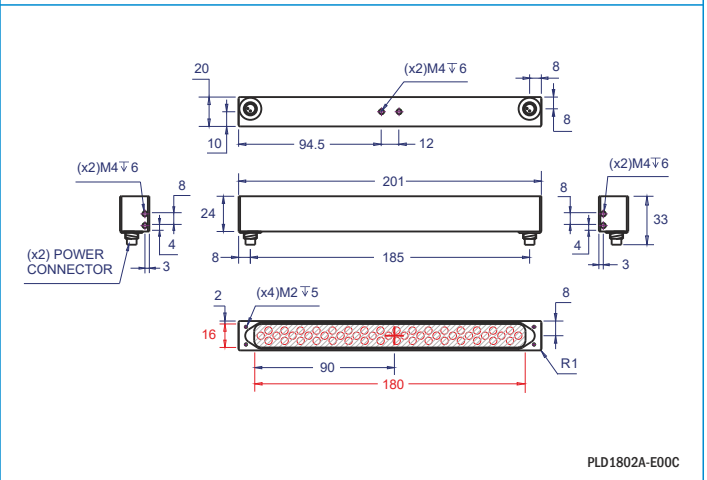

PLD1802A-E00C

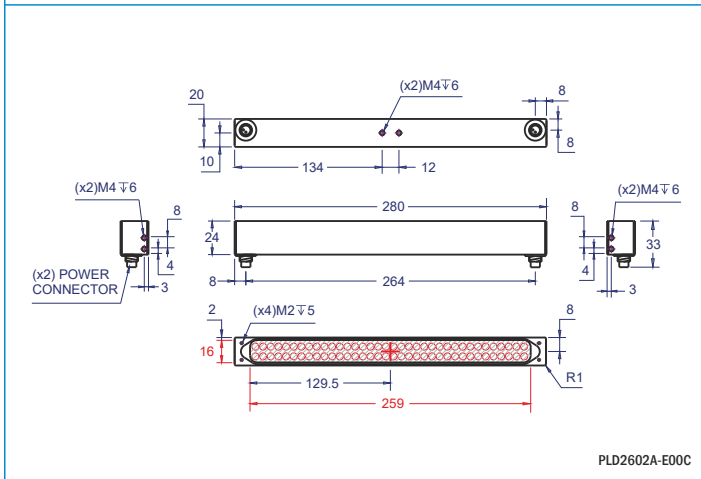

PLD2602A-E00C

All units in millimeters, if not indicated.

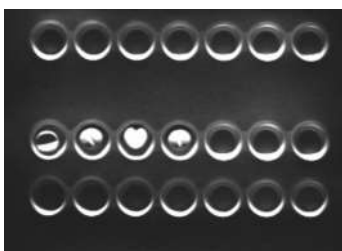

Example of PLD captured image

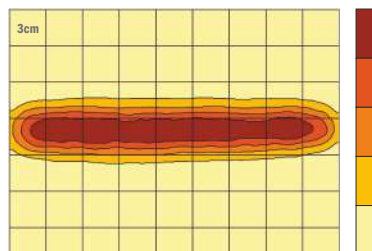

Brightness distribution of PLD2602A-630C@50mm

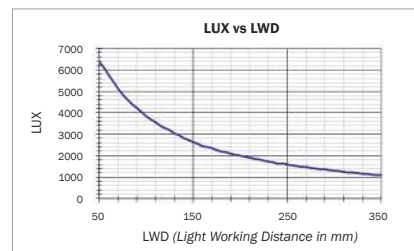

PLD2602A-630C light intensity.

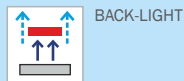
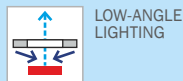

PLU SERIES

Diffuse linear lights projectors

LED's diffuse bar projector which provides a great amount of uniform light. This system uses high intensity LEDs in order to illuminate diffusely small surfaces.

► Technical specifications¹

Lighting model	PLU0602B	PLU1002A	PLU1302B	PLU1802A	PLU2602A
Dimensions	86x20x24	122x20x24	150x20x24	201x20x24	280x20x24
Active surface	64x16	100x16	128x16	180x16	259x16
RWD (mm)	>100	>110	>125	>160	>200
Weight	80g	98g	125g	150g	205g
IP rating	IP40 ²	IP40 ²	IP40 ²	IP40 ²	IP40 ²
Mounting holes	(x3)(x2)M4I6	(x3)(x2)M4I6	(x3)(x2)M4I6	(x3)(x2)M4I6	(x3)(x2)M4I6
Connection (Type C/S)	2P male chassis connector PIN 1 = +24V ±3% PIN 2 = 0V	2P male chassis connector PIN 1 = +24V ±3% PIN 2 = 0V	2P male chassis connector PIN 1 = +24V ±3% PIN 2 = 0V	2P male chassis connector PIN 1 = +24V ±3% PIN 2 = 0V	2P male chassis connector PIN 1 = +24V ±3% PIN 2 = 0V
Power cable (Not-included)	VCB Series	VCB Series	VCB Series	VCB Series	VCB Series
Modifiers ³	N/A	N/A	N/A	N/A	N/A
Accessories ⁴					
iBlueDrive tech.	inline	inline	inline	inline	inline
iBlueDrive connection	3P aerial male inline connector. L= 715mm. PIN 1 = +24V ±8% PIN 2 = 0V PIN 3 = Control ⁵	3P aerial male inline connector. L= 715mm. PIN 1 = +24V ±8% PIN 2 = 0V PIN 3 = Control ⁵	3P aerial male inline connector. L= 715mm. PIN 1 = +24V ±8% PIN 2 = 0V PIN 3 = Control ⁵	3P aerial male inline connector. L= 715mm. PIN 1 = +24V ±8% PIN 2 = 0V PIN 3 = Control ⁵	3P aerial male inline connector. L= 715mm. PIN 1 = +24V ±8% PIN 2 = 0V PIN 3 = Control ⁵
iBlueDrive power cable (Not-included)	VCC Series	VCC Series	VCC Series	VCC Series	VCC Series
iBlueDrive accessories ⁴					

► Instantaneous consumption⁶ (max.)

Lighting model	PLU0602B	PLU1002A	PLU1302B	PLU1802A	PLU2602A	*WT	
TYPE C 24VDC		1.7W	2.8W	3.8W	5.5W	6.6W	-470C
		1.7W	2.8W	3.8W	5.5W	6.6W	-525C
		1.8W	2.9W	4.1W	4.1W	7W	-630C
		1.8W	N/A	4.1W	4.1W	4.4W	-850C
		1.7W	2.8W	3.8W	3.8W	6.6W	-W00C
TYPE P	No "Type P" standard LED lighting systems in this series						
TYPE S D _{max} = 1/20 Ton max= 2ms		265mA/6.4W	440mA/11W	615mA/15W	880mA/21W	1055mA/25W	-470S
		265mA/6.4W	440mA/11W	615mA/15W	880mA/21W	1055mA/25W	-525S
		265mA/6.4W	440mA/11W	615mA/15W	615mA/15W	1055mA/25W	-630S
		625mA/15W	1045mA/25W	1465mA/35W	1465mA/35W	2510mA/60W	-850S
		265mA/6.4W	375mA/9W	615mA/15W	615mA/15W	1055mA/25W	-W00S
TYPE i ⁷ 		CUS	CUS	900mA/22W channel	900mA/22W channel	CUS	-RGS
		1.8W[7.7W/1.4W]	2.6W[12W/2W]	3.5W[17W/2.6W]	4.8W[24W/3.6W]	5.7W[29W/4.2W]	-470i
		2.6W[7.7W/1.9W]	4.1W[12W/2.9W]	5.5W[17W/3.8W]	7.7W[24W/5.3W]	9.1W[29W/6.2W]	-525i
		2.6W[7.7W/1.9W]	4.1W[12W/2.9W]	5.5W[17W/3.8W]	5.5W[17W/3.8W]	9.1W[29W/6.2W]	-630i
		4.8W[15W/2.6W]	7.7W[24W/4.1W]	11W[34W/5.5W]	11W[34W/5.5W]	9.1W[29W/4.8W]	-850i
	2.6W[7.7W/1.9W]	4.1W[12W/2.9W]	5.5W[17W/3.8W]	5.5W[17W/3.8W]	9.1W[29W/6.2W]	-W00i	

N/A= Not available CUS = Custom

(1) Environmental specifications and iconography legend in additional annex Z1.4 and Z2 respectively.

(2) IP43 if the system is positioned so that the light falls vertically.

(3) Prior to manufacturing optional modifications in standard lighting systems. Please, consult the code before ordering (additional annex Z2.1).

(4) Accessories are not-included. More information in accessories section.

(5) iBlueDrive control input wiring specifications in additional annex Z1.2.

(6) Bear in mind that consumption table is only to be used as a guide. To refer to real values, please, consult product label when purchasing.

(7) Values of maximum instantaneous consumption of "Type i" lighting systems in Powered mode [Strobe mode / Continuous mode]



PLU SERIES

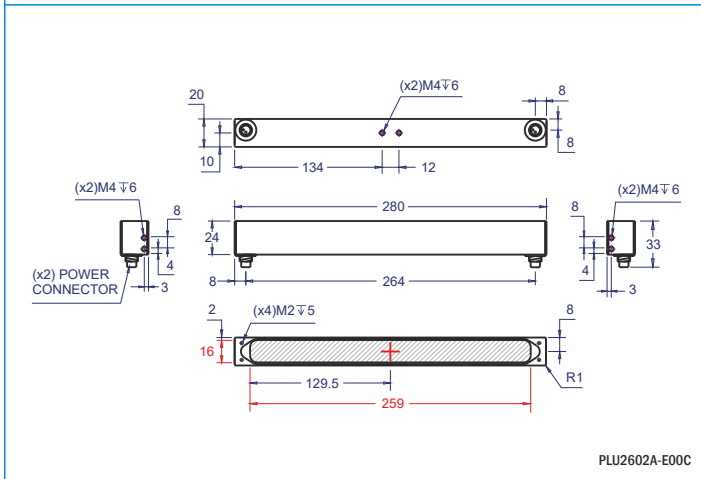
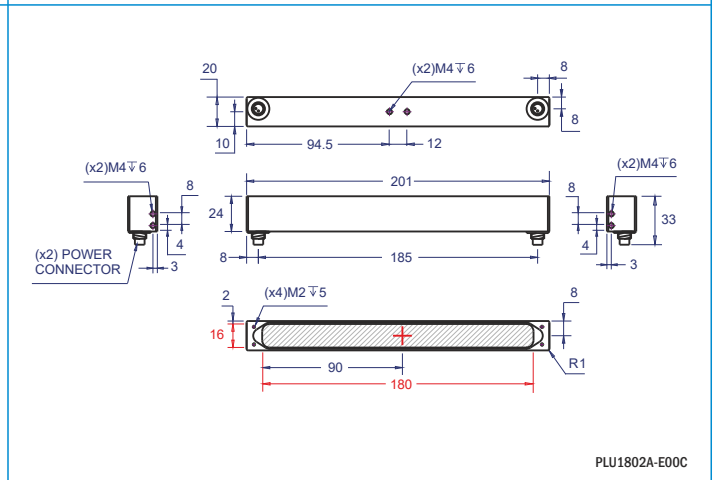
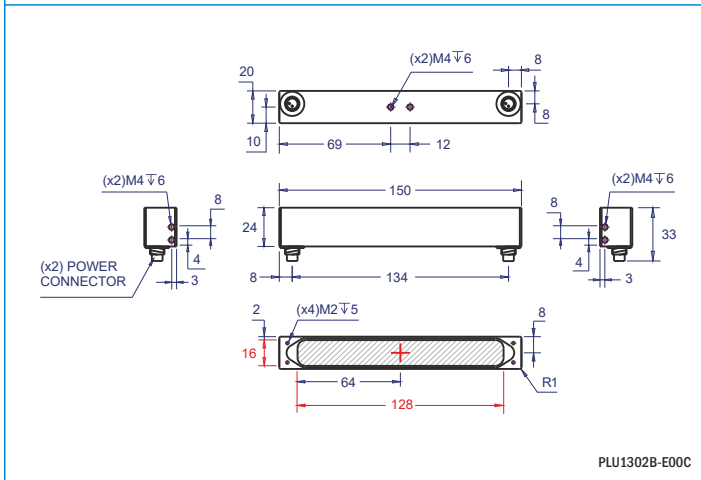
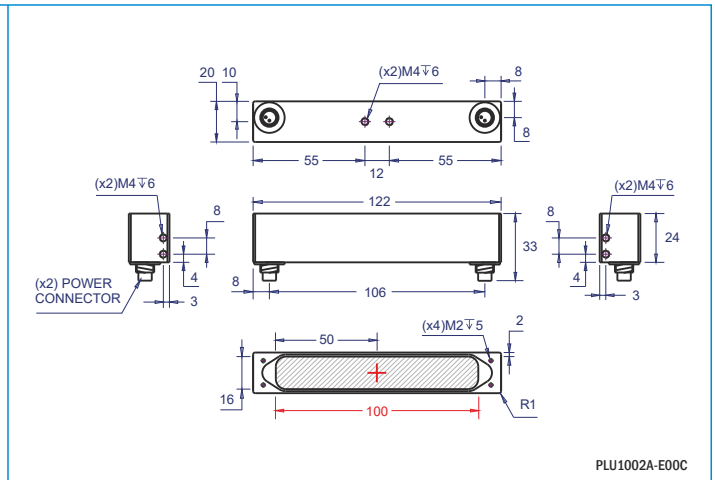
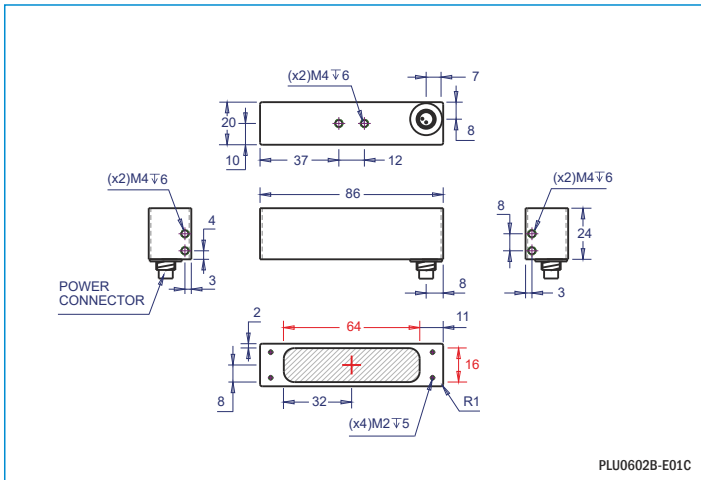

All units in millimeters, if not indicated.

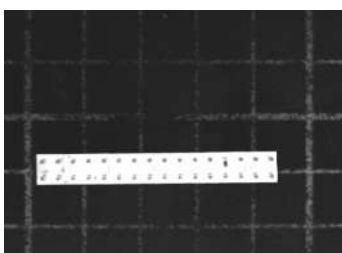

Example of PLU captured image

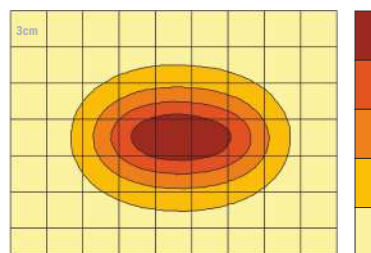

Brightness distribution of PLU1302B-630C@50mm

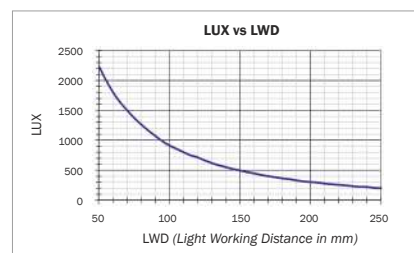

PLU2602A-630C light intensity.

PRA SERIES

















Compact coaxial spot lighting

Designed to replace fiber optic light sources in coaxial/lensing applications. These Spotlights have a tip diameter of 8mm and an emitting surface diameter of 6mm, and can be mounted on the coaxial unit of a macro lens or a telecentric lens. This series features low power consumption.

► Technical specifications¹

Lighting model	PRA0818A
	
Dimensions	Ø8x12
LEDs number	1
RWD (mm)	<50mm
Weight	20g
IP rating	IP40
Mounting holes	BODY Ø8 x 12mm
Connection (Type C/S)	2P aerial male connector PIN 1 = +24V ±3% PIN 2 = 0V
Power cable	VCB Series
Modifiers ⁴	N/A
Accessories ⁵	
iBlueDrive tech.	Inline
iBlueDrive connection	3P aerial male connector. L= 150mm. PIN 1 = +24V ±8% PIN 2 = 0V PIN 3 = Control ⁶
iBlueDrive power cable	VCC Series
iBlueDrive Accessories ⁵	  

► Instantaneous consumption⁷ (max.)

Lighting model	PRA0818A		*WT
TYPE C 24VDC		1.1W	-470C
		1.1W	-525C
		1W	-630C
		1W	-850C
		1.1W	-W00C
TYPE P	No "Type P" standard LED lighting systems in this series		
TYPE S D _{max} = 1/2 ⁰ Ton max= 2ms		2.4W	-470S
		2.4W	-525S
		2.2W	-630S
		4.8W	-850S
		2.4W	-W00S
		N/A	-RGBS
TYPE i ⁸ 		1.2W [5.3W/1W]	-470i
		1.2W [5.3W/1W]	-525i
		1.3W [5.3W/1.1W]	-630i
		1.4W [5.3W/1W]	-850i
		1.2W [5.3W/1W]	-W00i

N/A= Not available

(1) Environmental specifications and iconography legend in additional annex Z1.4 and Z2 respectively.

(2) Prior to manufacturing optional modifications in standard lighting systems. Please, consult the code before ordering (additional annex Z2.1).

(3) Accessories are not included. More information in accessories section.

(4) iBlueDrive control input wiring specifications in additional annex Z1.2.

(5) Bear in mind that consumption table is only to be used as a guide. To refer to real values, please, consult product label when purchasing.

(6) Values of maximum instantaneous consumption of "Type i" lighting systems in **Powered mode (Strobe mode / Continuous mode)**



PRA SERIES

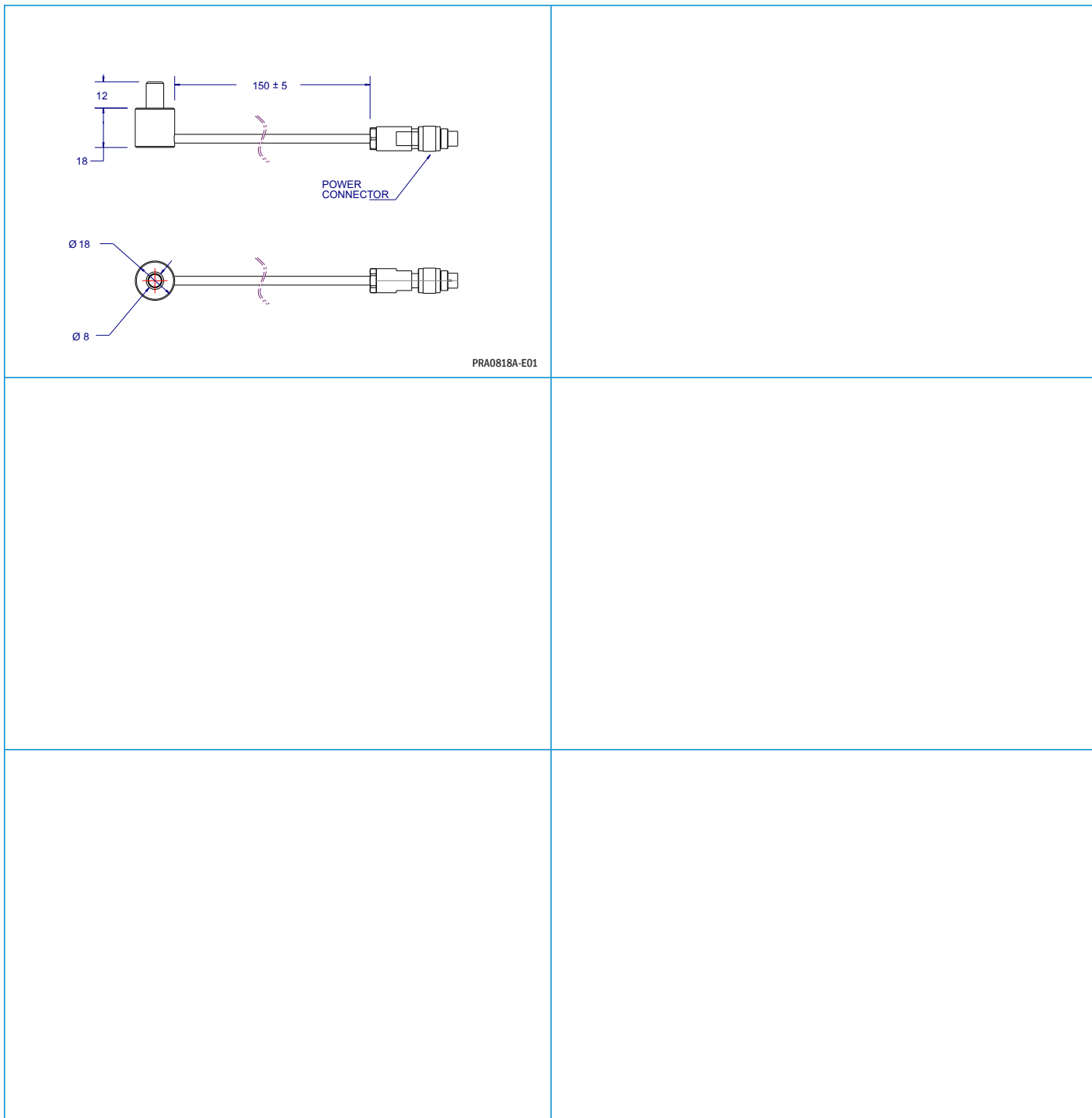









All units in millimeters, if not indicated.

PRC SERIES

Compact high-powered lights projectors



















High power LEDs projector specially designed to illuminate big areas with small lights, due to its angle of emission. This system produces great contrast and emphasizes textures, relieves and finishes that the lighted object could have because any relief, even the smallest one, produces a shadow.

► Technical specifications¹

Lighting model	PRC0604C	PRC0606B	PRC0608C
			
Dimensions	60x50x24	75x66x55	60x50x24
LEDs number	4	4	8
RWD (mm)	>50	>50	>50
Emission angle	Identified as modifier. /AM angle by default. Select another to change it.		
Weight	140g	375g	140g
IP rating	IP65	IP40	IP65
Mounting holes	(x4)M4I6 + (x3)M4I4.5	(x4)M4I6	(x4)M4I6 + (x3)M4I4.5
Connection (Type C/S)	3P aerial male connector. L= 150mm. PIN 1 = +24V ±3% PIN 2 = 0V PIN 3 = Control ²	3P aerial male connector. L= 150mm. PIN 1 = +24V ±8% PIN 2 = 0V PIN 3 = Control ³	N/A
Power cable (Not-included)	VCC Series	VCC Series	N/A
Modifiers⁴			
Accessories⁵			
iBlueDrive tech.	N/A	N/A	Built-in
iBlueDrive connection	N/A	N/A	3P aerial male connector. L= 150mm. PIN 1 = +24V ±8% PIN 2 = 0V PIN 3 = Control ⁶
iBlueDrive power cable (Not-included)	N/A	N/A	VCC Series
iBlueDrive Accessories⁵	N/A	N/A	

► Instantaneous consumption⁷ (max.)

*WT

Lighting model	PRC0604C	PRC0606B	PRC0608C		
TYPE C 24VDC		5.5W	12W	N/A	-400C
		5.5W	10W	N/A	-470C
		5.5W	10W	N/A	-525C
		5.5W	10W	N/A	-630C
		5W	6W	N/A	-850C
		5.5W	10W	N/A	-W00C
TYPE P	No 'Type P' standard LED lighting systems in this series				
TYPE S Dmax= 1/20 Ton max= 2ms		N/A	N/A	N/A	-400S
		N/A	N/A	N/A	-470S
		N/A	N/A	N/A	-525S
		N/A	N/A	N/A	-630S
		N/A	N/A	N/A	-850S
		N/A	N/A	N/A	-W00S
TYPE i⁸ 		N/A	N/A	13W[48W/6.5W]	-400i
		N/A	N/A	13W[48W/6.5W]	-470i
		N/A	N/A	13W[48W/6.5W]	-525i
		N/A	N/A	12W[34W/5.6W]	-630i
		N/A	N/A	7,7W[24W/4.1W]	-850i
		N/A	N/A	13W[48W/6.5W]	-W00i

N/A= Not available

(1) Environmental specifications and iconography legend in additional annex Z1.2 and Z2.

(2) Control input specifications of PRC0604C in additional annex Z1.1.

(3) Control input specifications of PRC0606B in additional annex Z1.1.

(4) Angles of emission of PRC series projectors. If not indicated, default angle will be /AM. Please, consult the code to select a different angle of emission before ordering (additional annex Z2.1).

(5) Accessories are not-included. More information in accessories section.

(6) iBlueDrive control input wiring specifications in additional annex Z1.2.

(7) Bear in mind that consumption table is only to be used as a guide. To refer to real values, please, consult product label when purchasing.

(8) Values of maximum instantaneous consumption of 'Type I' lighting systems in **Powered mode [Strobe mode / Continuous mode]**



PRC SERIES

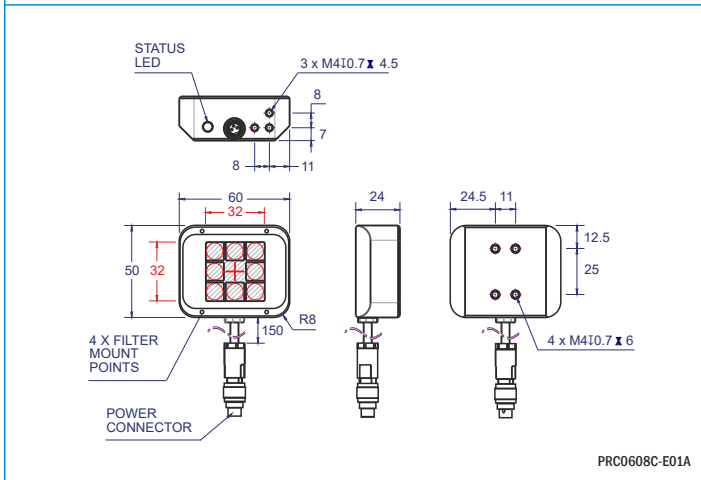
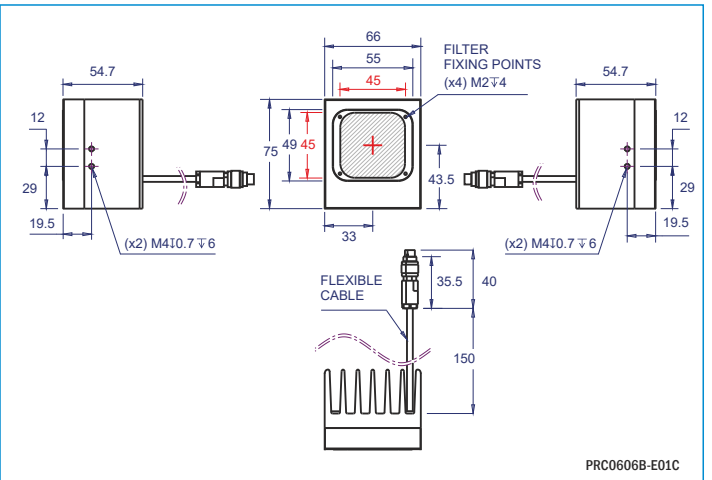
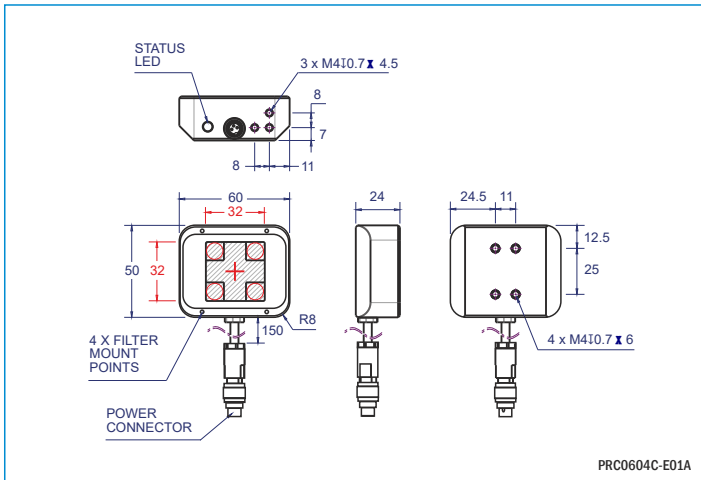

All units in millimeters, if not indicated.



Example of PRC captured image

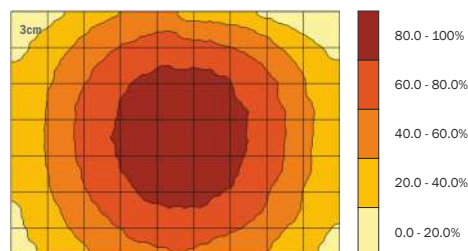

Brightness distribution of PRC0608C-630i/AW@350mm







PRC0608C-630i light intensity.

PRD SERIES























Spot projectors

Ideal lighting system designed for applications in which great amount of light is needed in a small surface. It is used to produce great contrast and emphasize textures, relieves and fissures that the lighted object could have due to the fact that any relief, even the smallest one, produces a shadow.

► Technical specifications¹

Lighting model	PRD0200A	PRD0500B
		
Dimensions	Ø20x58	Ø46x31
RWD (mm)	>50	>50
Weight	75g	95g
IP rating	IP40	IP65
Mounting holes	BODYØ12x39	(x4)M4T6
Connection (Type C/P/S)	BN/RD = +24V ±3% BU/BK = 0V	2P aerial male connector. PIN 1 = +24V ±3% PIN 2 = 0V
Power cable	Pre-cabled with flying leads 2x0.5mm ² L=1.8m	VCB Series (Not-included)
Modifiers³	N/A	
Accessories⁴		
iBlueDrive tech.	inline	inline
iBlueDrive connection	3P aerial male inline connector. L= 715mm. PIN 1 = +24V ±8% PIN 2 = 0V PIN 3 = Control ⁵	3P aerial male inline connector. L= 715mm. PIN 1 = +24V ±8% PIN 2 = 0V PIN 3 = Control ⁵
iBlueDrive power cable (Not-included)	VCC Series	VCC Series
iBlueDrive accessories⁴		

► Instantaneous consumption⁶ (max.)

Lighting model	PRD0200A	PRD0500B	*WT
TYPE C 24VDC	 0.5W	1.3W	-470C
	 0.2W	0.6W	-525C
	 0.5W	2W	-630C
	 0.5W	1.6W	-850C
TYPE P D _{max} = 1/2 Ton max= 60s	 0.5W	1.6W	-365P
	 0.5W	1.6W	-400P
	 0.5W	1.6W	-W00P
	 90mA/2.2W	265mA/6.4W	-365S
TYPE S D _{max} = 1/20 Ton max= 2ms	 90mA/2.2W	265mA/6.4W	-400S
	 90mA/2.2W	265mA/6.4W	-470S
	 55mA/1.3W	165mA/4W	-525S
	 90mA/2.2W	265mA/6.4W	-630S
	 210mA/5W	420mA/10W	-850S
	 90mA/2.2W	265mA/6.4W	-W00S
	 0.8W[2.9W/0.7W]	1.3W[7.7W/1.1W]	-365i
	 1.0W[2.9W/0.7W]	1.9W[7.7W/1.2W]	-400i
TYPE i⁷ 	 0.9W[2.9W/0.8W]	1.8W[7.7W/1.3W]	-470i
	 0.8W[1.7W/0.7W]	1.5W[4.1W/1.1W]	-525i
	 1.2W[2.9W/1.0W]	2.6W[7.7W/1.9W]	-630i
	 1.8W[5.3W/1.2W]	3.1W[10W/1.9W]	-850i
	 1.0W[2.9W/0.7W]	1.9W[7.7W/1.2W]	-W00i

(1) Environmental specifications and iconography legend in additional annex Z1.4 and Z2 respectively.

(2) IP43 if the system is positioned so that the light falls vertically.

(3) Prior to manufacturing optional modifications in standard lighting systems. Please, consult the code before ordering (additional annex Z2.1).

(4) Accessories are not-included. More information in accessories section.

(5) iBlueDrive control input wiring specifications in additional annex Z1.2.

(6) Bear in mind that consumption table is only to be used as a guide. To refer to real values, please, consult product label when purchasing.

(7) Values of maximum instantaneous consumption of 'Type i' lighting systems in Powered mode [Strobe mode / Continuous mode]



PRD SERIES

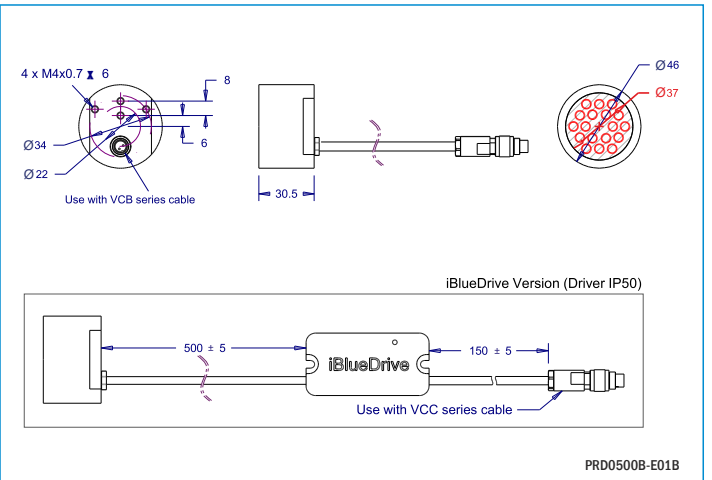
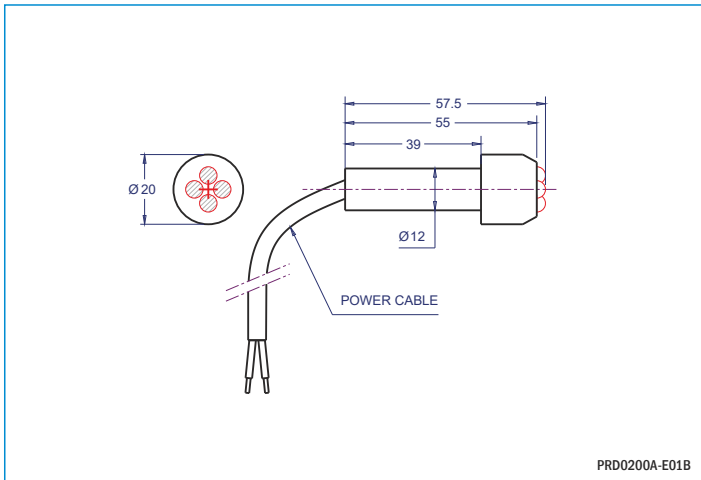

All units in millimeters, if not indicated.

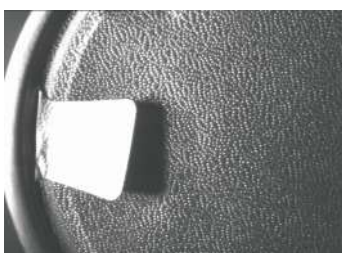

Example of PRD captured image

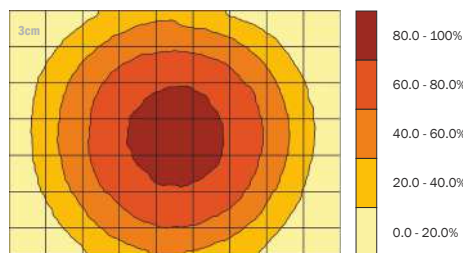

Brightness distribution of PRD0500B-630C@350mm

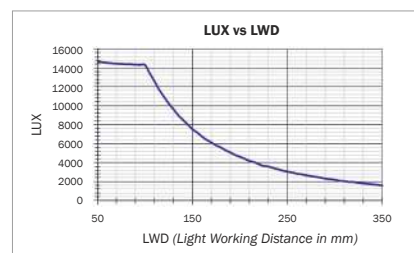

PRD0500B-630C light intensity.





PRF SERIES

Adjustable focus lens projectors















Ideal punctual projector system with adjustable focus lens from 10mm to more than 2 meters of distance. Designed for illuminating small areas and focusing the light from long distances. It can be used as a collimated backlight.

Compact and easy to fit into tight spaces. These lighting system provide a directional spot light headlining shadows, reliefs and textures of illuminated objects.

► Technical specifications¹

Lighting model	PRF0103A
	
Dimensions	Ø30 x 43.6mm
Active surface	Ø25
RWD (mm)	>10
Weight	101g
IP rating	Ip40
Mounting holes	(x3)M4I6
Connection (Type C)	3P aerial male connector. L= 150mm. PIN 1 = +24V ±8% PIN 2 = 0V PIN 3 = Control ²
Power cable (Not-included)	VCC Series
Modifiers ³	
Accessories ⁴	
iBlueDrive tech.	inline
iBlueDrive connection	3P aerial male inline connector. L= 715mm. PIN 1 = +24V ±8% PIN 2 = 0V PIN 3 = Control ⁵
iBlueDrive power cable (Not-included)	VCC Series
iBlueDrive accessories ⁴	

► Instantaneous consumption⁵ (max.)

Lighting model	PRF0103A		*WT
TYPE C 24VDC		2W	-365C
		2W	-400C
		2W	-470C
		2W	-525C
		2W	-630C
		2W	-850C
		2W	-W00C
TYPE P	No "Type P" standard LED lighting systems in this series		
TYPE S	No "Type S" standard LED lighting systems in this series		
TYPE i ⁶ 		5.9W[24W/4.1W]	-365i
		5.9W[24W/4.1W]	-400i
		5.9W[24W/4.1W]	-470i
		5.9W[24W/4.1W]	-525i
		5.9W[17W/4.1W]	-630i
		5.9W[24W/4.1W]	-850i
		5.9W[24W/4.1W]	-W00i

(1) Environmental specifications and iconography legend in additional annex Z1.4 and Z2 respectively.

(2) Prior to manufacturing optional modifications in standard lighting systems. Please, consult the code before ordering (additional annex Z2.1).

(3) Accessories are not-included. More information in accessories section.

(4) iBlueDrive control input wiring specifications in additional annex Z1.2.

(5) Bear in mind that consumption table is only to be used as a guide. To refer to real values, please, consult product label when purchasing.

(6) Values of maximum instantaneous consumption of "Type i" lighting systems in **Powered mode [Strobe mode / Continuous mode]**



PRF SERIES

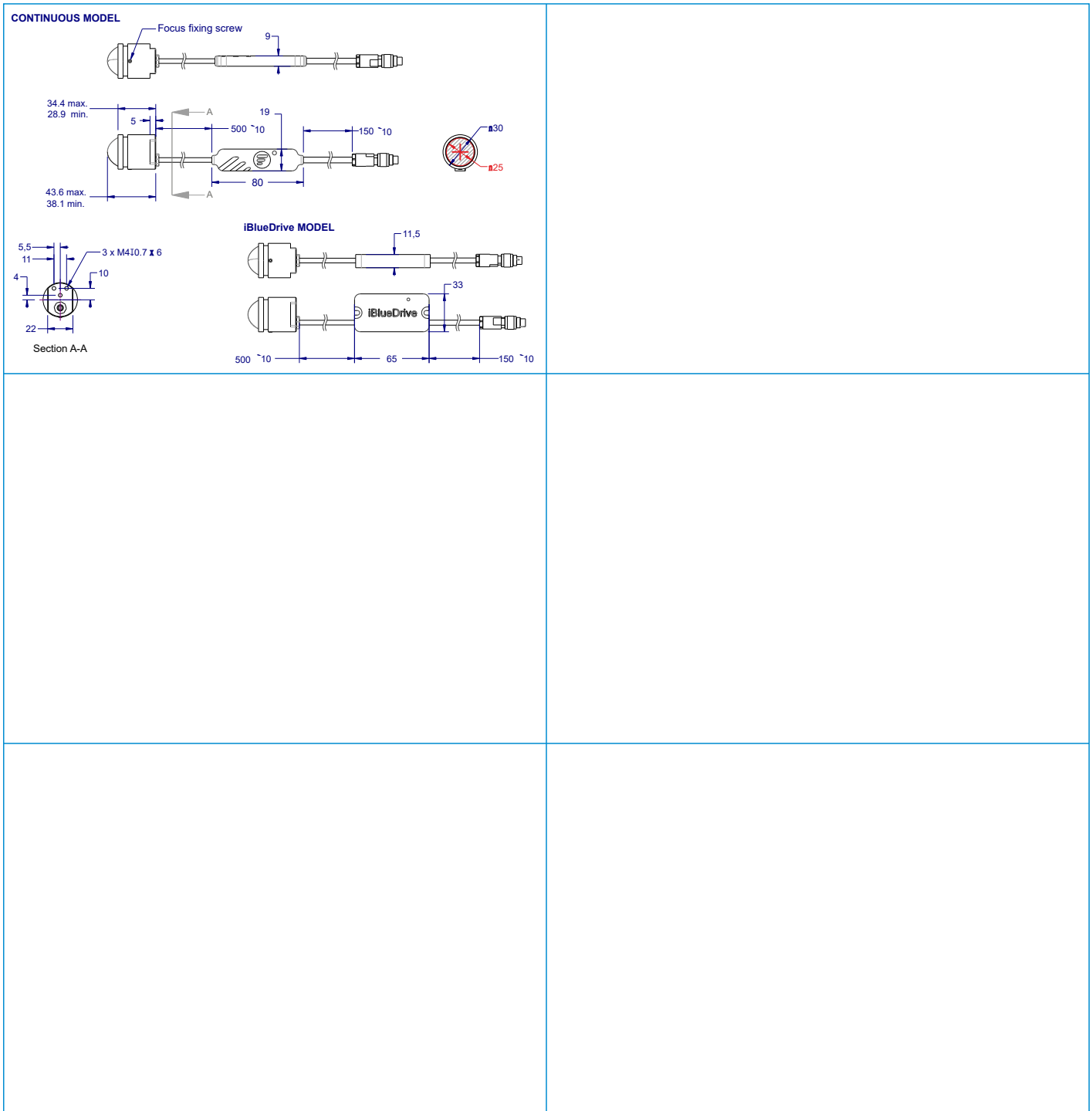

All units in millimeters, if not indicated.

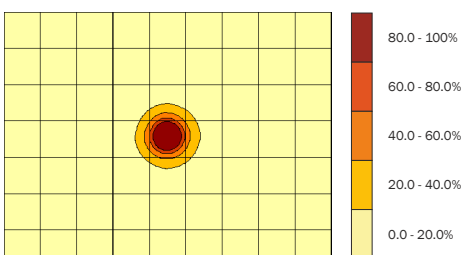

Brightness distribution of PRF0103A-W00i-5mm-aperture@150mm

PRH SERIES

High-powered lights projectors















High-powered lights projectors with different angles of emission ideal to illuminate small and big surfaces. The versatility of this product can be used in a wide variety of applications. This system is used to emphasize reliefs and textures, reading products labels and marks, despalletising and assembly verification on large components, amongst other uses.

► Technical specifications¹

Lighting model	PRH0104A	PRH1612A
		
Dimensions	Ø40x80	125x125x34.5
Active surface	Ø22	115x115
RWD (mm)	>40	>100
Weight	150g	794g
IP rating	IP65	IP65
Mounting holes	(x2)M4I5	(x10)M4I6
Connection (Type C)	3P aerial male connector. L= 150mm. PIN 1 = +24V ±8% PIN 2 = 0V PIN 3 = Control ²	3P aerial male connector. L= 150mm. PIN 1 = +24V ±8% PIN 2 = 0V PIN 3 = Control ²
Power cable (Not-included)	VCC Series	VCC Series
Modifiers ³		
Accessories ⁴		
iBlueDrive tech.	Built-in	Built-in
iBlueDrive connection	3P aerial male inline connector. L= 715mm. PIN 1 = +24V ±8% PIN 2 = 0V PIN 3 = Control ⁵	3P aerial male inline connector. L= 715mm. PIN 1 = +24V ±8% PIN 2 = 0V PIN 3 = Control ⁵
iBlueDrive power cable (Not-included)	VCC Series	VCC Series
iBlueDrive accessories ⁴		

► Instantaneous consumption⁵ (max.)

*WT

Lighting model	PRH0104A	PRH1612A		
TYPE C 24VDC		2.5W	20W	-365C
		2.5W	20W	-400C
		2.5W	20W	-470C
		2.5W	20W	-525C
		2.5W	18W	-630C
		2.5W	18W	-850C
		2.5W	18W	-W00C
TYPE P	No "Type P" standard LED lighting systems in this series			
TYPE S	No "Type S" standard LED lighting systems in this series			
TYPE i ⁶ 		1.9W[24W/1.2W]	30W[96W/15W]	-365i
		1.9W[24W/1.2W]	30W[96W/15W]	-400i
		1.9W[24W/1.2W]	30W[96W/15W]	-470i
		1.9W[24W/1.2W]	30W[96W/15W]	-525i
		1.9W[17W/1.2W]	30W[96W/15W]	-630i
		1.9W[24W/1.2W]	24W [48W/12W]	-850i
		1.9W[24W/1.2W]	24W[96W/12W]	-W00i

(1) Environmental specifications and iconography legend in additional annex Z1.4 and Z2 respectively.

(2) Control input specifications of PRH series in additional annex Z1.1.

(3) Prior to manufacturing optional modifications in standard lighting systems including angles of emission of PRH series projectors. If not indicated, default angle will be /AM. Please, consult the code to select a different angle of emission or another optional

*ORDER REFERENCE = Lighting model + WT / MODIFIERS

modification before ordering (additional annex Z2.1).

(4) Accessories are not-included. More information in accessories section.

(5) Bear in mind that consumption table is only to be used as a guide. To refer to real values, please, consult product label when purchasing.

(6) Values of maximum instantaneous consumption of "Type i" lighting systems in Powered mode [Strobe mode / Continuous mode]



PRH SERIES

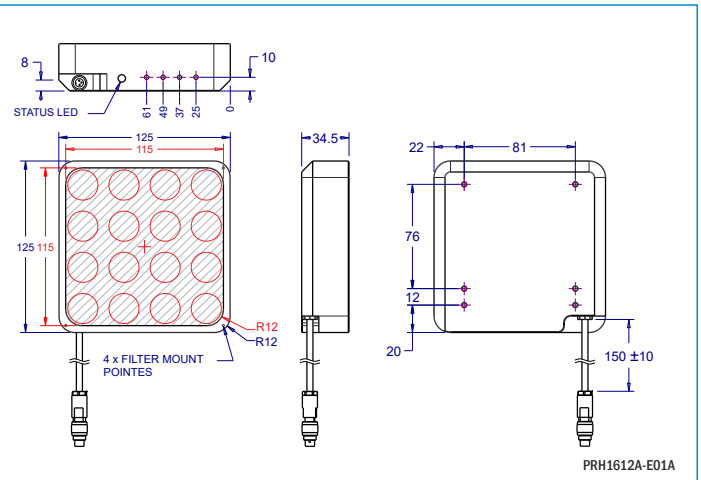
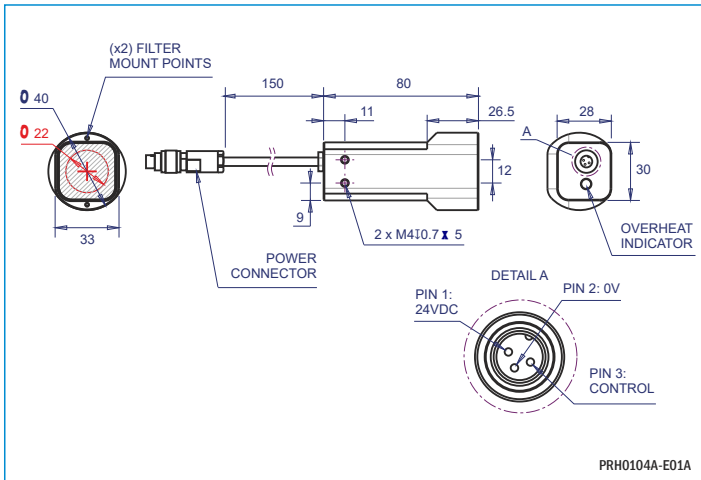

All units in millimeters, if not indicated.

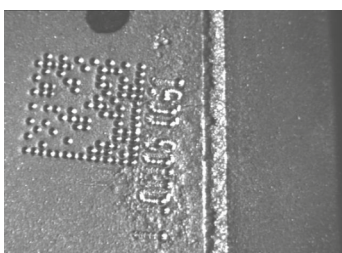

Example of PRH captured image

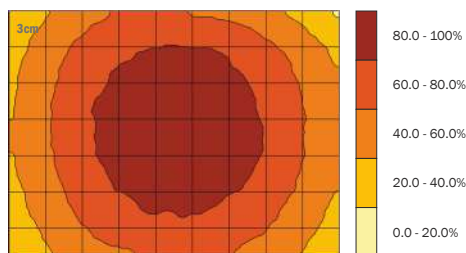

Brightness distribution of PRH0104A-630C/AW@200mm

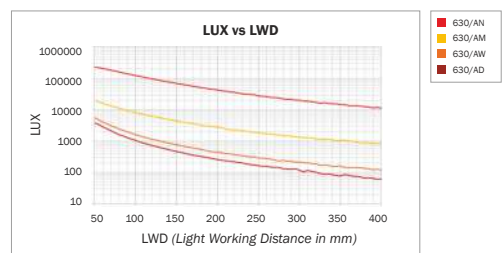

PRH0104A-630C light intensity.

PRK SERIES

Harsh environment washdown HP projectors







The IP69K high-powered projector is made of 316L stainless steel. It is specially designed to operate in food applications preventing material accumulation (including bacterium). Adapted to environments with constraints, submitted to foam and high pressure cleaning. Meets FDA and IP69K compliancy.

► Technical specifications¹

Lighting model	PRK0608A
	
Dimensions	73x73x24.8
Active surface	32x32
RWD (mm)	>50
Weight	673g
IP rating	IP69K
Mounting holes	(x2)M4I6
Modifiers ³	
Accessories ⁴	NO
iBlueDrive tech.	Built-in
iBlueDrive connection	RD = +24V ±8% BK = 0V GN = Control
iBlueDrive power cable	Pre-cabled with flying leads 2X0.5mm ² + 1x0.2mm ² Length=5m
iBlueDrive accessories ⁴	

► Instantaneous consumption⁵ (max.)

*WT

Lighting model	PRK0608A		
TYPE C	No 'Type C' standard LED lighting systems in this series		
TYPE P	No 'Type P' standard LED lighting systems in this series		
TYPE S	No 'Type S' standard LED lighting systems in this series		
		13W[48W/6.5W]	-400i
		13W[48W/6.5W]	-470i
		13W[48W/6.5W]	-525i
		13W[34W/6.5W]	-630i
		13W[48W/6.5W]	-850i
		13W[48W/6.5W]	-W00i

(1) Environmental specifications and iconography legend in additional annex Z1.4 and Z2 respectively.

(2) Control input specifications of PRK series in additional annex Z1.1.

(3) Prior to manufacturing optional modifications in standard lighting systems including angles of emission of PRH series projectors. If not indicated, default angle will be /AM. Please, consult the code to select a different angle of emission or another optional

modification before ordering (additional annex Z2.1).

(4) Accessories are not-included. More information in accessories section.

(5) Bear in mind that consumption table is only to be used as a guide. To refer to real values, please, consult product label when purchasing.

(6) Values of maximum instantaneous consumption of 'Type I' lighting systems in Powered mode [Strobe mode / Continuous mode]



PRK SERIES

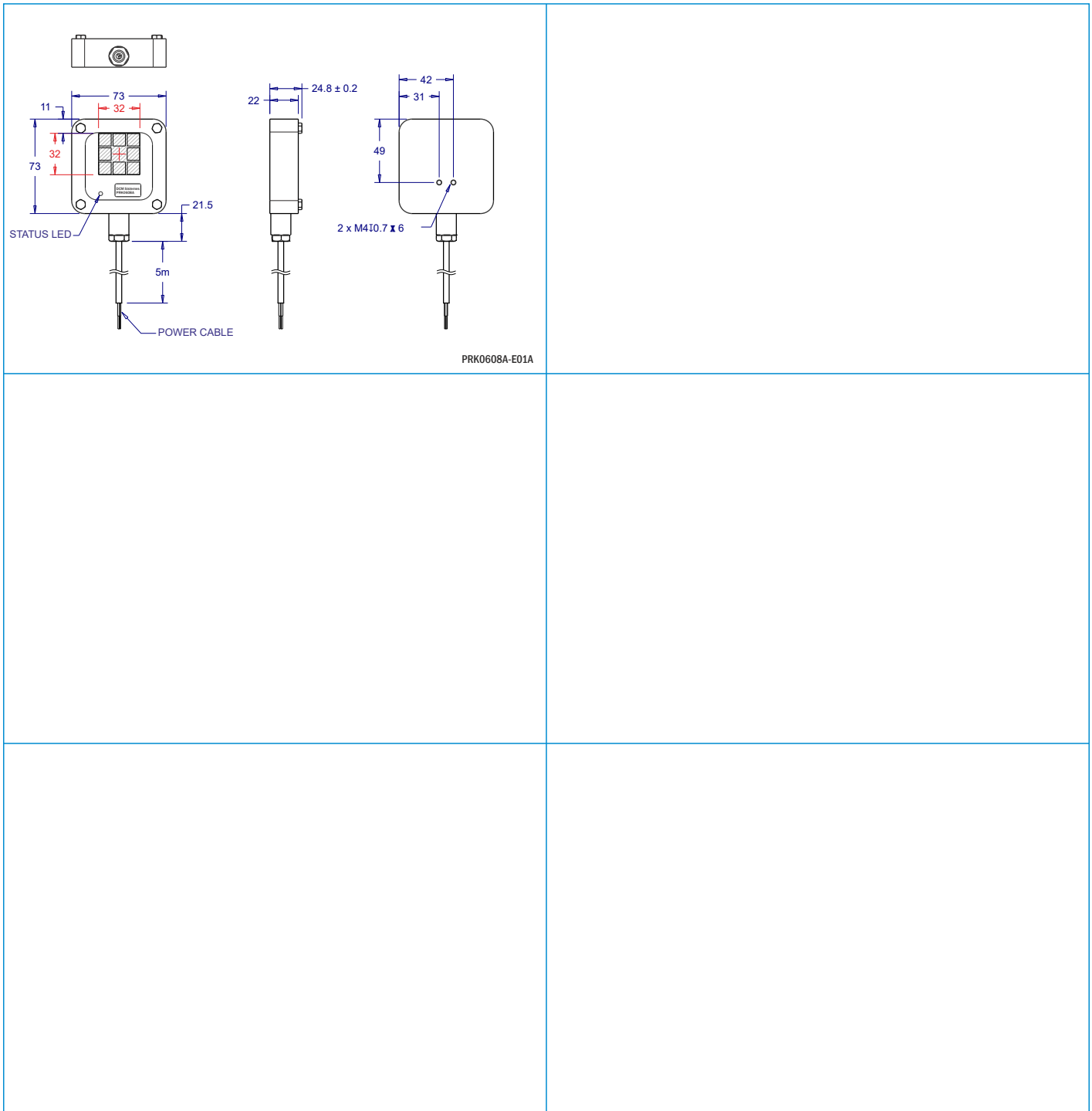

All units in millimeters, if not indicated.



Example of PRK captured image

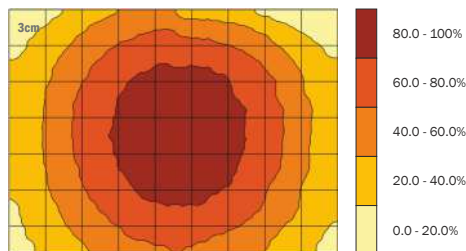

Brightness distribution of PRK0608A-630i/AW@350mm

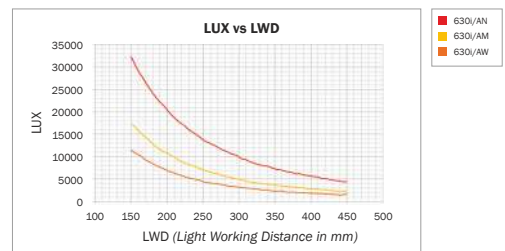

PRK0608A-630i light intensity.

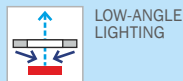





PRL SERIES

Line lights projectors

High intensity LED projectors which produce a line of intensive and narrow light. Specially designed for obtaining the ideal light for linear cameras. Otherwise, with matricial cameras, allow darkfield lighting (highlighting the small reliefs and cracks) in large areas or long distances.

Technical specifications¹





Lighting model	PRLnn00B*
	 
Dimensions	Length (L) = (nn x 201) + 6 Width = 35
Active surface	Length (L) = (nn x 201)
RWD (mm)	F1 = 50mm F2 = 150mm F3 = infinite
Focal length	Identified as modifier. /F1 focal length by default. Select another focal length or diffuse emission to change it.
Weight (g)	66 + (584,5 x nn)
IP rating	IP40
Mounting holes	nn x M4x0.7I
Connection (Type C)	BN = +24V ±3% BU = 0V
Power cable	Pre-cabled with flying leads 2x1mm ² Length=1.8m
Modifiers ²	
Accessories ³	
iBlueDrive tech.	N/A

(*) Customizable lighting system composed by segments of 201mm of light emission window. The required length for each application is assembled from manufacturing preserving light homogeneity. The lighting model name will depend on the number of segments and will be composed as it is shown in the table below:

Lighting model	nn	L = nn x 201 (Length)
PRLO200B	02	201
PRL0400B	04	402
PRLnn00B	nn	(nn x 201)
PRL3000B	30	3015

Instantaneous consumption⁴ (max.)

*WT

Lighting model	PRLnn00B*	
TYPE C 24VDC		30W x nn -470C
		30W x nn -525C
		22W x nn -630C
		18W x nn -850C
		30W x nn -W00C
TYPE P	No 'Type P' standard LED lighting systems in this series	
TYPE S	No 'Type S' standard LED lighting systems in this series	
TYPE i	No 'Type i' standard LED lighting systems in this series	

(1) Environmental specifications and iconography legend in additional annex Z1.4 and Z2 respectively.

(2) Focal Lengths or diffuse emission of PRL series projectors, identified as modifiers. If not indicated, default modifier will be /F1. Please, consult the code to select a different one before ordering (additional annex Z2.1).

(3) Accessories are not-included. More information in accessories section.

(4) Bear in mind that consumption table is only to be used as a guide. To refer to real values, please, consult product label when purchasing.



PRL SERIES

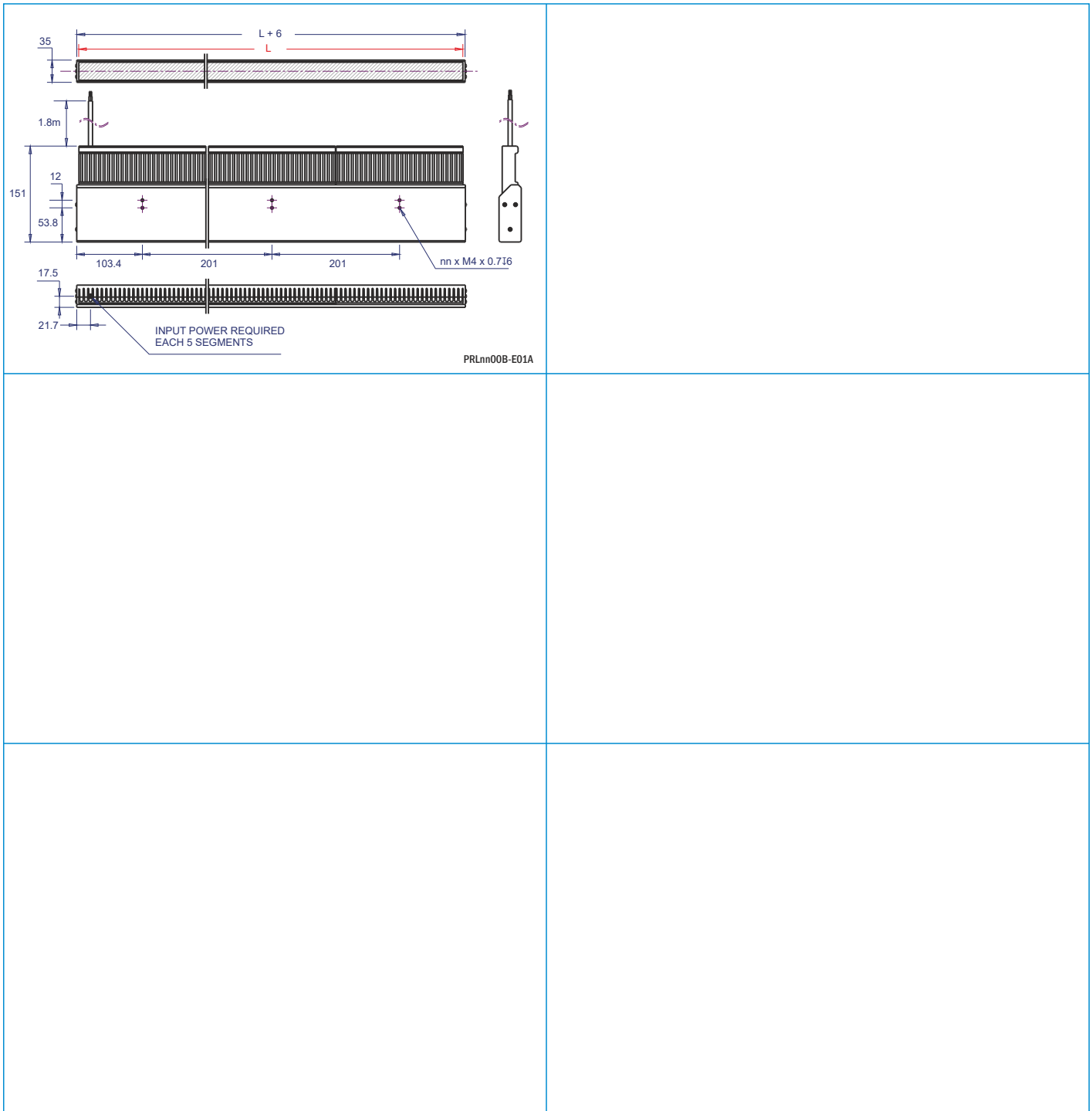

All units in millimeters, if not indicated.

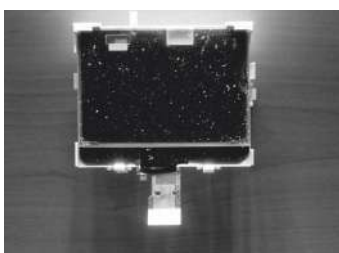

Example of PRL captured image

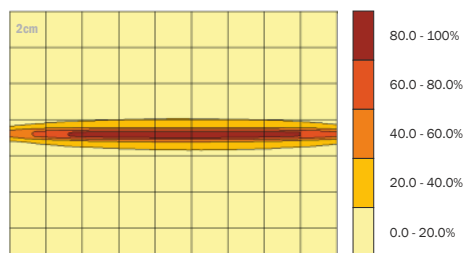

Brightness distribution of PRL0200B-W00C/F1@50mm

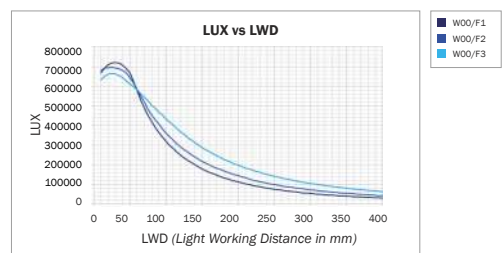

PRL0200B-W00C light intensity.

PRY SERIES



























Direct lights projectors

Large punctual light high power projector, used to illuminate non-reflecting objects. This system produces great contrast and emphasizes textures, relieves and fissures that the lighted object could have due to the fact that any relief, even the smallest one, produces a shadow.

► Technical specifications¹

Lighting model	PRY0504A	PRY0906A	PRY1609A
			
Dimensions	47x56x18	101x114x22	128x198x22
Active surface	43x45	68x86	158x86
RWD (mm)	>50	>50	>50
Weight	70g	375g	805g
IP rating	IP40	IP40	IP40
Mounting holes	(x4)M3I5	(x4)M4I6	(x9)M4I6
Connection (Type C/P/S)	2P male chassis connector PIN 1 = +24V ±3% PIN 2 = 0V	2P male chassis connector PIN 1 = +24V ±3% PIN 2 = 0V	2P male chassis connector PIN 1 = +24V ±3% PIN 2 = 0V
Power cable (Not-included)	VCB Series	VCB Series	VCB Series
Modifiers²		N/A	N/A
Accessories³			
iBlueDrive tech.	inline	Built-in	Built-in
iBlueDrive connection	3P aerial male inline connector. L= 715mm. PIN 1 = +24V ±8% PIN 2 = 0V PIN 3 = Control ⁴	3P male chassis connector PIN 1 = +24V ±8% PIN 2 = 0V PIN 3 = Control ⁴	3P male chassis connector PIN 1 = +24V ±8% PIN 2 = 0V PIN 3 = Control ⁴
iBlueDrive power cable (Not-included)	VCC Series	VCC Series	VCC Series
iBlueDrive accessories³			

► Instantaneous consumption⁵ (max.)

Lighting model	PRY0504A	PRY0906A	PRY1609A	*WT	
TYPE C 24VDC		N/A	6.4W	14W	-470C
		1.7W	3.4W	7.6W	-525C
		2.6W	6.4W	14W	-630C
		2.8W	6.4W	14W	-850C
TYPE P 24VDC Dmax= 1/2 Ton max= 60s		3.1W	8.4W	19W	-365P
		3.1W	8.4W	19W	-400P
		4.2W	N/A	N/A	-470P
		1.7W	N/A	N/A	-525P
		4.2W	8.4W	19W	-W00P
		4.2W	8.4W	19W	-W00P
TYPE S Dmax= 1/20 Ton max= 2ms		705mA/17W	1410mA/34W	3170mA/76W	-365S
		705mA/17W	1410mA/34W	3170mA/76W	-400S
		705mA/17W	1410mA/34W	3170mA/76W	-470S
		440mA/11W	880mA/21W	1980mA/48W	-525S
		705mA/17W	1410mA/34W	3170mA/76W	-630S
		1045mA/25W	1670mA/40W	3760mA/90W	-850S
		705mA/17W	1410mA/34W	3170mA/76W	-W00S
		705mA/17W	1410mA/34W	3170mA/76W	-W00S
TYPE I⁶ 		2.8W[20W/2W]	5.1W[31W/3.6W]	11W[48W/7.4W]	-365i
		4.3W[20W/2.4W]	8.2W[39W/4.3W]	18W[48W/9.1W]	-400i
		3.9W[20W/2.8W]	7.4W[39W/5.1W]	16W[48W/11W]	-470i
		3.4W[10W/2W]	6.2W[20W/3.6W]	13W[44W/7.4W]	-525i
		6.2W[20W/4.3W]	12W[39W/6.2W]	26W[48W/13W]	-630i
		7.1W[24W/4.1W]	11W[39W/6.2W]	24W[48W/13W]	-850i
		4.3W[20W/2.4W]	8.2W[39W/4.3W]	18W[87W/9.1W]	-W00i
		4.3W[20W/2.4W]	8.2W[39W/4.3W]	18W[87W/9.1W]	-W00i

N/A= Not available

(1) Environmental specifications and iconography legend in additional annex Z1.4 and Z2 respectively.
 (2) Prior to manufacturing optional modifications in standard lighting systems. Please, consult the code before ordering (additional annex Z2.1).
 (3) Accessories are not-included. More information in accessories section.

(4) iBlueDrive control input wiring specifications in additional annex Z1.2.

(5) Bear in mind that consumption table is only to be used as a guide. To refer to real values, please, consult product label when purchasing.

(6) Values of maximum instantaneous consumption of 'Type I' lighting systems in **Powered mode (Strobe mode / Continuous mode)**



PRY SERIES

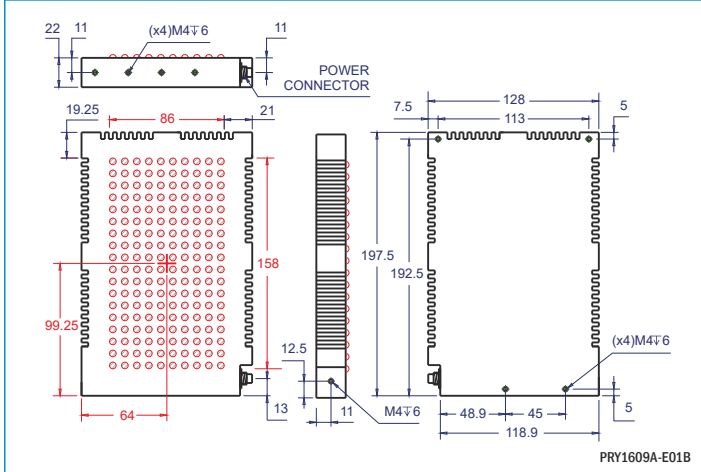
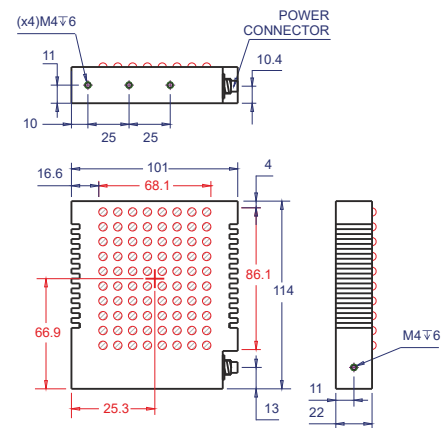
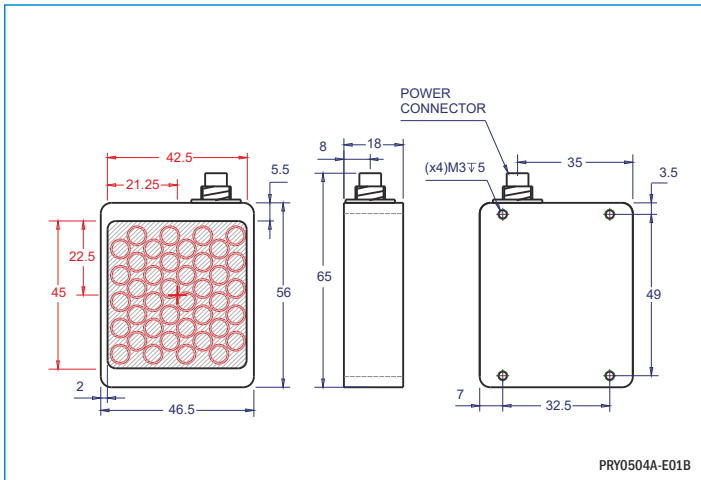

All units in millimeters, if not indicated.

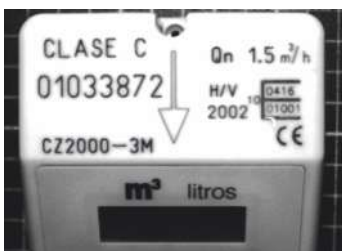

Example of PRY captured image

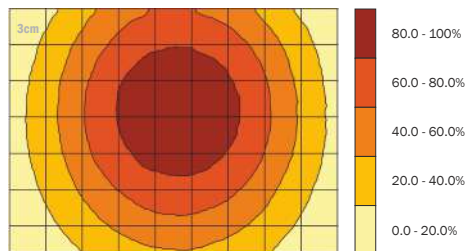

Brightness distribution of PRY1609A-630C@350mm

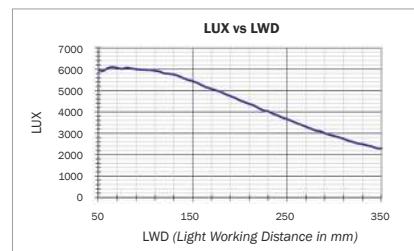

PRY1609A-630C light intensity.

SAC SERIES

Diffuse axial compact lights

Diffused axial compact lighting system that produces a diffused light upcoming from the camera axis which eliminates shines and shadows on reflecting objects.

► Technical specifications¹

Lighting model	SAC0505A	SAC0808A	SAC1010A	SAC3010A
Dimensions	100x61x62	125x87x85	150x112x108	312x100x108
Active surface	52x50	75x75	100x100	100x300
RWD (mm)	<100	<100	<120	<200
Weight	400g	740g	1510g	2375g
IP rating	IP40	IP40	IP40	IP40
Mounting holes	(x4)M4I6	(x4)M4I6	(x8)M4I6	(x8)M4I6
Connection (Type C/S)	2P male chassis connector PIN 1 = +24V ±3% PIN 2 = 0V	2P male chassis connector PIN 1 = +24V ±3% PIN 2 = 0V	2P male chassis connector PIN 1 = +24V ±3% PIN 2 = 0V	2P male chassis connector PIN 1 = +24V ±3% PIN 2 = 0V
Power cable (Not-included)	VCB Series	VCB Series	VCB Series	VCB Series
Modifiers²				
Accessories³				
iBlueDrive tech.	inline	Built-in	Built-in	Built-in
iBlueDrive connection	3P aerial male inline connector. L= 715mm. PIN 1 = +24V ±8% PIN 2 = 0V PIN 3 = Control ⁴	3P male chassis connector PIN 1 = +24V ±8% PIN 2 = 0V PIN 3 = Control ⁴	3P male chassis connector PIN 1 = +24V ±8% PIN 2 = 0V PIN 3 = Control ⁴	3P male chassis connector PIN 1 = +24V ±8% PIN 2 = 0V PIN 3 = Control ⁴
iBlueDrive power cable (Not-included)	VCC Series	VCC Series	VCC Series	VCC Series
iBlueDrive accessories³				

► Instantaneous consumption⁵ (max.)

*WT

Lighting model	SAC0505A	SAC0808A	SAC1010A	SAC3010A		
TYPE C 24VDC		3.8W	8.9W	8.5W	26W	-470C
		4.1W	9.2W	9.5W	29W	-525C
		4.2W	4.8W	9.5W	29W	-630C
		4.2W	4.8W	9.5W	29W	-850C
		4.1W	9.2W	9.5W	29W	-W00C
TYPE P	No "Type P" standard LED lighting systems in this series					
TYPE S D _{max} = 1/20 Ton max= 2ms		615mA/15W	1410mA/34W	1585mA/38W	1585mA/38W	-470S
		615mA/15W	1410mA/34W	1585mA/38W	1585mA/38W	-525S
		615mA/15W	1410mA/34W	1585mA/38W	1585mA/38W	-630S
		1465mA/35W	1670mA/40W	1585mA/38W	1585mA/38W	-850S
		615mA/15W	1410mA/34W	1585mA/38W	1585mA/38W	-W00S
	700mA/22W channel	1500mA/36W channel	1600mA/38W channel	4800mA/115W channel		-RGBS
TYPE i⁶ 		3.5W[17W/2.6W]	7.4W[39W/5.5W]	8.3W[44W/6.1W]	24W[130W/17W]	-470i
		5.5W[17W/3.8W]	12W[39W/8.2W]	13W[44W/9.1W]	39W[130W/26W]	-525i
		5.5W[17W/3.8W]	12W[39W/8.2W]	13W[44W/9.1W]	39W[130W/26W]	-630i
		11W[34W/5.5W]	12W[39W/6.2W]	13W[48W/9.1W]	39W[144W/26W]	-850i
		5.5W[17W/3.8W]	12W[39W/8.2W]	13W[44W/9.1W]	39W[130W/26W]	-W00i

(1) Environmental specifications and iconography legend in additional annex Z1.4 and Z2 respectively.

(2) Prior to manufacturing optional modifications in standard lighting systems. Please, consult the code before ordering (additional annex Z2.1).

(3) Accessories are not-included. More information in accessories section.

(4) iBlueDrive control input wiring specifications in additional annex Z1.2.

(5) Bear in mind that consumption table is only to be used as a guide. To refer to real values, please, consult product label when purchasing.

(6) Values of maximum instantaneous consumption of "Type i" lighting systems in **Powered mode (Strobe mode / Continuous mode)**



SAC SERIES

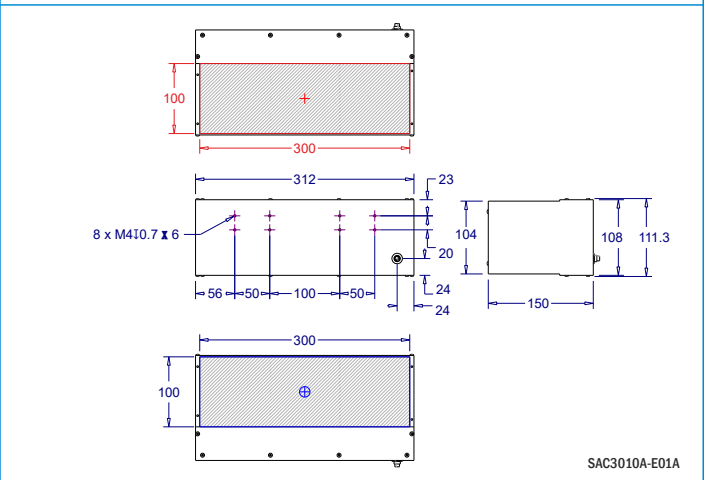
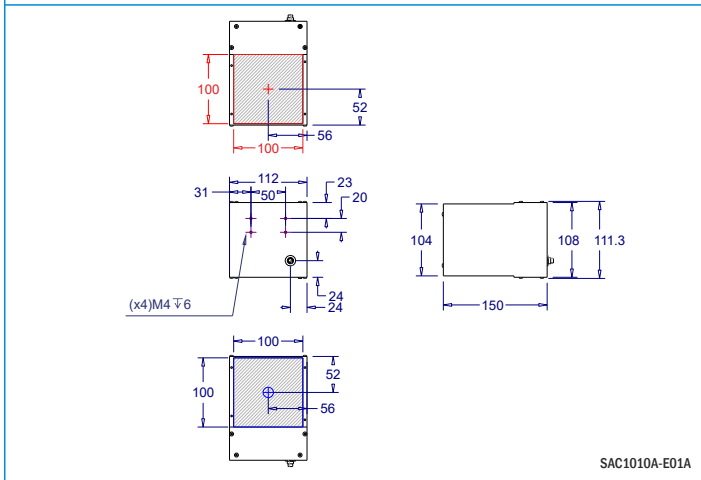
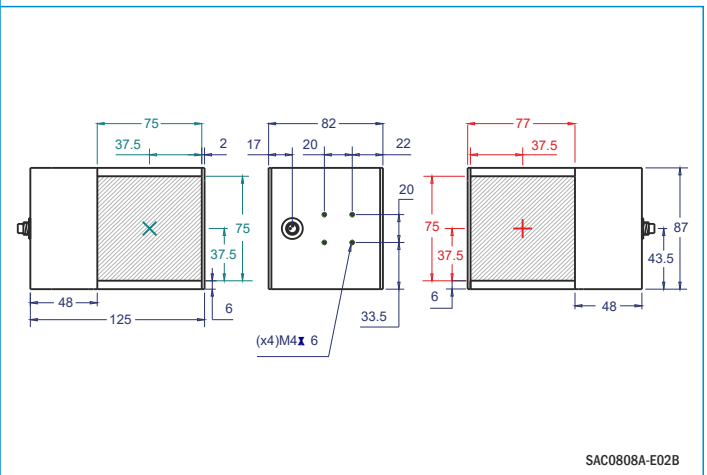
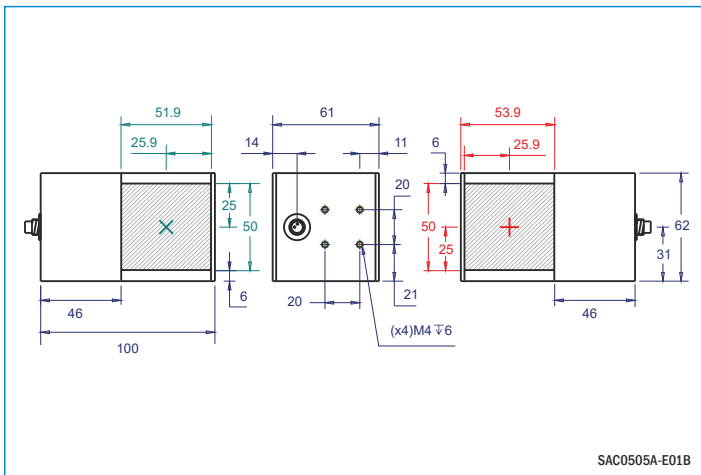

All units in millimeters, if not indicated.



Example of SAC captured image

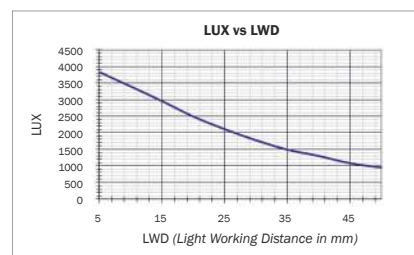
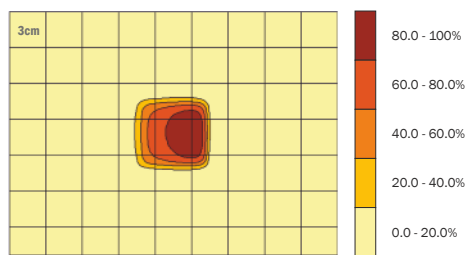

SAL SERIES

















90° diffuse axial lights

Ultra uniform axial system. The camera sees the object reflected on the same beamsplitter through which light falls into the piece. Very useful when a diffuse light illumination is needed to improve homogeneity and also avoid shines and shadows. Moreover, due to the 90° camera placing, total height setup is reduced.

► Technical specifications¹

Lighting model	SAL0202A	SAL0504A
		
Dimensions	38x25x30	83x63x77
Active surface	17x17	49x40
RWD (mm)	<100	<100
Weight	65g	330g
IP rating	IP40	IP40
Mounting holes	(x2)M3I5	(x2)M4I6
Connection (Type C/S)	BN = +24V ±3% BU = 0V	2P male chassis connector PIN 1 = +24V ±3% PIN 2 = 0V
Power cable	Pre-cabled with flying leads 2x0.22mm ² L=1.8m	VCB Series (Not-included)
Modifiers²		
Accessories³		
iBlueDrive tech.	inline	inline
iBlueDrive connection	3P aerial male inline connector. L= 715mm. PIN 1 = +24V ±8% PIN 2 = 0V PIN 3 = Control ⁴	3P aerial male inline connector. L= 715mm. PIN 1 = +24V ±8% PIN 2 = 0V PIN 3 = Control ⁴
iBlueDrive power cable (Not-included)	VCC Series	VCC Series
iBlueDrive accessories³		

► Instantaneous consumption⁵ (max.)

Lighting model	SAL0202A	SAL0504A	*WT	
TYPE C 24VDC		0.6W	6.1W	-470C
		0.6W	6.1W	-525C
		0.6W	6.1W	-630C
		0.6W	6.1W	-850C
		0.6W	6.1W	-W00C
TYPE P	No "Type P" standard LED lighting systems in this series			
TYPE S D _{max} = 1/2 ₀ Ton max= 2ms		90mA/2.2W	880mA/21W	-470S
		90mA/2.2W	880mA/21W	-525S
		90mA/2.2W	880mA/21W	-630S
		210mA/5W	2090mA/50W	-850S
		90mA/2.2W	880mA/21W	-W00S
TYPE i⁶ 		0.9W[2.9W/0.8W]	4.8W[24W/3.6W]	-470i
		1.2W[2.9W/1W]	7.7W[24W/5.3W]	-525i
		1.2W[2.9W/1W]	7.7W[24W/5.3W]	-630i
		1.4W[5.3W/1W]	15W[48W/7.7W]	-850i
		1.2W[2.9W/1W]	7.7W[24W/5.3W]	-W00i

(1) Environmental specifications and iconography legend in additional annex Z1.4 and Z2 respectively.

(2) Prior to manufacturing optional modifications in standard lighting systems. Please, consult the code before ordering (additional annex Z2.1).

(3) Accessories are not-included. More information in accessories section.

(4) iBlueDrive control input wiring specifications in additional annex Z1.2.

(5) Bear in mind that consumption table is only to be used as a guide. To refer to real values, please, consult product label when purchasing.

(6) Values of maximum instantaneous consumption of "Type i" lighting systems in **Powered mode (Strobe mode / Continuous mode)**



SAL SERIES

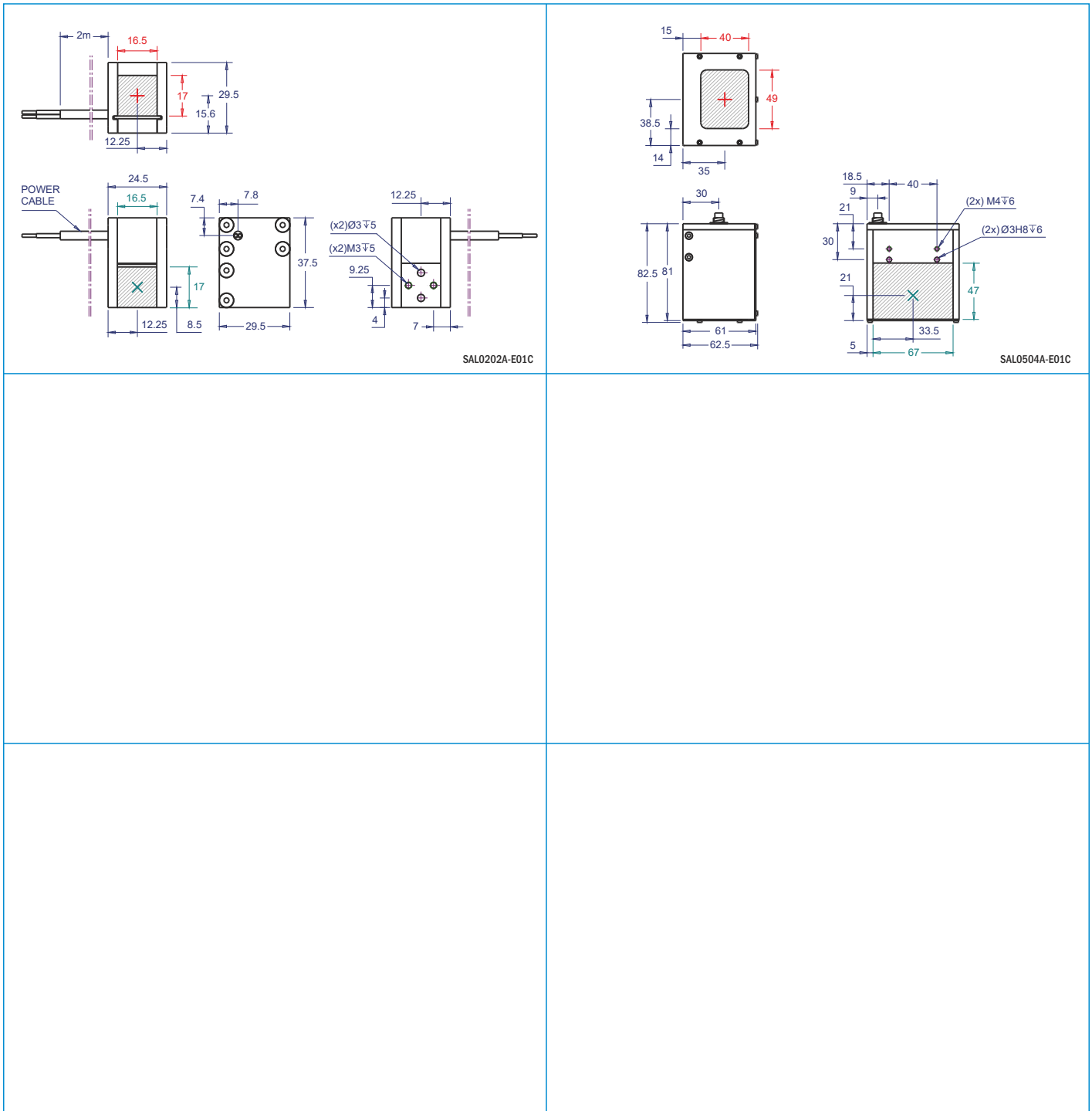

All units in millimeters, if not indicated.



Example of SAL captured image

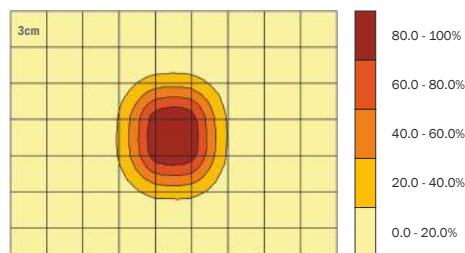

Brightness distribution of SAL0504A-630C@50mm

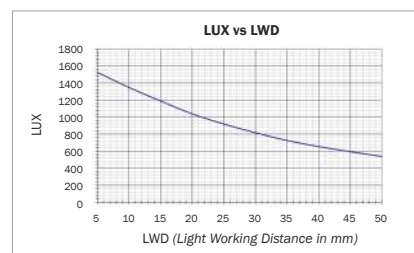

SAL0504A-630C light intensity.

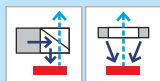

LIGHTING COMBINATION



AXIAL LIGHTING



RADIAL LIGHTING

SAR SERIES





SAR21.01

Diffuse ring and 90° axial lights

Linear projector with high illumination for larger areas, longer distances and better performances.

This system produces great contrast and emphasizes textures, relieves and fissures that the lighted object could have.

Technical specifications¹

Lighting model	SAR0504A
  	
Dimensions	80x70x96
Active surface	74x62
RWD (mm)	<100
Weight	356g
IP rating	IP40
Mounting holes	(x2)M4T6
Connection (Type C/S)	3P male chassis connector PIN 1 = +24V ±3% PIN 2 = 0V RING PIN 3 = 0V AXIAL
Power cable (Not-included)	VCC Series
Modifiers ²	N/A
Accessories ³	
iBlueDrive tech.	N/A

Instantaneous consumption⁴ (max.)

*WT

Lighting model	SAR0504A-RING / SAR0504A-AXIAL			
TYPE C 24VDC		3.6W	6.1W	-470C
		3.6W	6.1W	-525C
		3.6W	6.1W	-630C
		3.6W	6.1W	-850C
		3.6W	6.1W	-W00C
TYPE P	No "Type P" standard LED lighting systems in this series			
TYPE S D _{max} = 1/20 Ton max= 2ms		530mA/13W	880mA/21W	-470S
		530mA/13W	880mA/21W	-525S
		530mA/13W	880mA/21W	-630S
		1255mA/30W	2090mA/50W	-850S
		530mA/13W	880mA/21W	-W00S
TYPE i	No "Type i" standard LED lighting systems in this series			

(1) Environmental specifications and iconography legend in additional annex Z1.4 and Z2 respectively.

(2) Prior to manufacturing optional modifications in standard lighting systems. Please, consult the code before ordering (additional annex Z2.1).

(3) Accessories are not-included. More information in accessories section.

(4) Bear in mind that consumption table is only to be used as a guide. To refer to real values, please, consult product label when purchasing.



SAR SERIES

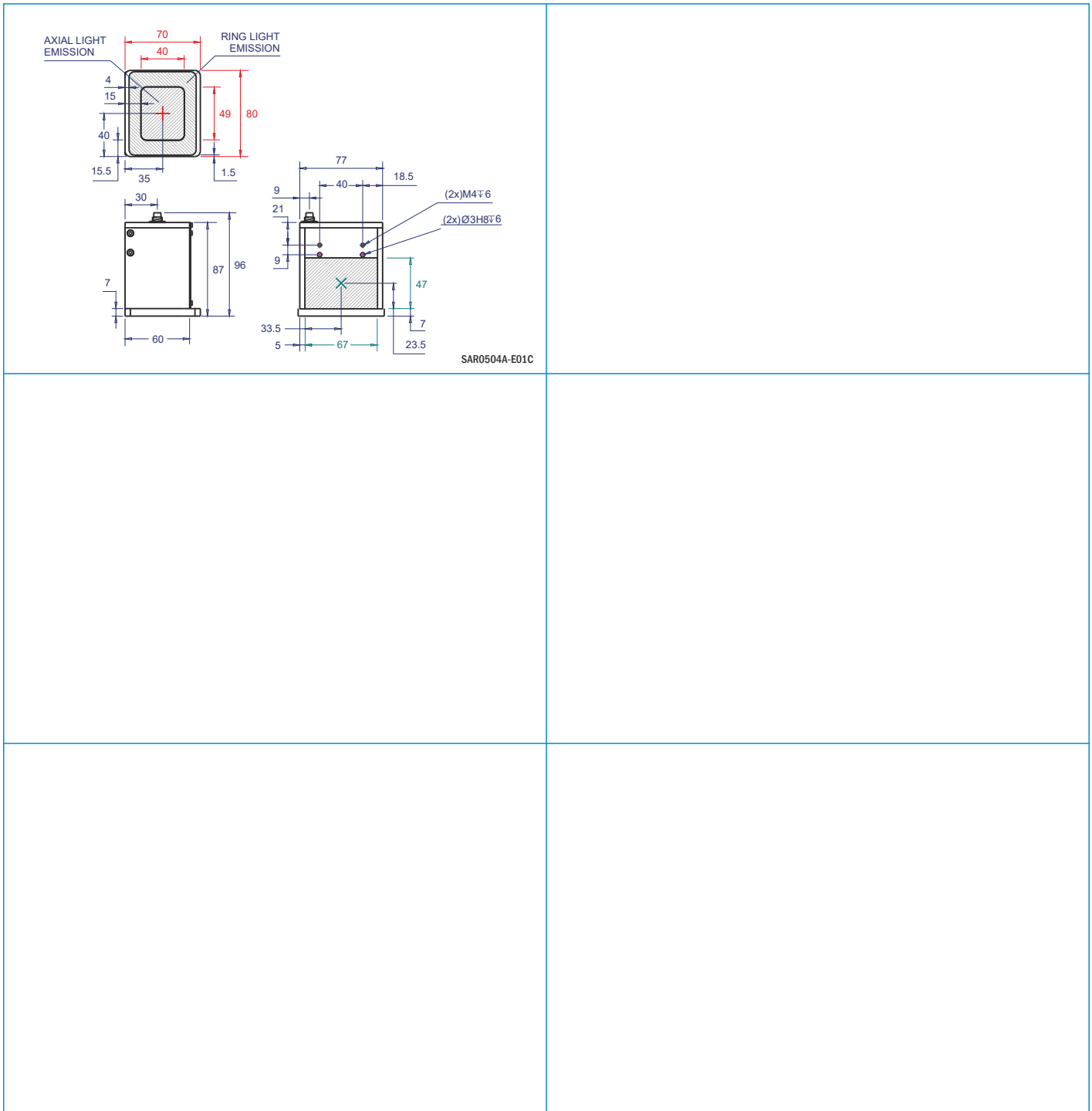

All units in millimeters, if not indicated.



Example of SAR captured image

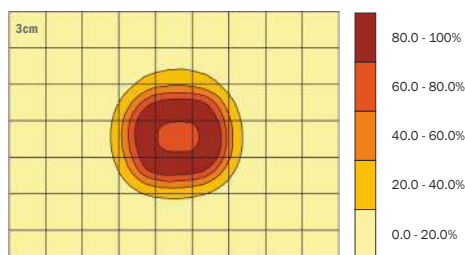

Brightness distribution of SAR0504A-630C@15mm

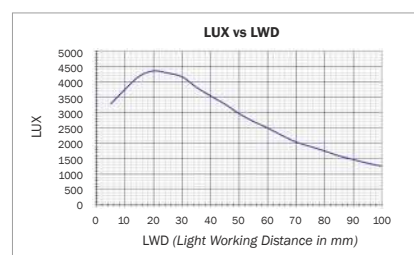

SAR0504A-630C light intensity.

SAX SERIES

















Diffuse axial lights

Diffused axial lighting system that produces a diffused light upcoming from the camera axis which eliminates shines and shadows on reflecting objects.

► Technical specifications¹

Lighting model	SAX0505A	SAX1010B	SAX1515A	SAX2020A	SAX2515A
					
Dimensions	100x62x75	150x112x140	200x162x200	250x212x270	200x262x200
Active surface	52x50	102x100	152x150	201x200	152x250
RWD (mm)	<100	<120	<180	<200	<200
Weight	480g	1530g	3125g	5570g	5715g
IP rating	IP40	IP40	IP40	IP40	IP40
Mounting holes	(x4)M4I6	(x4)M4I6	(x9)M4I6	(x9)M4I6	(x9)M4I6
Connection (Type C/S)	2P male chassis connector PIN 1 = +24V ±3% PIN 2 = 0V	2P male chassis connector PIN 1 = +24V ±3% PIN 2 = 0V	2P male chassis connector PIN 1 = +24V ±3% PIN 2 = 0V	2P male chassis connector PIN 1 = +24V ±3% PIN 2 = 0V	2P male chassis connector PIN 1 = +24V ±3% PIN 2 = 0V
Power cable (Not-included)	VCB Series	VCB Series	VCB Series	VCB Series	VCB Series
Modifiers²					
Accessories³					
iBlueDrive tech.	Built-in	Built-in	Built-in	Built-in	Built-in
iBlueDrive connection	3P male chassis connector PIN 1 = +24V ±8% PIN 2 = 0V PIN 3 = Control ⁴	3P male chassis connector PIN 1 = +24V ±8% PIN 2 = 0V PIN 3 = Control ⁴	3P male chassis connector PIN 1 = +24V ±8% PIN 2 = 0V PIN 3 = Control ⁴	3P male chassis connector PIN 1 = +24V ±8% PIN 2 = 0V PIN 3 = Control ⁴	3P male chassis connector PIN 1 = +24V ±8% PIN 2 = 0V PIN 3 = Control ⁴
iBlueDrive power cable (Not-included)	VCC Series	VCC Series	VCC Series	VCC Series	VCC Series
iBlueDrive accessories³					

► Instantaneous consumption⁵ (max.)

Lighting model	SAX0505A	SAX1010B	SAX1515A	SAX2020A	SAX2515A	*WT				
TYPE C 24VDC		4.7W	14W	26W	46W	53W	-470C			
		4.7W	14W	26W	46W	53W	-525C			
		3W	10W	21W	42W	38W	-630C			
		3W	10W	21W	42W	38W	-850C			
		4.7W	14W	26W	46W	53W	-W00C			
TYPE P	No "Type P" standard LED lighting systems in this series									
TYPE S D _{max} = 1/2 ₀ Ton max = 2ms		705mA/17W	2110mA/51W	4310mA/103W	7655mA/184W	8800mA/211W	-470S			
		705mA/17W	2110mA/51W	4310mA/103W	7655mA/184W	8800mA/211W	-525S			
		705mA/17W	2110mA/51W	4310mA/103W	7655mA/184W	8800mA/211W	-630S			
		1045mA/25W	3345mA/80W	7315mA/176W	14630mA/315W	13165mA/316W	-850S			
		705mA/17W	2110mA/51W	4310mA/103W	7655mA/184W	8800mA/211W	-W00S			
	900mA/22W channel					3600mA/86W channel	4500mA/108W channel	9600mA/230W channel	9600mA/230W channel	-RGBS
TYPE i⁶ 		3.9W[20W/3W]	11W[48W/8W]	36W[96W/24W]	26W[96W/17W]	36W[96W/24W]	-470i			
		6.2W[20W/4.3W]	18W[48W/12W]	36W[96W/24W]	26W[96W/17W]	36W[96W/24W]	-525i			
		6.2W[20W/4.3W]	18W[48W/12W]	36W[96W/24W]	26W[96W/17W]	36W[96W/24W]	-630i			
		7.7W[24W/4.1W]	24W[48W/12W]	26W[96W/17W]	26W[96W/17W]	26W[96W/17W]	-850i			
		6.2W[20W/4.3W]	18W[48W/12W]	36W[96W/24W]	26W[96W/17W]	36W[96W/24W]	-W00i			

(1) Environmental specifications and iconography legend in additional annex Z1.4 and Z2 respectively.

(2) Prior to manufacturing optional modifications in standard lighting systems. Please, consult the code before ordering (additional annex Z2.1).

(3) Accessories are not-included. More information in accessories section.

(4) iBlueDrive control input wiring specifications in additional annex Z1.2.

(5) Bear in mind that consumption table is only to be used as a guide. To refer to real values, please, consult product label when purchasing.

(6) Values of maximum instantaneous consumption of "Type i" lighting systems in **Powered mode (Strobe mode / Continuous mode)**



SAX SERIES

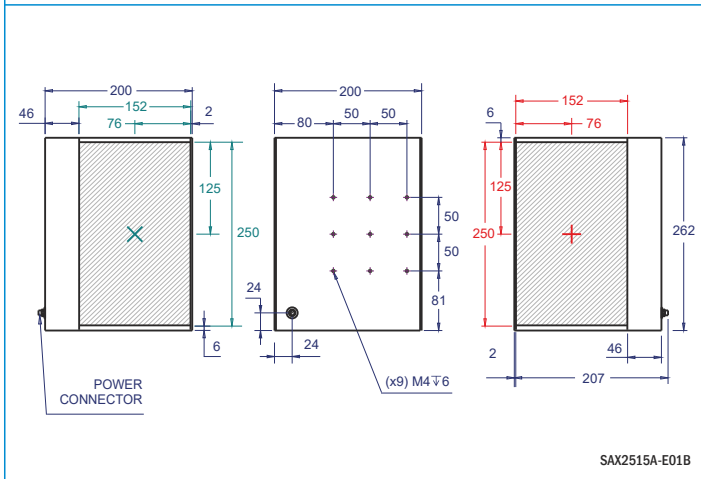
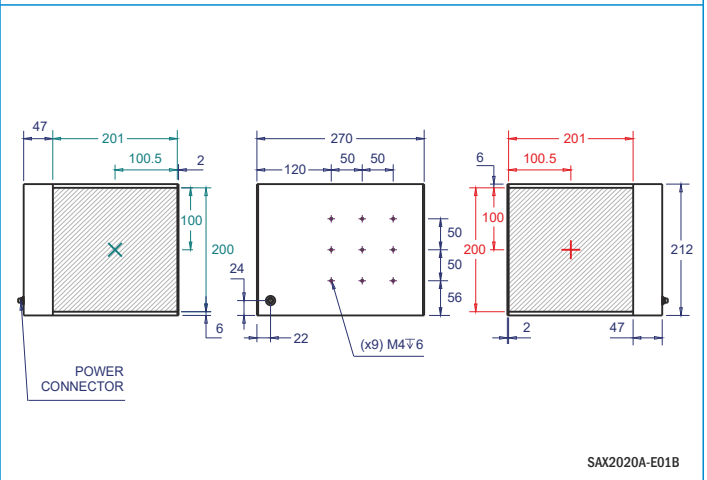
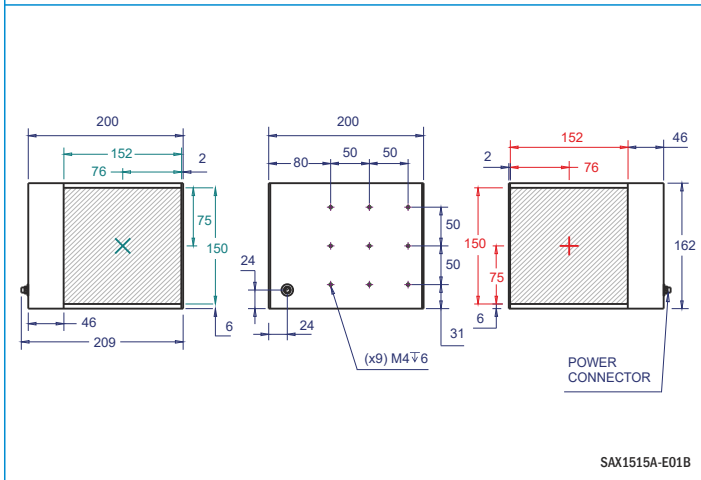
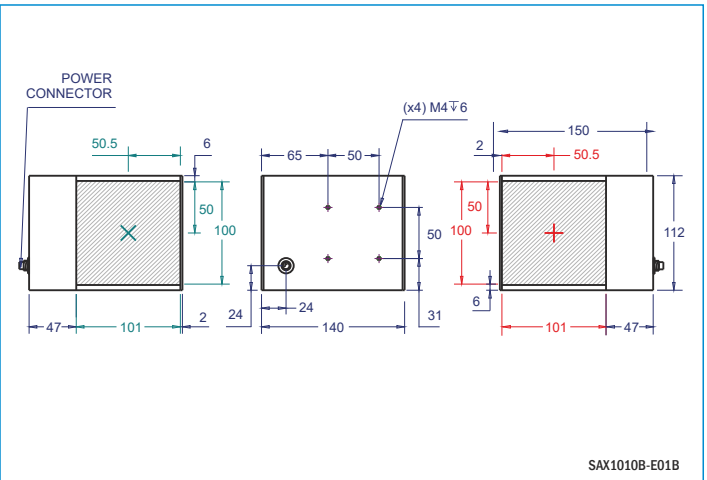
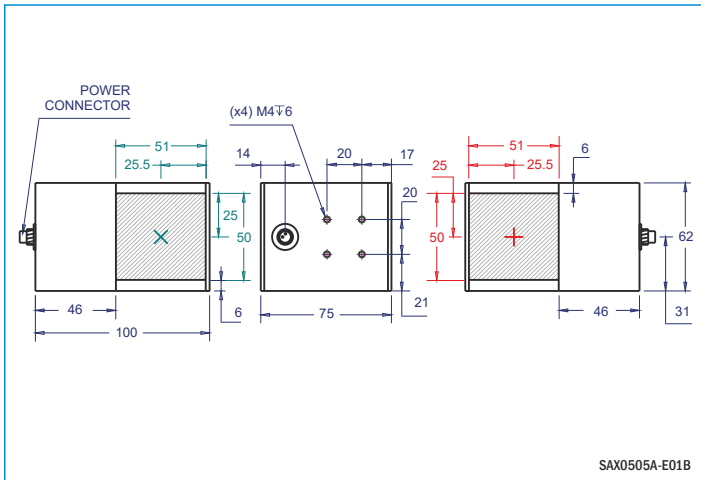

All units in millimeters, if not indicated.

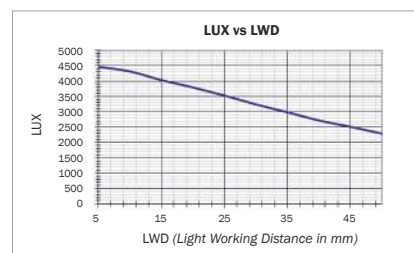
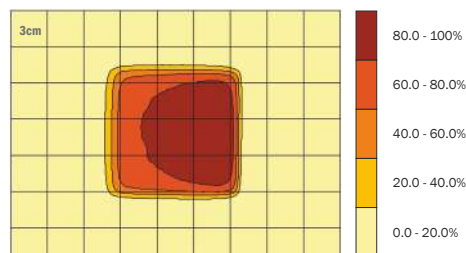

ACCESSORIES



ACCESSORIES



- ▶ LIGHTING FILTERS
- ▶ DARKFIELD CONVERTER
- ▶ HEAT DISSIPATOR
- ▶ CABLES
- ▶ FIXING BRACKETS
- ▶ ACCESORIES FOR FILTERS & CAMERAS
- ▶ COLOR TEST LAMP
- ▶ STROBE AND RGB CONTROLLERS
- ▶ IBLUEDRIVE TECHNOLOGY

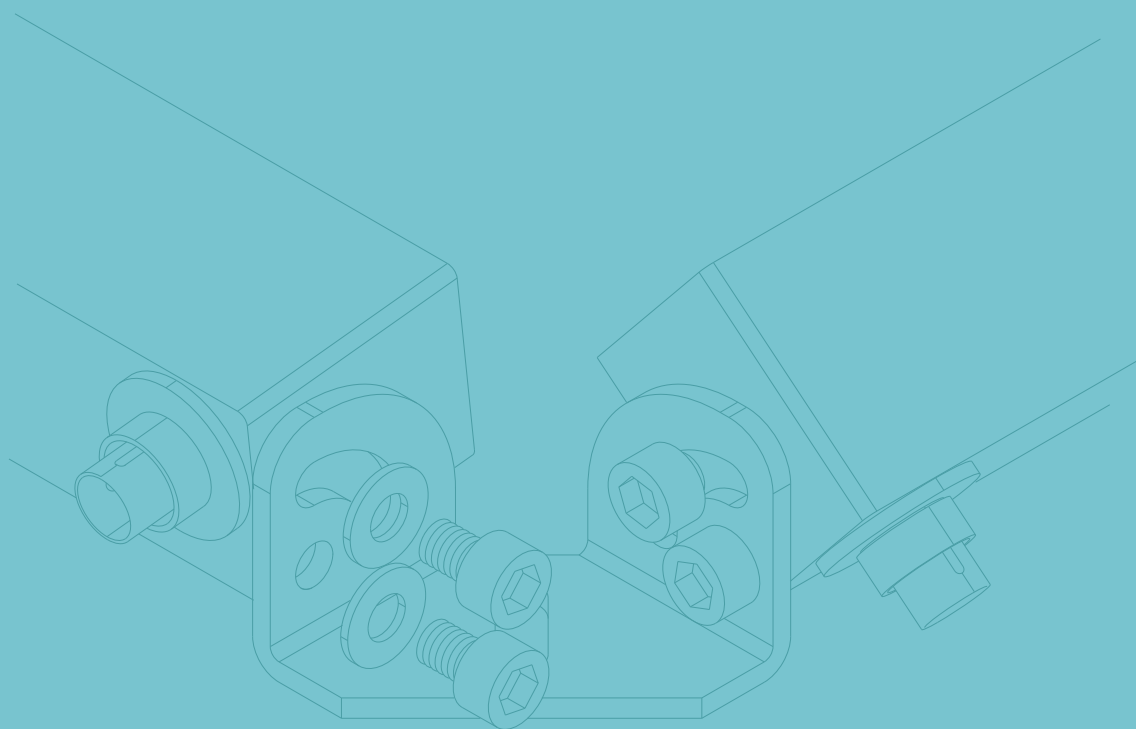

Accessories overview

DCM Sistemas offers a wide range of accessories for illumination applications and specifically for its lighting systems. These accessories are not included in the product acquisition, and some of them are necessary for the correct operation of the lamps. Assure you have all material required before starting to use DCM Sistemas products, and ask for those you would need.











Filtering

Filters can be used with the lighting system to select how the light is reaching the lens, thus broadening the range of possible lighting solutions.

In a vision application, there will often be times when using standard illumination products cannot quite achieve the desired results. In these situations, there are a number of filters and other accessories that allow the user to meet certain requirements.

Accessory type	Description
Lighting filters	Accessories that allow the user to 'fine-tune' the lighting to meet certain requirements.
Darkfield converter	To turn ringlights into darkfields through reflection
Heat dissipator	Protect from over-temperatures.
Power cables	Cables for powering DCM Sistemas lighting systems.
Interconnection cable strobe controller	Cables for interconnection of VSC Strobe controllers.
Programming cables	Cables for programming and configuring VSC Strobe controllers.
Interconnection cables	Cables for interconnecting different items.
Fixing brackets	Brackets that maintain fixed the lighting system to a specific surface.
Lense filter holders	Holder that maintain fixed the filters to specific cameras.
Protection filter for cameras	Protection filters por specific cameras.
Color test lamp	Multispectral laboratory device that allows you to check which wavelength is the most suitable one for your vision application.
Strobe and RGB controllers	Essential lighting driver for working with lights that not work in continuous mode.
iBlueDrive	Special accessories for iBlueDrive technology devices.

VCF, VDF, VPC, VPF, VPT series - Lighting filters

Filter type	Icon	Description	Series
 Collimator		Obtain a parallel shaft that forces the matching up of the lens optical axis with the central beam of the system. Available on X, Y and XY axis. Collimator filters on X axis (horizontal axis) make the light parallel on x axis, which improves the inspection of vertical edges. Instead, collimator filters on Y axis (vertical axis) make the light parallel on y axis, which improves the inspection of horizontal edges. X and Y axis are identify on backlight diagrams with the symbol: 	VCFx VCFy VCFxy
 Diffuser		Convert the emitted light from direct to diffuse light, increasing by means of this filter the aperture angle and softening the light.	VDF
 Antiglare filter		This filter is specially designed for the ALB0804A. It allows the system to eliminate specular surfaces and obtain very good quality images.	VPC
 Polarizer		Facilitate the light polarization, through which undesirable brightness are avoided by only making way for those vibrations that occur in a determinate plane.	VPF
 Protector		Preserve from dust and external conditions those lighting systems that have some fragile components.	VPT

Order reference: *(example)*

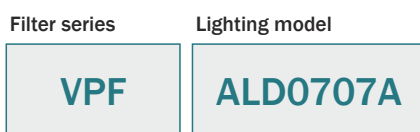

Composed by two parts. The first one is the filter, and the second is the lighting model.
Consult which lighting models can add supplementary filters at additional annex, Z4.1. or in each product datasheet.

► VPP series - Dust protection kit

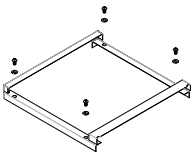
Icon	Description	Series
 <p>Dust protection kit</p>	<p>Dust protection kit for SAC and SAX series</p> <p><i>*It is necessary to have the VPT filter to order this dust protection</i></p>	VPP

Model	Ref. ACCESSORY (supplementary to the lighting system)	COMPATIBLE MODELS
Dust protection kit for VPTSAC0505A and VPTSAX0505A.	VPP0505A	SAC0505A and SAX0505A
Dust protection kit for VPTSAC0808A.	VPP0808A	SAC0808A
Dust protection kit for VPTSAC1010A and VPTSAX1010B.	VPP1010A	SAC1010A and SAX1010B
Dust protection kit for VPTSAX1515A.	VPP1515A	SAX1515A
Dust protection kit for VPTSAX2020A.	VPP2020A	SAX2020A
Dust protection kit for VPTSAC3010A.	VPP3010A	SAC3010A

Order reference: **Dust protection kit for SAC and SAX series** + **Lighting model** = **Lighting model**
(example)

VPP

+

SAC0505A

=

VPP0505A

Composed by two parts. The first one is the dust protection kit and the second is the lighting model (for SAC and SAX series).

It is necessary to have the VPT filter to order this dust protection kit. They must be ordered as an accessory (VPP + Model), as it is shown in the table below:

► VRF series - Darkfield converter

Icon	Description	Series
 <p>Darkfield converter</p>	<p>Mechanic systems that allow us to turn ringlights into darkfields through reflection. They are fitted together in the lower part of the ringlight, making the light coming into contact directly with the reflector and bouncing with a little angle. VRF reflectors permit us the creation of smaller darkfields with a big inspection area in relation with its size.</p>	VRF

► VHD series - Heat dissipator

Icon	Description	Series
 <p>Dissipator</p>	<p>Protect our lighting systems from over-temperatures. (Only for PLA Series)</p>	VHD

Order reference: **Darkfield converter or heat dissipator series** + **Lighting model**
(example)

VRF

+

ALD0707A

Composed by two parts. The first one is the darkfield converter or heat dissipator series (previous tables) and the second is the lighting model.

Consult which lighting models can add supplementary darkfield converter or heat dissipator at additional annex, Z4.1. or in each product datasheet.



Power cables

DCM Sistemas provides supplementary cables for guaranteeing the correct supply of its led lighting systems. These cables are necessary for connecting DCM Sistemas lamps, so we strongly recommend you to assure you have the specific cable required for each lighting product' connection.



VC Series

Cable series	Series	Poles	Description	Ø section	Length	Connector type	PIN colour	Connection specs.
	VCB	2	Monochromatic lighting systems without control signal.	2 x 0.5mm ²	Various Lengths available (A1.1)	<ul style="list-style-type: none"> Normal Right angle (A1.2)	PIN 1 BN/RD PIN 2 BU/BK	According to the operating mode (Consult on each product datasheet or A1.3)
	VCC	3	Monochromatic lamps with control signal or bichromatic systems.	2 x 0.5mm ² 1 x 0.2mm ²	Various Lengths available (A1.1)	<ul style="list-style-type: none"> Normal Right angle (A1.2)	PIN 1 RD PIN 2 BU/BK PIN 3 GN	According to the operating mode (Consult on each product datasheet or A1.3)
	VCD	4	Trichromatic lighting systems (RGB).	4 x 0.22mm ²	Various Lengths available (A1.1)	<ul style="list-style-type: none"> Normal (A1.2)	PIN 1 YE PIN 2 RD PIN 3 GN PIN 4 BU	According to the operating mode (Consult on each product datasheet or A1.3)

Cable's order reference:

Composed by two or three parts according to connector type. Only add the third when ordering a right angle connector. Normal connector no needs the additional part.

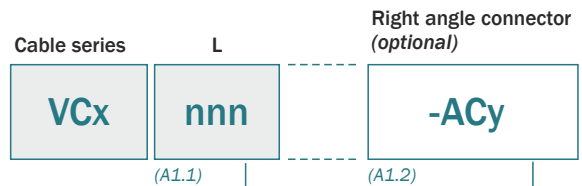

A1.1 - Power cables Length

L	Length (meters)
018	1.8
030	3
050	5
100	10
nn0	custom (nn = cable meters)

Example: VCBO18

A1.2 - Power cables connector types

Normal connector diagram

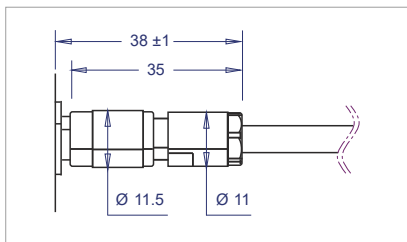

Right angle connector diagram (2 options)

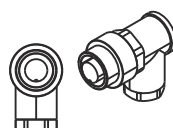
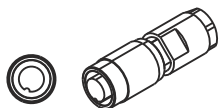
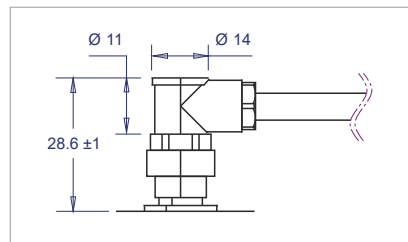

For more information about the right angle connectors please contact with DCM Sistemas.

► **A1.3 - Power cable connection specifications**

According to the operation mode (more information at introduction, page 08), connection of DCM Sistemas lamps follows the specifications below.

Series	PIN	PIN Colour	Continuous operating mode (C)	Powered operating mode (P)	Strobe operating mode (S)	iBlueDrive operating mode (I)	Pinout diagram
VCB	PIN1	BN/RD	+VDC	+VDC	OUT (+)	-	
	PIN2	BU/BK	GND	GND	OUT (-)	-	
VCC	PIN1	RD	+VDC	+VDC	OUT (+)	+VCD	
	PIN2	BU/BK	GND 1 (-)	GND 1 (-)	OUT 1 (-)	GND	
	PIN3	GN	GND 2 (-) <i>(bychromatic lamps)</i> CONTROL <i>(monochromatic with control)</i>	GND 2 (-) <i>(bychromatic lamps)</i> CONTROL <i>(monochromatic with control)</i>	OUT 2 (-) <i>(bychromatic lamps)</i> N/A <i>(monochromatic with control)</i>	CONTROL	
VCD	PIN1	YE	+VDC	+VDC	OUT (+)	-	
	PIN2	RD	GND 1 (R-)	GND 1 (R-)	OUT 1 (R-)	-	
	PIN3	GN	GND 2 (-)	GND 2 (-)	OUT 2 (-)	-	
	PIN4	BU	CONTROL	CONTROL	N/A	-	



Other cables

Apart from power cables for guaranteeing the correct supply of our lamps, DCM Sistemas provides other cables for programming or interconnecting DCM Sistemas lighting systems.



► **VCL series - Interconnection cables strobe controllers**

	Order ref.	Description	Length
	VCL10n* <i>(*n = Number of strobe controllers you want to interconnect)</i>	Interconnection of VSC series strobe controllers, thus allowing control of several lighting systems simultaneously.	According to the number of strobe controllers to interconnect.

► **VCP series - Programming cables**

	Order ref.	Description	Length
	VCP100	Essential tool for configuring VSC series strobe controllers. Compatible with USB port 1.1 or superior. USB 'A' connector.	1.8m

VCU Power cables

VCU series are thought to facilitate the connexions between applications by directly connecting between DCM Sistemas products and connecting with other brands. These cables simplify connection schemes and avoid the excess of cables in the applications.



VCU series - Interconnection cables

	Model	Description	Length
	VCU01A	Interconnection between PLD or PLU series, in case we need more than one PLD or PLU lighting system for an application, avoiding this way uncomfortable wiring from them to the power supply source.	Various Lengths available (A1.4)
	VCU02A	It is a special cable that allows us to connect systems with 3 pin connector to 2 pin connector. This connection allows forcing the continuous mode for iBlueDrive systems or for systems with control terminal without the need of an extra wiring.	Various Lengths available (A1.4)
	VCU03A	It is a converter cable from VCC 3 pin to VCB 2 pin connector. It is designed for linking led lighting systems with 2 pins in applications with DCM systems with 3 pin connector. Thus, in case you need to change the lighting system in an application, it is not necessary to change all the wiring.	Various Lengths available (A1.4)
	VCU04A	Cable M12 male to VCB 2 pin connector. With this cable we can connect DCM systems with 2 pins in applications where M12 connections are used. For example, we can connect DCM systems directly to COGNEX cameras that have external light control connection, such as the In-Sight 7000 and the DataMan 300 allowing us to power the light in continuous mode directly from the camera.	Various Lengths available (A1.4)
	VCU05A	Cable M12 male to VCC 3 pin connector. With this cable we can directly connect 3 pin DCM lighting systems in applications where M12 connection is used. For example, we can link DCM systems directly to COGNEX cameras with external light control connection, such as the In-Sight 7000 and the DataMan 300 allowing us to power the light and control it directly from the camera software.	Various Lengths available (A1.4)
	VCU06A VCB connector VCU07A VCC connector	Y Splitter cordset that allows to power two lights from just one cable. On one side it has an aerial male connector and on the other side two aerial female connectors connected in parallel. This is very useful in installations where there is only one cable installed and we have two DCM Sistemas systems.	Various Lengths available (A1.4)
	VCU08A VCB connector VCU09A VCC connector	Y Splitter cordset that allows to power three lights from just one cable. On one side it has an aerial male connector and on the other side three aerial female connectors connected in parallel. This is very useful in installations where there is only one cable installed and we have three DCM Sistemas systems.	Various Lengths available (A1.4)
	VCU10A VCB connector VCU11A VCC connector	Y Splitter cordset that allows to power four lights from just one cable. On one side it has an aerial male connector and on the other side four aerial female connectors connected in parallel. This is very useful in installations where there is only one cable installed and we have four DCM Sistemas systems.	Various Lengths available (A1.4)
	VCU12A VCB connector VCU13A VCC connector	Y Splitter cordset that allows to power five lights from just one cable. On one side it has an aerial male connector and on the other side five aerial female connectors connected in parallel. This is very useful in installations where there is only one cable installed and we have five DCM Sistemas systems.	Various Lengths available (A1.4)

Cable's order reference:

Composed by two parts according to connector type.
First one is the cable and the second one is for the length.

A1.4 - Power cables Length

L	Length (cm)
003	30
005	50
010	100
015	150
0nn	custom (nn = cable cm)



Example: VCU01A003



Fixing brackets

Brackets that maintain fixed the lighting system to specific surface.

- **VBA Series:** Lighting systems brackets
- **VBB Series:** Multifunctional brackets
- **VBC Series:** Camera brackets
- **VBD Series:** Lens Filter Holder for cameras.



► VBA Series

	Description	Order ref.	3D Fixing diagram	Diagram
	Fixing bracket for PRC0606B	VBA000A		
	Fixing bracket for PLC, PLD, PLU, PRC0604C, PRC0608C and PRD0500B to Cognex InSight 5000 camera	VBA003A		
	Fixing bracket for PLC, PLD, PLU, PRC0604C, PRC0608C and PRD0500B to Cognex InSight 7000 camera	VBA005A		
	Fixing bracket for PLA0513A and PLA1013A to Cognex InSight 7000 camera	VBA006A		

► **VBA Series**

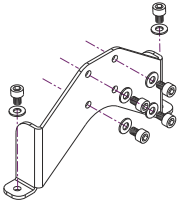
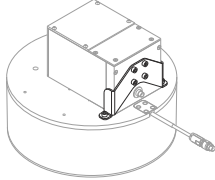
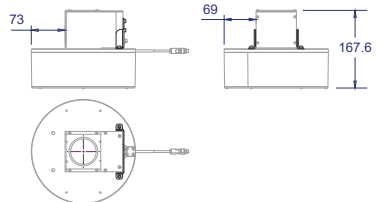
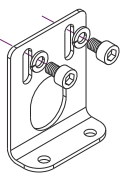
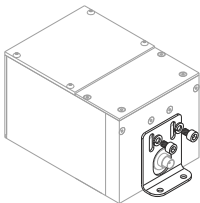
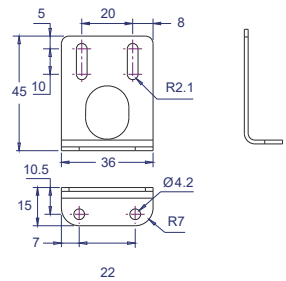
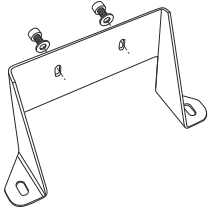
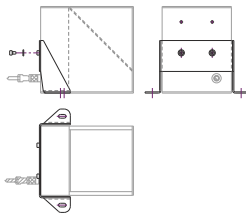
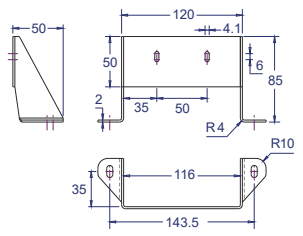
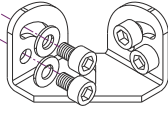
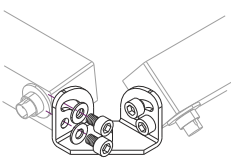
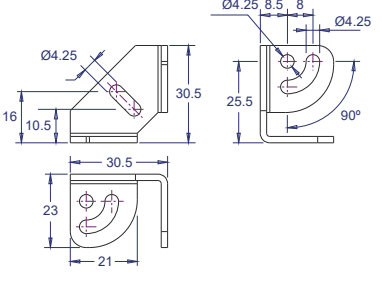
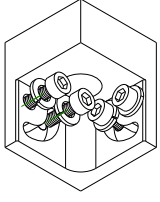
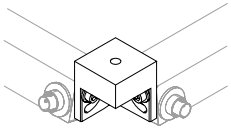
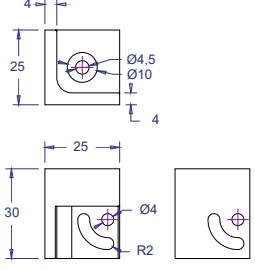
	Description	Order ref.	3D Fixing diagram	Diagram
	<p>Bracket for fixing SAC0808A to DTL3521B. (order separately)</p>	<p>VBA015A</p>		
	<p>Fixing bracket for SAX1010B</p>	<p>VBA020A</p>		
	<p>Fixing bracket for PLD/PLU to PLD/PLU Series at 90°</p>	<p>VBA030A</p>		
	<p>Fixing bracket for PLD/PLU to PLD/PLU Series at 90°</p>	<p>VBA045A</p>		
	<p>Fixing bracket for PLD/PLU to PLD/PLU Series at 90°</p>	<p>VBA045B</p>		

► **VBA Series**

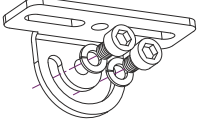
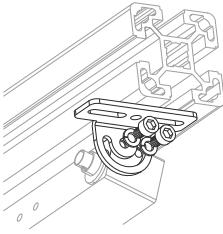
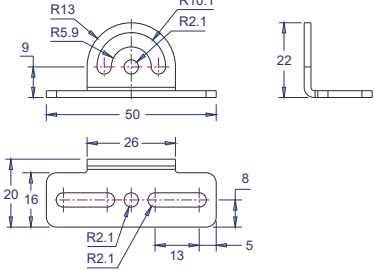
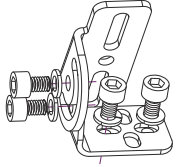
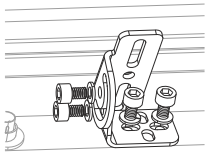
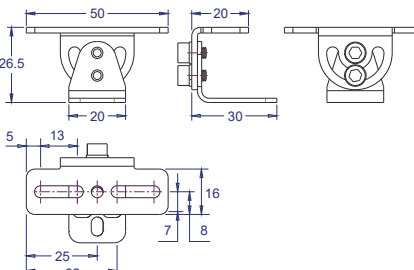
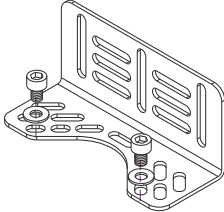
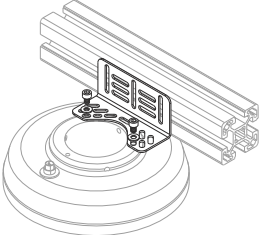
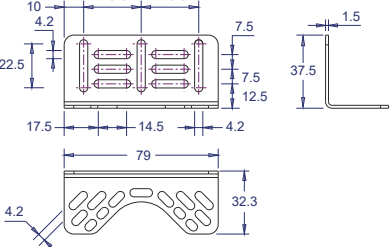
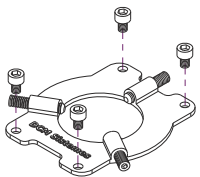
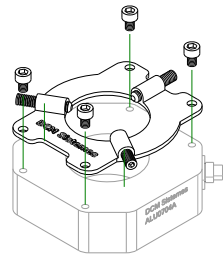
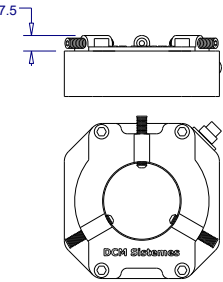
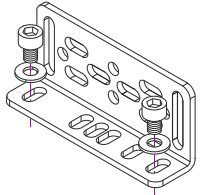
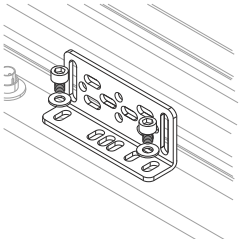
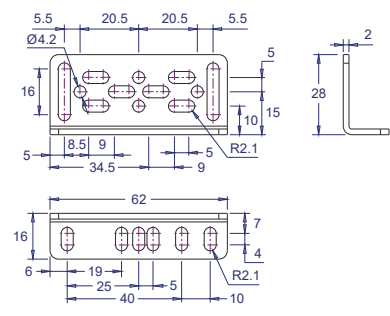
	Description	Order ref.	3D Fixing diagram	Diagram
	<p>Lateral fixing bracket for PLD, PLU, PRC0604C, PRC0608C and PRH.</p>	<p>VBA050A</p>		
	<p>Back fixing bracket for PLC, PLD, PLU, PRC0604C, PRC0608C, PRD0500B, PRH and PRL.</p>	<p>VBA055A</p>		
	<p>Fixing bracket for ALB, ALD, ALS and ALU.</p>	<p>VBA060A</p>		
	<p>Fixing bracket for ALU0704A.</p>	<p>VBA062A</p>		
	<p>Fixing bracket for BKL and BKM.</p>	<p>VBA075A</p>		

► **VBA Series**

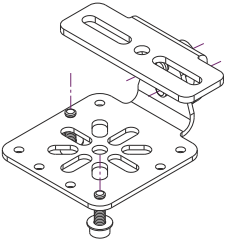
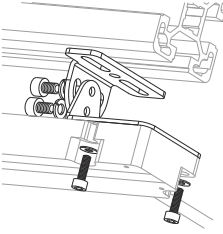
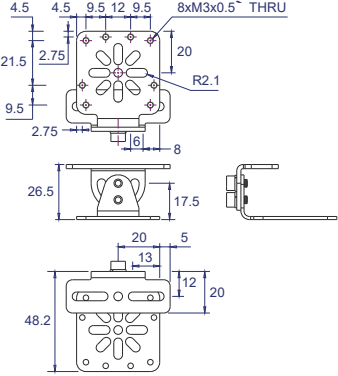
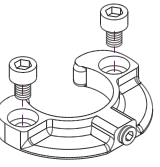
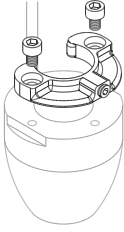
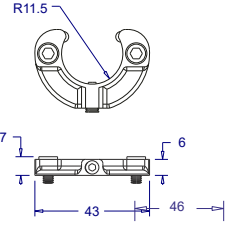
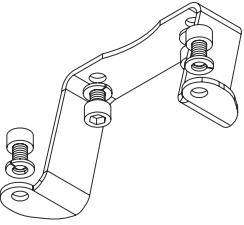
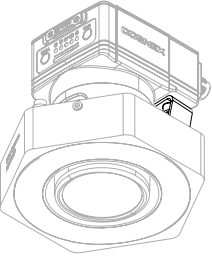
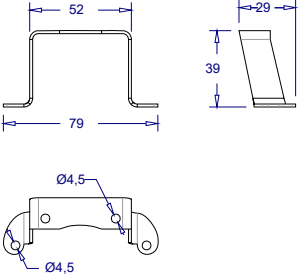
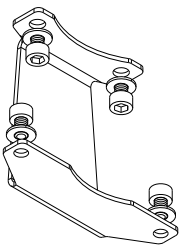
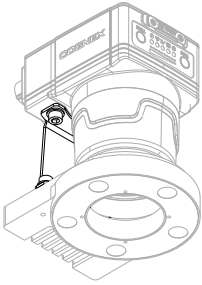
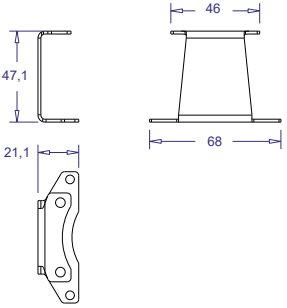
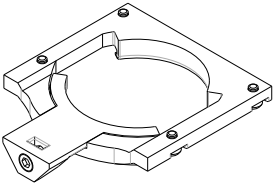
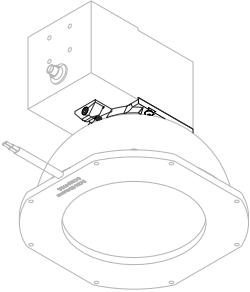
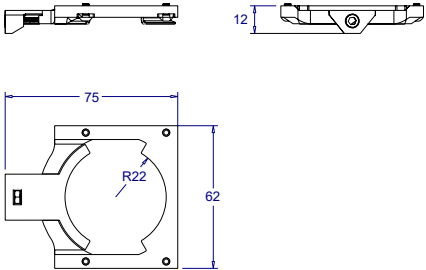
	Description	Order ref.	3D Fixing diagram	Diagram
	<p>Fixing bracket for PLA.</p>	<p>VBA090A</p>		
	<p>Fixing bracket for AUB0402A.</p>	<p>VBA100A</p>		
	<p>Bracket for fixing ALU1006A to Cognex IS7800 camera</p>	<p>VBA110A</p>		
	<p>Bracket for fixing ALB0804A and ALB0810A to Cognex IS7800 camera</p>	<p>VBA120A</p>		
	<p>Fixing bracket for SAC0505 and DOM1410.</p>	<p>VBA140A</p>		

► VBB Series

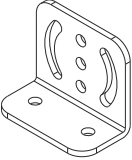
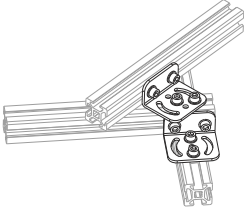
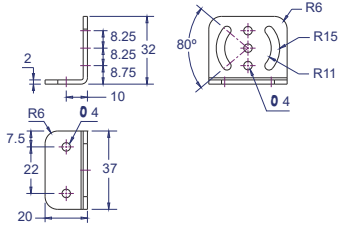
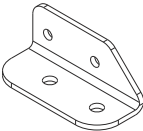
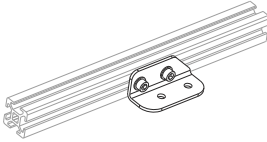
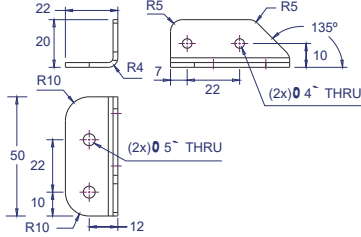
	Description	Order ref.	3D Fixing diagram	Diagram
	Multifunctional bracket	VBB000A		
	Multifunctional bracket	VBB015A		

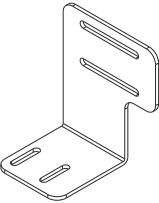
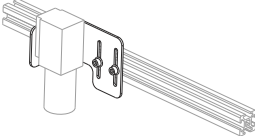
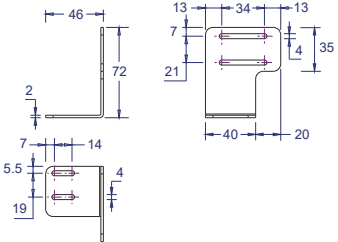

► VBC Series

	Description	Order ref.	3D Fixing diagram	Diagram
	Fixing bracket for cameras	VBC000A		

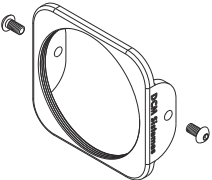
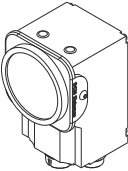
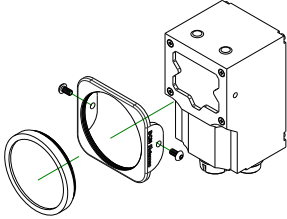
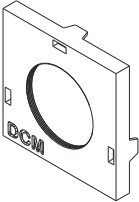
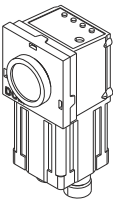
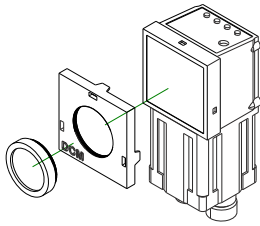
► VBD Series - Lens filter holders

	Description	Order ref.	3D diagram	3D Fixing diagram
	Lens filter holder for Keyence SR-1000 camera.	VBD010A		
	Lens filter holder for Omron FQ_CR camera.	VBD020A		

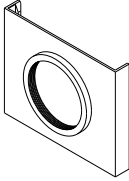
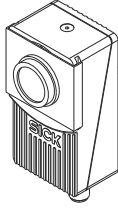
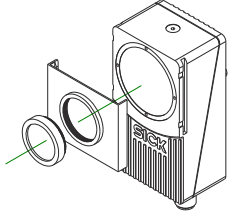
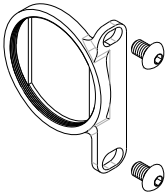
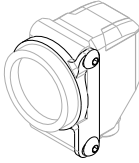
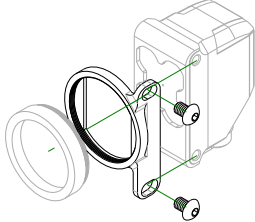
► VBD Series - Lens filter holders

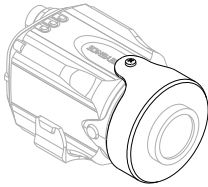
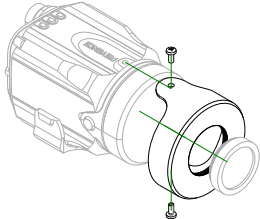
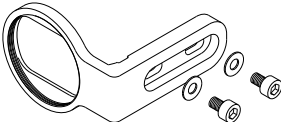
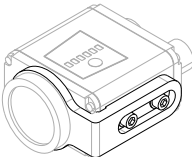
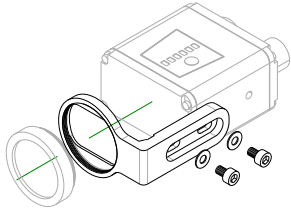
	Description	Order ref.	3D diagram	3D Fixing diagram
	Lens filter holder for Sick Inspector camera.	VBD030A		
	Lens filter holder for Keyence IV-G and IV-HG cameras.	VBD040A		
	Lens filter holder for Keyence series IV cameras.	VBD060A		
	Lens filter holder for Omron MicroHAWK F430-F cameras.	VBD090A		

► VPT series - Protector filter for cameras

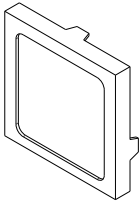
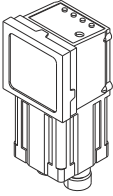
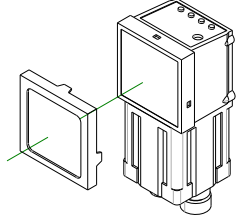
	Description	Order ref.	3D diagram	3D Fixing diagram
	Protector filter for Omron FQ_CR camera.	VPT100A		



► **VK series - Color Test Lamp**

Multispectral laboratory device that allows you to check which wavelength is the most suitable one for your vision application.

- 6 High-powered LEDs with different colors.
- Color of each LED: White, Red 630nm, Blue 470nm, Green 530nm, UV 395nm and IR 850nm.
- Battery: Li-ion. One hour ON before recharging.
- Recharges in 3 hours.
- Charger power adapter included.
- One push button testing for LEDs ON/OFF. Roll over: Red, Green, Blue, White, IR and UV.
- Auto turn OFF after 5 minutes.
- Cero power consumption in OFF mode.
- Blinking LED indicator in IR mode.
- Low battery blinking LED indicator.
- Remaining battery charge indicator when turning it OFF.

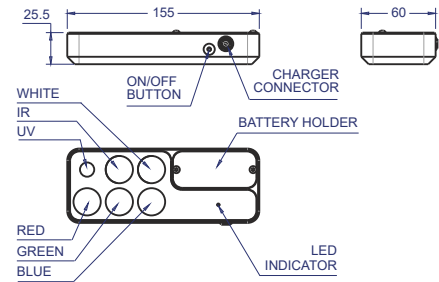

► **Order ref.: VKA0010A** (includes battery & battery charger)



Strobe and RGB controllers

A strobe controller guarantees light working conditions such as maximum consumption, maximum time ON or recovery time. Among these, the strobe controller allows to adjust the amount of light that falls into the object under inspection, and obtain static images of objects that move quickly, even when the camera has larger shutter time.



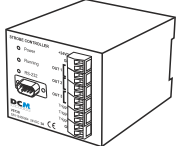

► VST Series - Strobe controllers

VST model	VST11I
	
Dimensions (mm)	90x75x103
Outputs	1
Current per output	6A max.
Inputs	1
Power supply	24VDC $\pm 3\%$
Triggers per second	Up to 2500
Input impedance	60k Ω
Pulse width	Configurable between 0 μ S...10mS in steps of 4 μ S
Pulse delay	Adjustment of initial delay
Dissipation	Low
Serial communication	PC / PLC connection
Programming	via RS-232 stored in non-volatile memory
Anchorage	35mm DIN type rail mount regulator

VST model	VST33I
	
Dimensions (mm)	90x75x103
Outputs	3
Current per output	6A max.
Inputs	3 independent. Common GND
Power supply	24VDC $\pm 3\%$
Triggers per second	Up to 2500
Input impedance	60k Ω
Pulse width	Configurable between 0 μ S...10mS in steps of 4 μ S
Pulse delay	Adjustment of initial delay
Dissipation	Low
Serial communication	PC / PLC connection
Programming	via RS-232 stored in non-volatile memory
Anchorage	35mm DIN type rail mount regulator

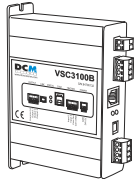
► VSC Series - RGB controllers

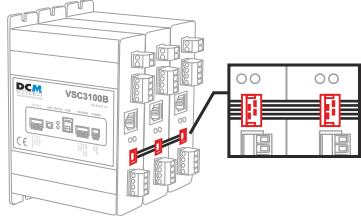
VSC model	VSC3100B
	
Dimensions	109x86x30
Description	Advanced strobe controller of three outputs for multiple lighting packages.
Channels	3
Power supply	24VDC $\pm 3\%$
Current	6A per channel. Maximum current 18A joining all outputs into one channel
Power adjust	255 levels of control at each independent exit from 0mA to the maximum level set.
Pulse width	Configurable between 24 μ S...2mS in steps of 1 μ S
Pulse delay	Between 30 μ S and 13.1mS in steps of 1 μ S
Port control	<ul style="list-style-type: none"> ■ USB programming cable VCP100 (non-included) indispensable for setting up the strobe controller. ■ RS232, RS485 or Ethernet adapter (<i>Consult</i>).
Memory bank	16 to hold preset output currents
Firmware	Updatable
Trigger input	Opto-isolated
Trigger output	For camera. Auto-trigger (enables live imaging)
Anchorage	(x2)M4 screw grooves
Control software	DCM Control Manager for Windows (free with VSC Strobe controller)  ©DCM SISTEMES PROPERTY
Scalable	Up to 24 outputs and a total of 8 devices can be controlled through one VCP100 configuration cable, by interconnecting the strobe controllers using the interface port and the VCL cable (non-included). 









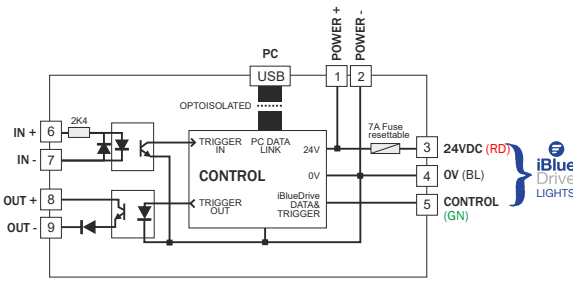

iBlueDrive accessories

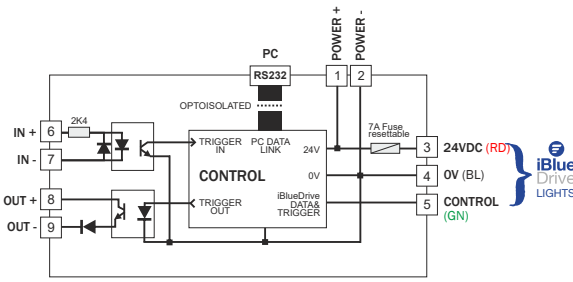
Accessories for iBlueDrive technology products

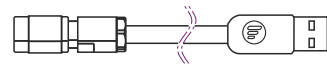

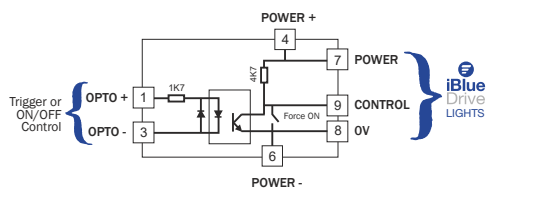
► VTA Series

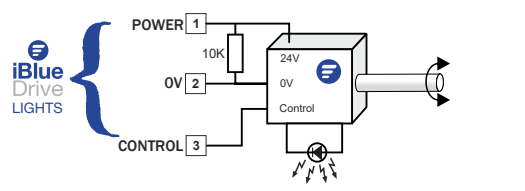
	Description	Order ref.	Simplified circuit
	<p>Adjusts and controls through the USB cable all operating parameters of iBlueDrive lighting systems, when a major control of light previous setup is needed.</p> <p>Parameters adjustment can be done 'online' or 'offline', through our free software iBlueDrive Control Manager.</p>	<p>VTA0005A</p>	
	<p>Adjusts and controls through the RS232 cable all operating parameters of iBlueDrive lighting systems, when a major control of light previous setup is needed.</p> <p>Parameters adjustment can be done 'online' or 'offline', through our free software iBlueDrive Control Manager.</p>	<p>VTA0006A</p>	
	<p>Cable USB to configure iBlueDrive devices with no external power supply needed.</p>	<p>VTA0007A</p>	
	<p>Isolates the output of lighting systems with iBlueDrive technology. It is designed to operate reliably in industrial environments.</p> <p>It is recommended to use iBlueDrive VTA0020A with iBlueDrive devices when connecting the trigger signal or controlling the light source.</p>	<p>VTA0020A</p>	
	<p>The VTA0030B Digital Potentiometer is an iBlueDrive accessory to dimmer and turn ON and OFF one or more iBlueDrive lamps in continuous mode.</p> <p>Controls and regulates the lighting intensity of iBlueDrive devices in Continuous mode, adjusting from 0% to 100% the lighting output.</p>	<p>VTA0030B</p>	

ADDITIONAL

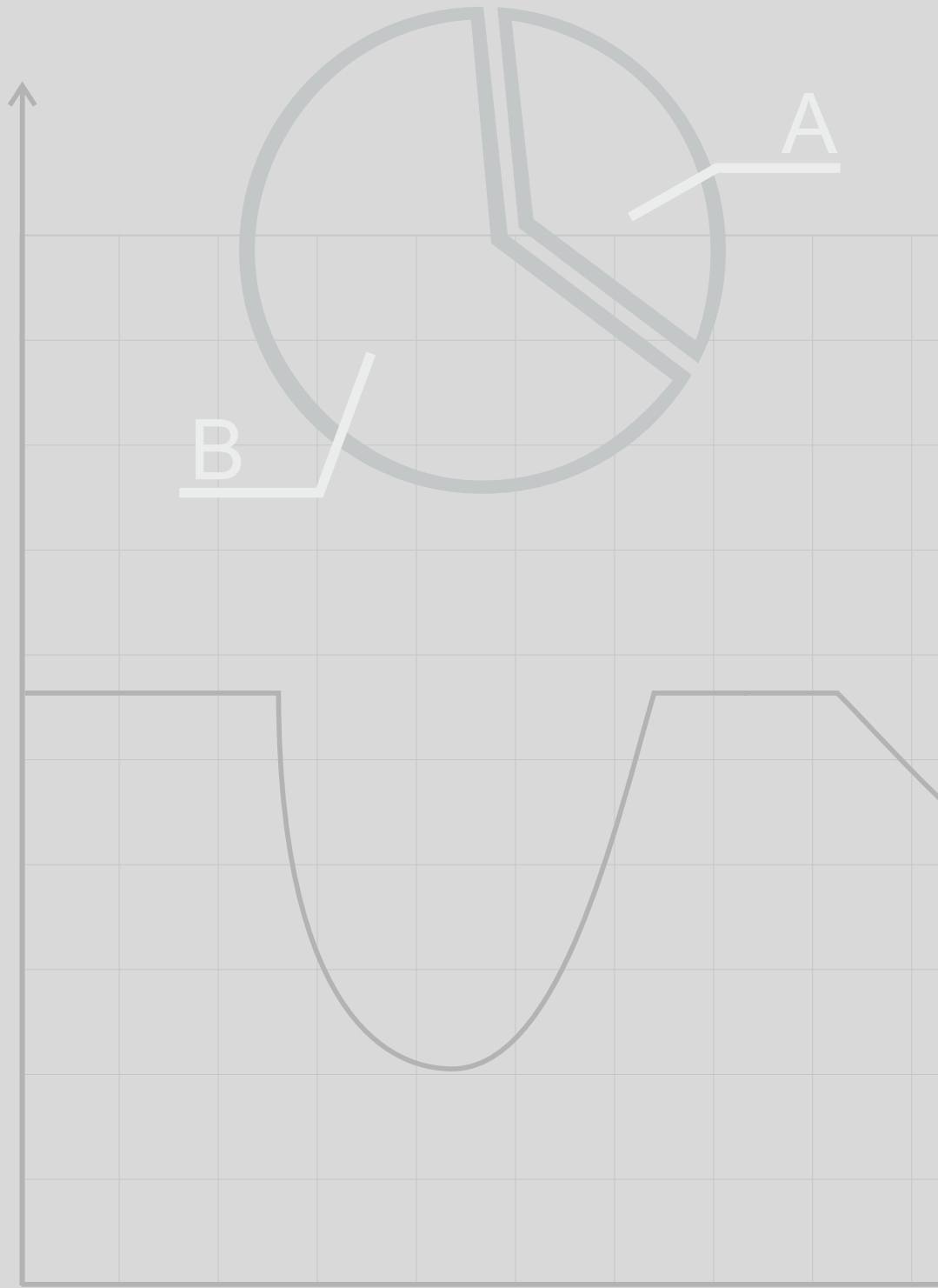

ADDITIONAL ANNEX

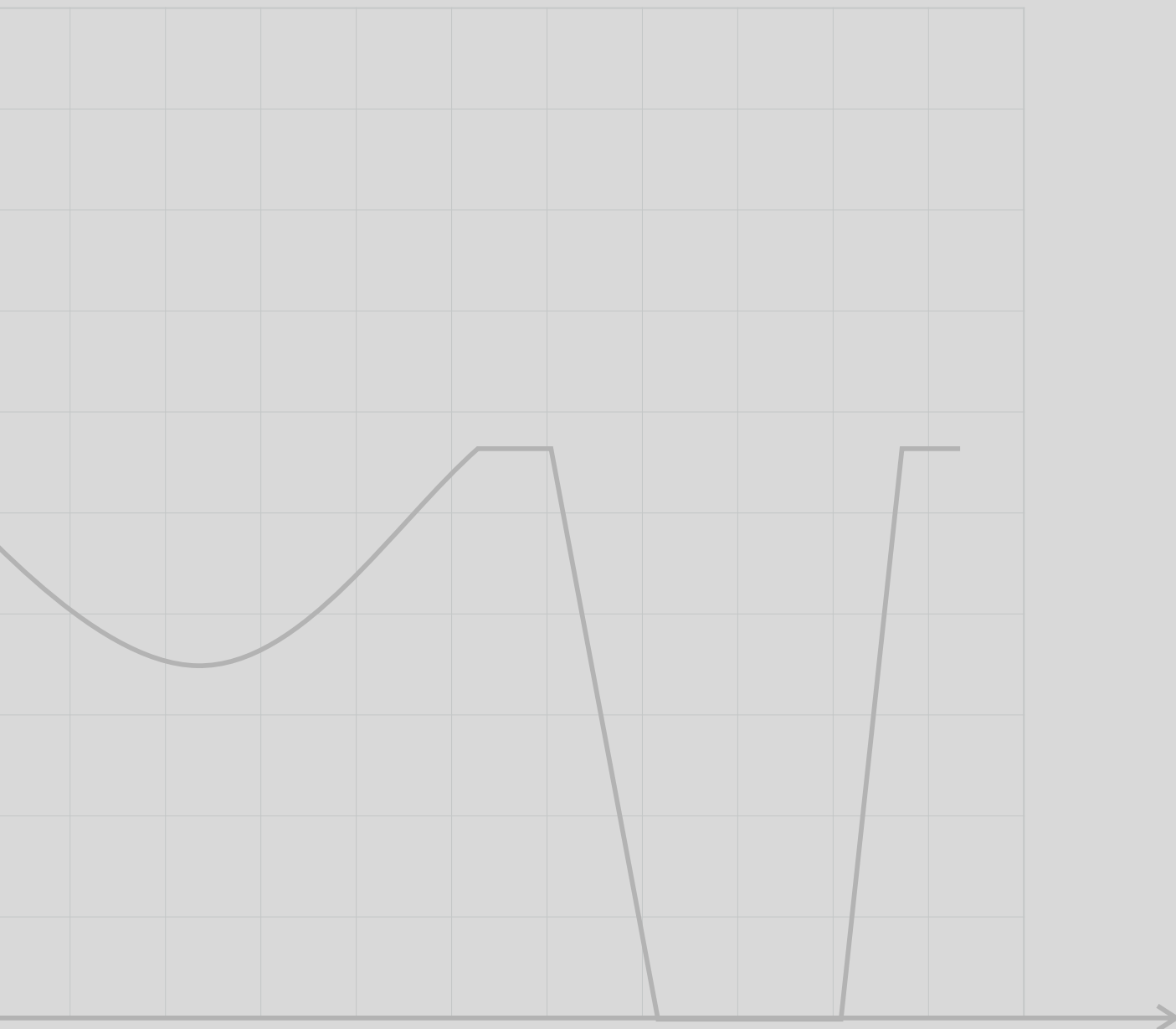



► Z1.1 - Control input NPN/PNP for 'Type C' lighting systems of DOL, PLA (PLA0513A and PLA1026A), PLC, PRC (PRC0604C and PRC0606B), PRH and PRK series.

■ NPN model (by default)

NPN chart of Vcontrol (Volts) vs Icontrol (mA)

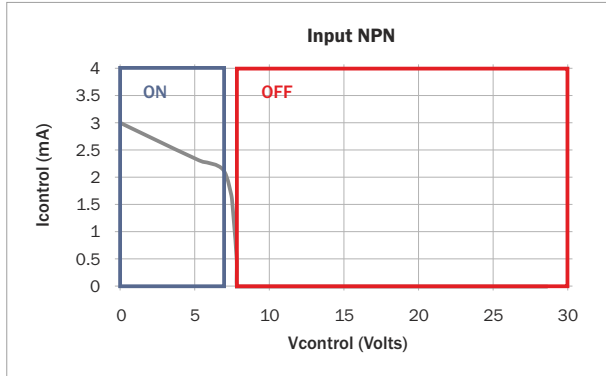

NPN wiring for ON/OFF mode

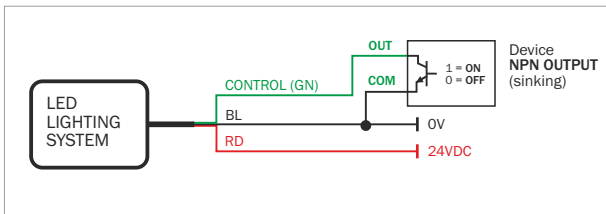

Electrical specifications

0V to +6.8V	Light ON
+7.2V to +24V	Light OFF
Working conditions	25°C, VIN = 24V
Connection	Direct to a NPN output
Delay from OFF to ON state	<5 µs
Delay from ON to OFF state	<5 µs
Bias voltage in control input	7.9V
Input impedance	7K9 Ω

■ PNP model (lighting systems with PNP modifier =/P)

PNP chart of Vcontrol (Volts) vs Icontrol (mA)

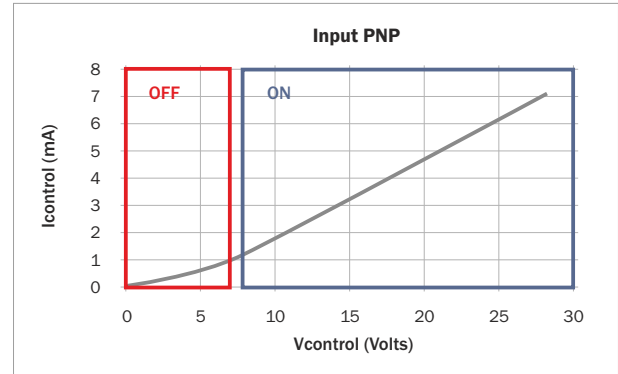

PNP wiring for ON/OFF mode

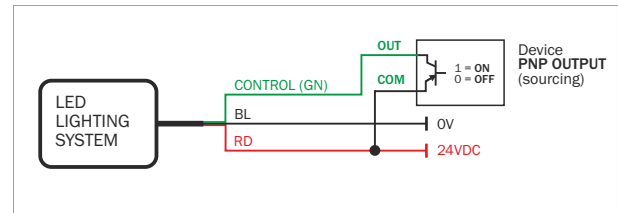

Electrical specifications

0V to +6.8V	Light OFF
+7.2V to +24V	Light ON
Working conditions	25°C, VIN = 24V
Connection	Direct to a PNP output
Delay from OFF to ON state	<5 µs
Delay from ON to OFF state	<5 µs
Bias voltage in control input	0V
Input impedance	4K Ω
Compliance	IEC1131-2 Type 1, 2 and 3



► Z2.1 - iBlueDrive control input wiring

All iBlueDrive products come together with a quick-start guide for connection and working conditions. Refer to iBlueDrive Manual for extended information.

NPN wiring for strobe or ON/OFF mode

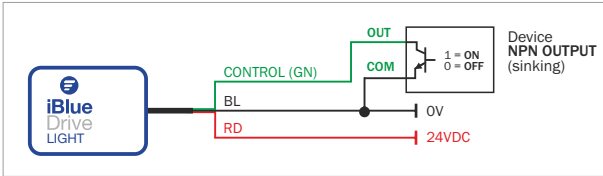

PNP wiring for strobe or ON/OFF mode

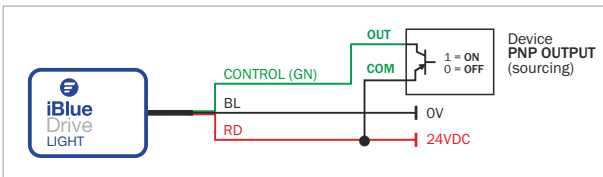

TTL wiring for strobe or ON/OFF mode

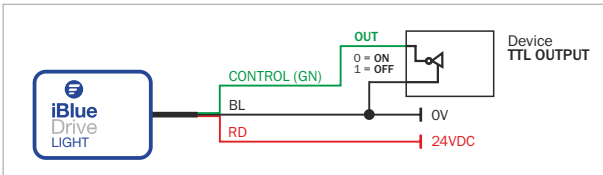

Wiring for continuous mode

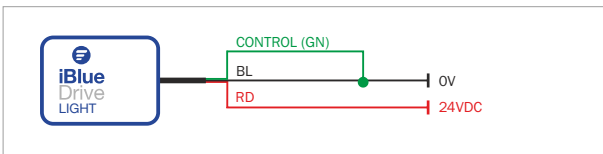

► Z2.2 - iBlueDrive inline

iBlueDrive inline is the driver for iBlueDrive technology integrated as a box of 65x33mm to the cable that goes from the lighting system to the connector. It is used when iBlueDrive driver can not be integrated on chassis. See *diagram*:

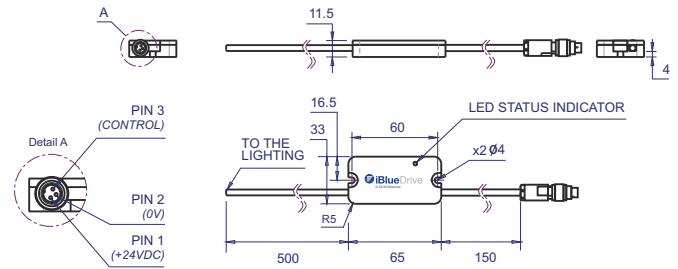



WARNING! In continuous and powered mode, clamp driver to a metal surface for heat dissipation. In Strobe mode is not required, but recommended.

► Z2.3 - iBlueDrive Accessories legend

















icon	Description	Serie/Product
	Accessorie to configure iBlueDrive devices: iBlueDrive Box, iBlueDrive USB	VTA0005A, VTA0006A, VTA0007A
	iBlueDrive optocoupler	VTA0020A
	iBlueDrive potentiometer	VTA0030B















► Z3.1 - Environmental Specifications

Max. Operating Humidity	85% non-condensing
Operating Temperature	0 - 40°C
Storage Temperature	0 - 60°C
Housing material	Anodized aluminium
Standards	  





► Z3.2 - Modifiers legend

icon	Description	Code
	Narrow angle of emission	/AN
	Medium angle of emission (default)	/AM
	Wide angle of emission	/AW
	Oval angle of emission = 23-24° (x) 17-18° (y)	/AO
	Diffuse emission	/AD
	Polarizer filter	/FPL
	Diffuser filter	/FDR
	Backlight hole of 42mm	/H
	Backlight hole of 65mm	/H1
	Dome hole of 46mm	/CC1
	Dome hole of 40mm	/CC2
	IP Rating = IPxx = Ip65 / IP67	/65 / 67
	PNP input model	/P
	50mm focal Length	/F1
	150mm focal Length	/F2
	Infinite focal Length	/F3
	Lighting by sectors = 2 or 4 sectors	/2S / 4S







► Z3.3 - Accessories legend

icon	Description	Serie
	Power cable/s	VCB, VCC, VCD Series
	Other cable/s	VCU, VCL
	Strobe and RGB controller/s	VST, VSC Series
	Polarizer filter	VPF, VPC
	Diffuser filter	VDF
	Collimater filter on x axis	VCFx
	Collimater filter on y axis	VCFy
	Collimater filter on xy axis	VCFxy
	Darkfield converter	VRF
	Protector filter	VPT
	Heat dissipator	VHD
	Fixing bracket	VBA, VBB, VBC Series







► Z3.4 - Technical drawings legend

icon	Description
	Optical axis
	Viewing window dimensions
	Lighting elements
	Light emission center
	Lighting surface dimensions



► Z3.5 - Colours & Wavelegths legend

icon	Wavelength	Colour	Code
	365nm	UV-	-365
	400nm	UV	-400
	470nm	BLUE	-470
	525nm	GREEN	-525
	630nm	RED	-630
	850nm/880nm	IR	-850/-880
		WHITE	-W00
		RGB	-RGB

► Z3.6 - Types of lighting legend

icon	Description
	Radial lighting
	'Darkfield' lighting effect. Low angle illumination
	Backlight illumination
	'Cloudy day' lighting effect
	'Bright field' lighting effect
	Projector lighting
	Axial lighting

► Z3.7 - Types of light legend

icon	Description
	Direct light
	Diffuse light
	Ultra-diffuse light



► Z4.1 - Choosing the correct illumination for your application

Using the right illumination saves costs in processing images. There are many ways to choose the right illumination with proper size, colour, intensity, among others. There are some considerations to take into account before choosing.

Summarizing, the key to perfect inspection:
Do everything to make your camera image as good as possible (high contrasts, stability, uniformity...), create independence from disruptive ambient light, choose the right illumination option with proper size, colour, intensity, etc. Not all surface effects can be predicted and simulated. Ask our technical engineers at DCM Sistemas.

1
PURPOSE & APPLICATION

Purpose of illumination

Image processing applications can be for visual inspection, character recognition, measuring dimensions and/or positioning. We must decide between homogenous illumination of the entire (interesting) field of view, generation of high contrast between object features and surroundings or an individual intensive light source that provides independence from disruptive ambient light, among other specific characteristics.

2
WORKPIECE UNDER INSPECTION

Defect characteristics

These defects will influence on illumination techniques and working distances.

Coloured objects

Coloured object features appear brighter if the light is the same colour and object appears darker if the light colour is complementary. Take note that short-wave light scatters more on the surface (blue or UV radiation).

- For example, we will generally use:
- Avoid reflections with shiny objects. → Homogeneous illumination technology (dome, axial, etc.)
 - Emphasize structures and embossings. → Side illumination
 - Detection of scratches, angular phases, impressions or outer contours. → Dark-field effect
 - Measurement applications or error detection with slides, glass, etc. → Backlight illumination



Colour camera & white light



Monochrome camera & white light



Monochrome camera & red light



Monochrome camera & IR light



3
ENVIRONMENT & OPERATION

Size of field of view (scene)

Influence on illumination type and size. Is it a large image area? Or a regular field of view? Is very homogenous illumination required? These questions will guide us in choosing the type of lamp, high-powered illuminators or not, etc.

Amount of light needed

Influence of coloured object, object geometry and surface, working distances, extraneous light, exposure time and conveyor belt speed will determine the quantity of light needed.

Hint, it can be used band-pass filter for suppression of disruptive extraneous light or strobe controllers for shorter shutter time which avoid motion blur.

Working distances. Ideal working distance for illumination

The further away the illumination, the less diffuse the light is because illumination is getting more and more a point light source. Light intensity diminishes quadratically with distance.

5
OTHER CONSIDERATIONS

Parameters for a correct illumination

- WaveLength (colour)
- Colour temperature ("white" light)
- Special waveLengths (IR/UV)
- Beam angle of the illumination (direct/diffuse)
- Direction of light: Above, from the side, below, from one or both sides, circular, etc.
- Special characteristics: polarised, coherent, etc.
- Mechanical details.

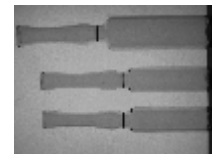

No filters

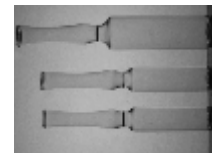

Collimator filter x axis added

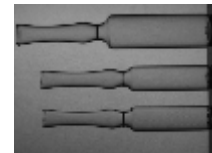

Collimator filter y axis added

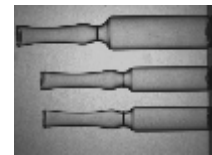

Collimator filter xy axis added

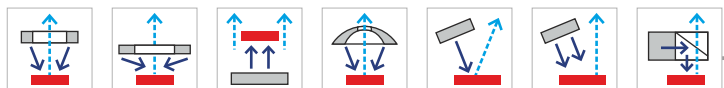

Once we have taking into account all previous considerations, we will be able to choose the suitable lighting system for the application from more than 1500 references available.



Model	iBlueDrive ¹	Cable ²	Accessories	Modifiers
DTL3521B	-	VCD	VCU VST - - - - -	- - - - -
PLA0513A	-	VCC	VCU - VPF - - VDF - - VBA006A VBA090A VHD	- - - - - /P /AN /AM /AW /AO /AD - - - -
PLA1013A	Built in	VCC	VCU - VPF - - VDF - - VBA006A VBA090A VHD	- - - - - /AN /AM /AW /AO /AD - - - -
PLA1026A	-	VCC	VCU - VPF - - VDF - - VBA090A 2-VHD	- - - - - /P /AN /AM /AW /AO /AD - - - -
PLA2026A	Built in	VCC	VCU - VPF - - VDF - - VBA090A 2-VHD	- - - - - /AN /AM /AW /AO /AD - - - -
PLC0307A	-	VCC	VCU - VPF - - VDF - - VBA090A -	- - - - - - - - - - - - - - - -
PLC0412C	Built in	VCC	VCU - VPF - - VDF - - VBA050A VBA055A -	- - - - - /67 /P /AN /AM /AW - /AD - - - -
PLC0615A	-	VCC	VCU - VPF - - VDF - - VBA050A VBA055A -	- - - - - - - - - - - - - - - -
PLC0824C	Built in	VCC	VCU - VPF - - VDF - - VBA050A VBA055A -	- - - - - /67 /P /AN /AM /AW - /AD - - - -
PLC1231A	-	VCC	VCU - VPF - - VDF - - VBA050A VBA055A -	- - - - - - - - - - - - - - - -
PLC1236C	Built in	VCC	VCU - VPF - - VDF - - VBA050A VBA055A -	- - - - - /67 /P /AN /AM /AW - /AD - - - -
PLC1648C	Built in	VCC	VCU - VPF - - VDF - - VBA050A VBA055A -	- - - - - /67 /P /AN /AM /AW - /AD - - - -
PLC2060C	Built in	VCC	VCU - VPF - - VDF - - VBA050A VBA055A -	- - - - - /67 /P /AN /AM /AW - /AD - - - -
PLD0602B	inline	VCB	VCU VST VPF - - VDF - - VBA050A VBA055A VBA045A VBA050A VBA055A -	- - - - - - - - - - - - - - - -
PLD1002A	inline	VCB	VCU VST VPF - - VDF - - VBA050A VBA045A VBA050A VBA055A -	- - - - - - - - - - - - - - - -
PLD1302B	inline	VCB	VCU VST VPF - - VDF - - VBA050A VBA045A VBA050A VBA055A -	- - - - - - - - - - - - - - - -
PLD1802A	inline	VCB	VCU VST VPF - - VDF - - VBA050A VBA045A VBA050A VBA055A -	- - - - - - - - - - - - - - - -
PLD2602A	inline	VCB	VCU VST VPF - - VDF - - VBA050A VBA045A VBA050A VBA055A -	- - - - - - - - - - - - - - - -
PLU0602B	inline	VCB	VCU VST VPF - - - - - VBA050A VBA045A VBA050A VBA055A -	- - - - - - - - - - - - - - - -
PLU1002A	inline	VCB	VCU VST VPF - - - - - VBA050A VBA045A VBA050A VBA055A -	- - - - - - - - - - - - - - - -
PLU1302B	inline	VCB	VCU VST VPF - - - - - VBA050A VBA045A VBA050A VBA055A -	- - - - - - - - - - - - - - - -
PLU1802A	inline	VCB	VCU VST VPF - - - - - VBA050A VBA045A VBA050A VBA055A -	- - - - - - - - - - - - - - - -
PLU2602A	inline	VCB	VCU VST VPF - - - - - VBA050A VBA045A VBA050A VBA055A -	- - - - - - - - - - - - - - - -
PRA0818A	inline	VCB	VCU VST - - - - - VBA050A VBA045A VBA050A VBA055A -	- - - - - - - - - - - - - - - -
PRC0604C	-	VCC	VCU - VPF - - - - - - - - -	- - - - - /67 /P /AN /AM /AW - /AD - - - -
PRC0606B	-	VCC	VCU - VPF - - VDF - - VBA050A VBA055A -	- - - - - /P /AN /AM AW - /AD - - - -
PRC0608C	Built in	VCC	VCU - VPF - - - - - VBA000A -	- - - - - /67 - /AN /AM /AW - /AD - - - -
PRD0200A	inline	-	- VST - - - - - VBA050A VBA055A -	- - - - - - - - - - - - - - - -
PRD0500B	inline	VCB	VCU VST - - - - - - - - -	/FPL /FDR - /67 - - - - - - - - - -
PRF0103A	inline	VCC	VCU - - - - - VBA055A -	- - - - - /P - - - - - - - - - -
PRH0104A	Built in	VCC	VCU - VPF - - - - - VBA055A -	- - - - - /67 /P /AN /AM /AW - /AD - - - -
PRH1612A	Built in	VCC	VCU - VPF - - - - - VBA050A VBA055A -	- - - - - /67 /P /AN /AM /AW - /AD - - - -
PRK0608A	Built in	-	- - - - - VBA050A VBA055A -	- - - - - - - /AN /AM /AW - /AD - - - -
PRLnn00B	-	-	- - - - - VBA050A VBA055A -	- - - - - /P - - - - - /AD /F1 /F2 /F3 -
PRY0504A	inline	VCB	VCU VST - - - - - VBA055A -	/FPL /FDR - - - - - - - - - -
PRY0906A	Built in	VCB	VCU VST - - - - - - - - -	- - - - - - - - - - - - - - - -
PRY1609A	Built in	VCB	VCU VST - - - - - - - - -	- - - - - - - - - - - - - - - -
SAC0505A	inline	VCB	VCU VST - - - - - VPP VPT - - - - -	/FPL - - - - - - - - - - - - - - - -
SAC0808A	Built in	VCB	VCU VST - - - - - VPP VPT - VBA020A -	/FPL - - - - - - - - - - - - - - - -
SAC1010A	Built in	VCB	VCU VST - - - - - VPP VPT - VBA015A VBA020A -	/FPL - - - - - - - - - - - - - - - -
SAC3010A	Built in	VCB	VCU VST - - - - - VPP VPT - VBA030A -	/FPL - - - - - - - - - - - - - - - -

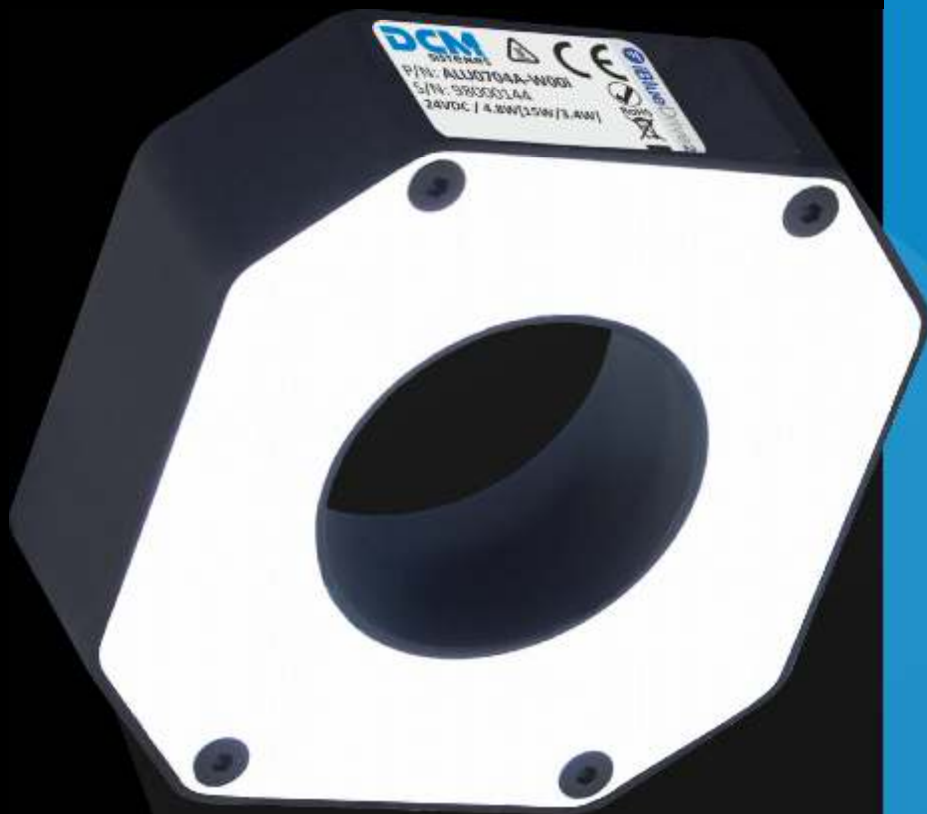

CONTACT US

Polytec France

99 rue pierre semard - Technosud II
Bâtiment A

T. +33 1 49 65 69 03
c.courtois@polytec.fr

www.polytec.com/fr/

©2021 DCM SISTEMES™. All rights reserved.
Product specifications and design are subject to
change without prior notice.

Handed over by: