

PCM

LINEAR MOTION POSITION SENSORS

Ø 35 Section, STANDARD 50-900mm

Pulling Rod Type



The sensor is built for easy mounting by double built in connectors, enable a large angle of misalignment and without back-lashes. A built-in connector system that is designed of reliability and safety contributes to excellent performance. These series can be used in a wide range of applications in mechanical and vehicle engineering industries as well as in automation and robotics technologies, combining remarkable robustness with high accuracy.

Unique Features

- Anodized aluminium housing
- Stroke lengths from 50 to 900mm
- Twin-bearing actuating rod
- Excellent linearity to $\pm 0.05\%$
- Repeatibility better than 0.01mm
- Smooth Low Noise Output from Conductive Plastic Tack
- Very Long Life
 - >100 x 10⁶ Cycles
 - >25 x 10⁶ m
- Stroke : 50-900mm
- Outstanding Linearity : $\pm 0.05\%$
- High Resolution : Infinite
- Excellent Repeatability : $\pm 0.01\text{mm}$
- Max operating speed : 5m/s max.
- C193 4-PIN Connector
- Fuse Protected optional
- Operating temperature : -30 ~100°C
- Storage Temperature : -50 ~120°C

Technical Specifications		
Sealing - PCM		IP65
Current Resistance		$\leq 10\text{mA}$
Wiper		$\leq 1\text{mA}$
Operating Force		$\leq 10\text{N}$
Power Consumption		3W-10W
Output Smoothness		$< \pm 0.1\%$ against input voltage
Input Voltage		60 V Max
Insulation Voltage		500V-1 min Residue $< 5 \mu\text{A}$
Vibration		IEC 68-2-6:1982 10g
Shock		IEC 68-2-29:1968 40g

ORDER CODE

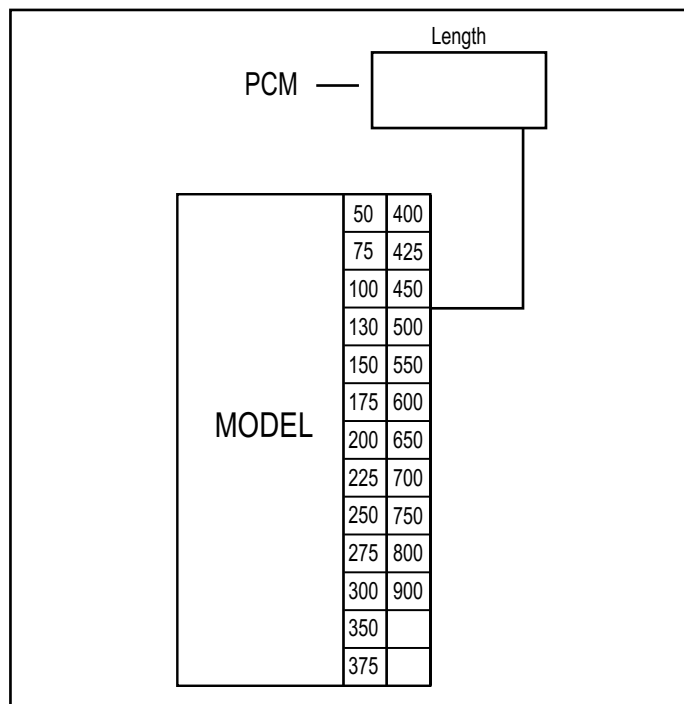

PCM

LINEAR MOTION POSITION SENSORS

Ø 35 Section, STANDARD 50-900mm

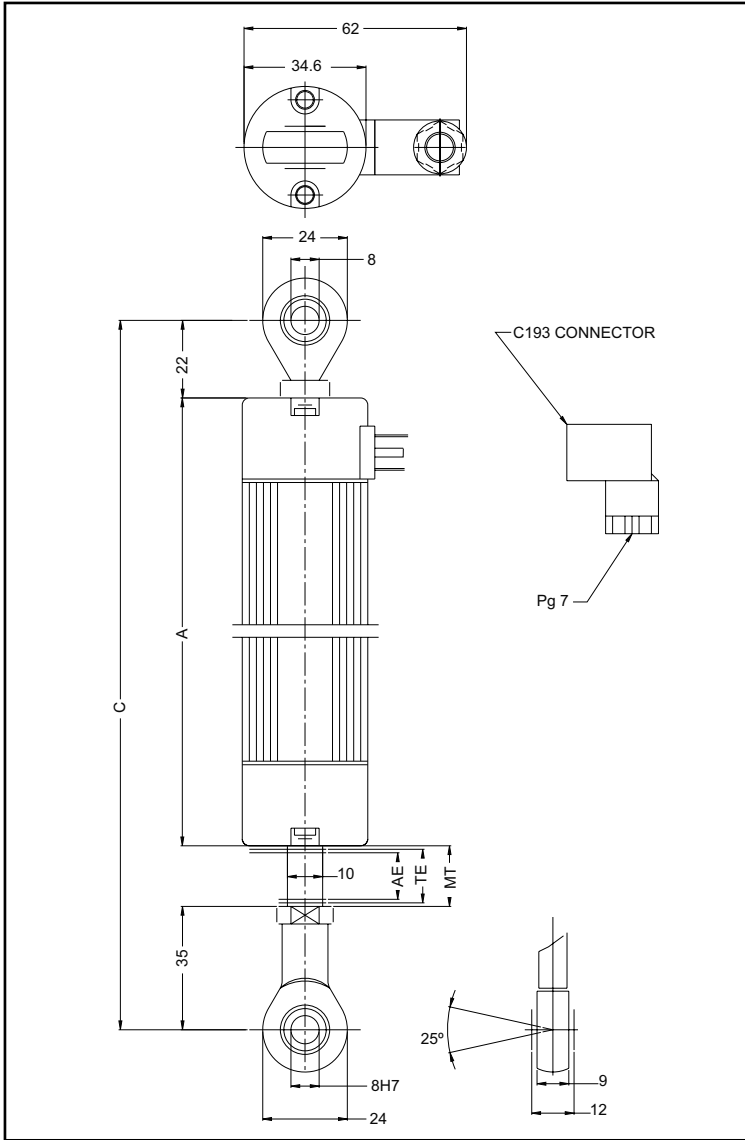

ELECTRICAL CONNECTIONS

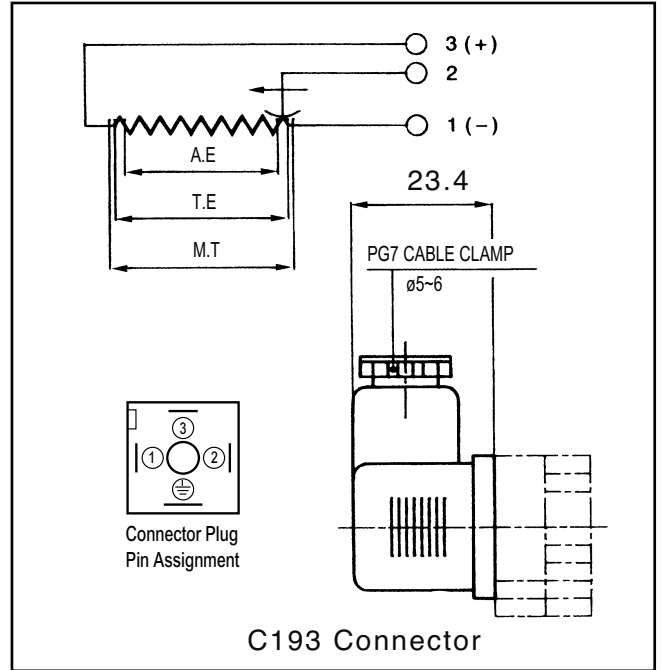

RECOMMENDED MEASUREMENT CIRCUIT

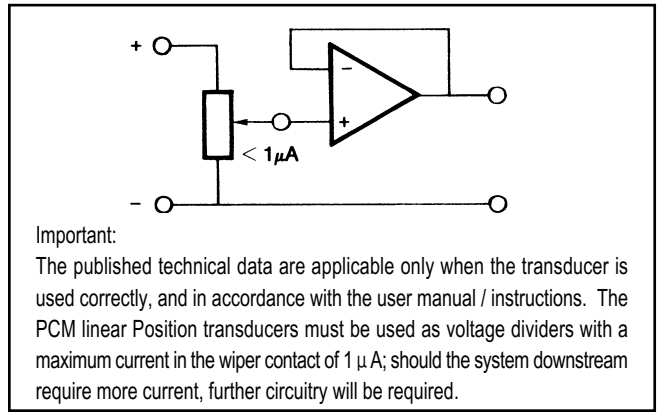

PCM series		50	75	100	130	150	175	200	225	250	275	300	350	375	400	425	450	500	550	600	650	700	750	800	900	
Total Electrical Travel (T.E)	mm	53	78	103	133	153	178	204	229	254	279	304	354	380	406	432	457	508	558	609	659	710	762	812	914	
Active Electrical Travel (A.E)	mm	51	76	101	131	151	176	202	227	252	277	302	352	378	404	430	455	506	556	607	657	708	760	810	912	
Resistance $\pm 20\%$	k Ω	5	5	5	5	5	5	5	5	5	5	5	5	5	5	5	5	5	5	5	10	10	10	10	10	
Independent Linearity	$\pm\%$	0.05	0.05	0.05	0.05	0.05	0.05	0.05	0.05	0.05	0.05	0.05	0.05	0.05	0.05	0.05	0.05	0.05	0.05	0.05	0.05	0.05	0.05	0.05	0.05	
Mechanical Travel (M.T)	mm	59	84	109	139	159	184	210	235	260	285	310	360	386	412	437	463	518	568	619	669	720	772	822	924	
Resolution		infinite																								
Recommended Cursor Current	μA	< 1																								
Temperature Range	$^{\circ}C$	-30 to +100																								
Dimensions (A)	mm	166	191	216	246	266	291	318	343	368	393	419	484	509	534	561	609	673	723	799	849	899	983	1054	1174	
Dimensions (C)	mm	223	248	273	303	323	348	375	400	425	450	476	541	566	591	618	666	730	780	856	906	956	1040	1111	1231	

* Dimensions for reference only