



FROID

## VITRINE RÉFRIGÉRÉE VM



- Vitre courbe ou droite
- Portillons coulissants plexi côté service
- Construction tout inox
- Carrosserie inox
- Tablette de travail inox
- Eclairage fluorescent intégré
- Étagère intermédiaire en verre
- Surface d'exposition inox
- Evaporateur statique
- Température +2 à +6°C (par +25°C d'ambiance)

Chariot support vendu séparément

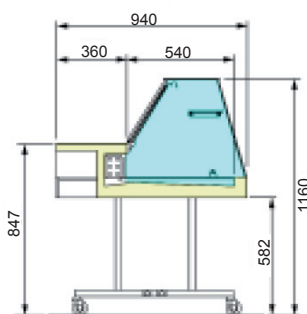

VM STD

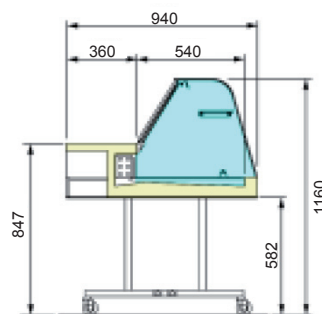

VM LX

RÉFÉRENCE		100	125	150
Dimensions ext. (l*p*h)	mm	1010*940*1150	1260*940*1150	1510*940*1150
Capacité (brut/net)	lt	217/85	276/107	336/130
Température	°C	+1 / +10 °C	+1 / +10 °C	+1 / +10 °C
Classe climatique	N°°C/RV	3/25/60%		
Alimentation	V/PH/Hz	230/1/50		
Puissance	W/A	230/2.3	280/2.4	300/2.5
Poids net	kg	88	99	102

**Sté CHRISTIAN RAGE**

Avenue de la Mer  
34470 Pérols

Tél: 0467500180 / Fax: 0467501166



E-mail: [contact@christianrage.fr](mailto:contact@christianrage.fr)

Site: [www.christianrage.fr](http://www.christianrage.fr)