



# ELECTRA™ BIN

## Operator Instruction Leaflet

IMPORTANT NOTE: ENSURE THAT ALL RELEVANT PERSONNEL READ THESE INSTRUCTIONS PRIOR TO USE

### To Open.

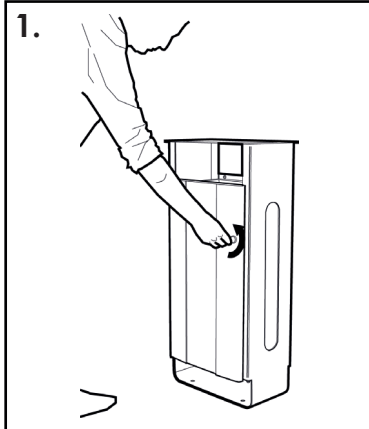

1. Using the triangular-shaped key provided, turn the key anti-clockwise to unlock the door.

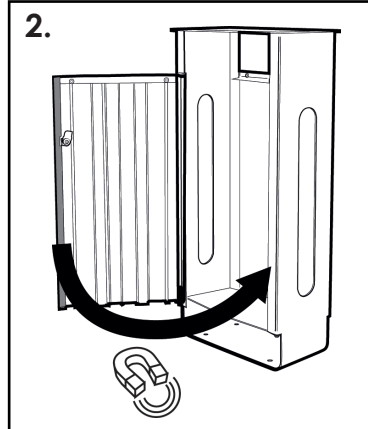

2. The door is fitted with a magnetic strip to help retain the door when unlocked.

The magnet will take a small amount of force to override. The magnet is designed to keep the door shut whilst the liner / refuse sack is emptied.

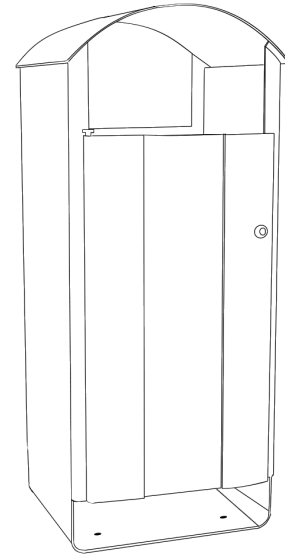

### To Empty and Replace Solid Liner.

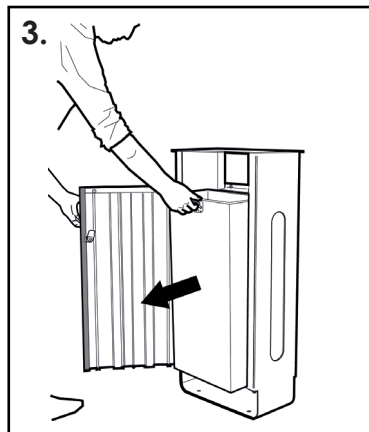

3. Slide the liner out of the bin by pulling on the liner handle.

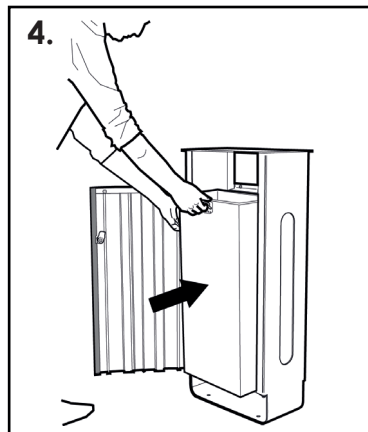

4. Lift the liner inside the bin and rest it on the internal shelf using the liner handle.

All applicable to Electra™ Curve  
Excluding 'To Empty and Replace Ashtray'.

### To Secure a Sack in Position (Sack Retention Model).

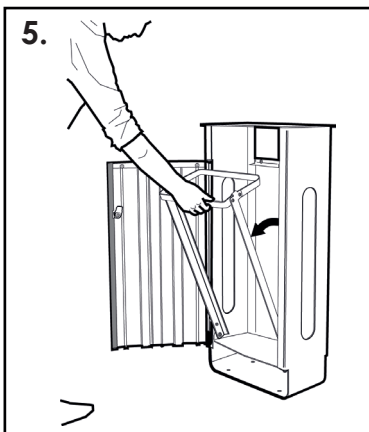

5. Pull the sack retention system forwards.

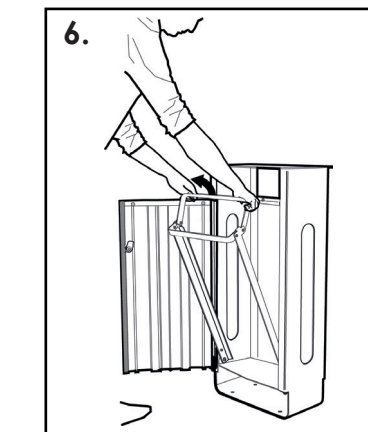

6. Pull the rear sack band upwards.

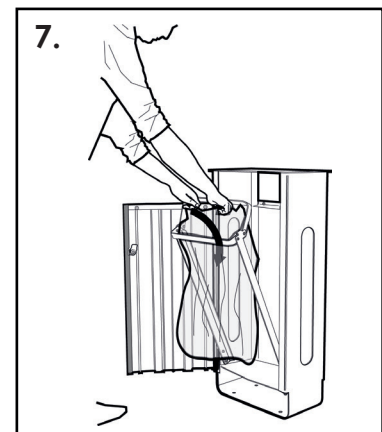

7. Drop the sack down through the sack bands.



# ELECTRA™ BIN

## Operator Instruction Leaflet

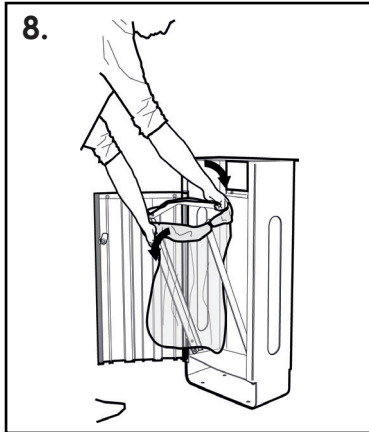

8. Press the edges of the bag over the edge of the sack bands. Press the rear sack band downwards to add tension and secure the sack in place.

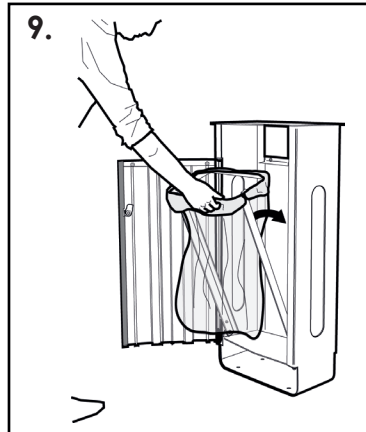

9. Push the sack retention system back inside the bin.

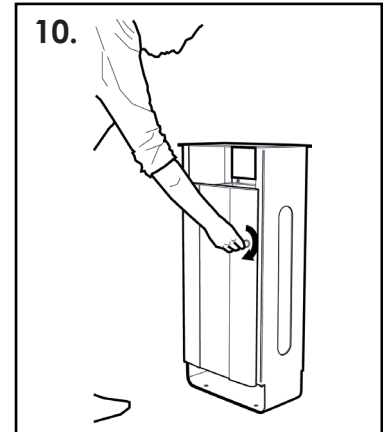

10. Close the door and lock the bin using the triangular key, turning the key clockwise.

### To Empty and Replace the Ashtray Liner. - Not Applicable for Electra Curve

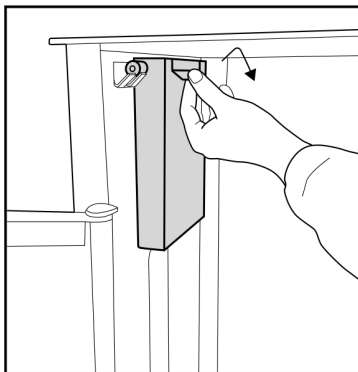

Open the bin (as shown in diagrams 1-2) and remove main bin liner or pull the sack retention forwards. Lift Ashtray from brackets and remove from the bin.

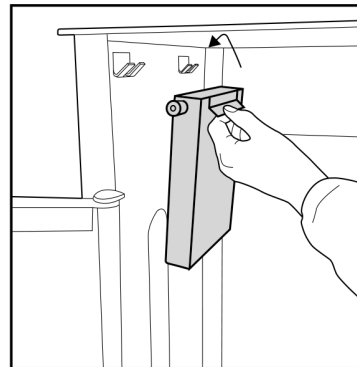

Empty Ashtray liner and replace by hooking back onto the brackets.

### To Assemble the Freestanding Base

- |  |    |
|--|----|
| <b>ITEM 1</b> - Free Standing Base Kit | x1 |
| <b>ITEM 2</b> - M10 Screw              | x4 |
| <b>ITEM 3</b> - M10 Washer             | x4 |
| <b>ITEM 4</b> - M10 Nut                | x4 |

- TOOLS REQUIRED**
- |                       |     |
|-----------------------|-----|
| 10mm Spanner / Socket | x 1 |
|-----------------------|-----|

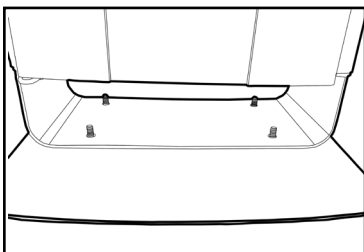

Place the Free Standing Base on the ground, with the pre-fixed screws protruding upwards.

Place the Electra Litter Bin on the Free Standing Base and align holes in the base of the bin with the four screws.

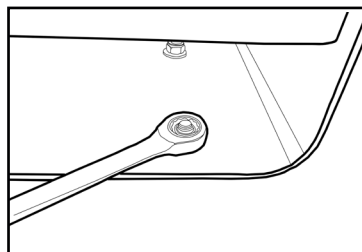

Secure in position using the M10 washer [ITEM 3] and M10 Nut [ITEM 4] and tighten using an M10 Spanner.

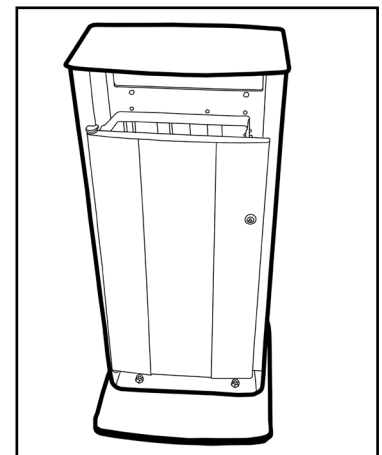

Ensure the base is secured in position and place in an appropriate location.



# ELECTRA™ BIN

## Operator Instruction Leaflet

### To Install the Litter Bin (Ground Fixing).

#### **KIT CONTENTS:**

ITEM 1 - Anchor Rawl Plug x 4

ITEM 2 - Screw (M10 x 60mm) x 4

ITEM 3 - M10 x 50mm Washer x 4

#### **TOOLS REQUIRED:**

Marker Pen

Drill with Ø16mm Masonry Drill Bit

Hammer

17mm Socket Set or 17mm Spanner

Lubricant or Grease

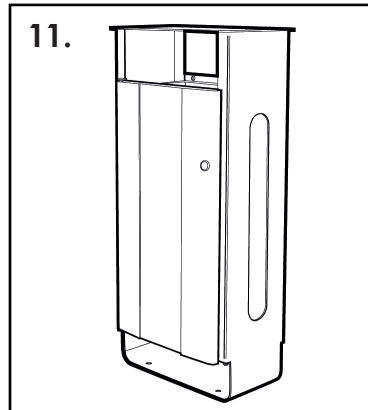

11. Place the bin in the desired location. Inspect the condition of the concrete you wish to install in to. If installing into paving slabs- ensure fixings are not positioned within 110mm of the edge of a slab (as doing so may cause the slab to break).

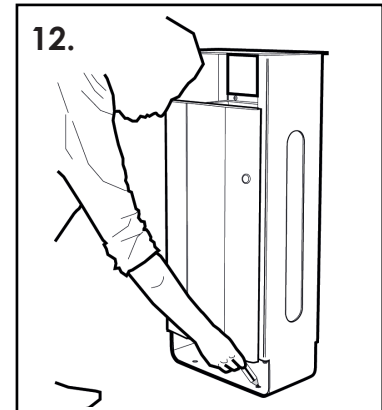

12. Mark the positions of the four ground fixing holes in the base of the bin onto the concrete base below using a marker pen.

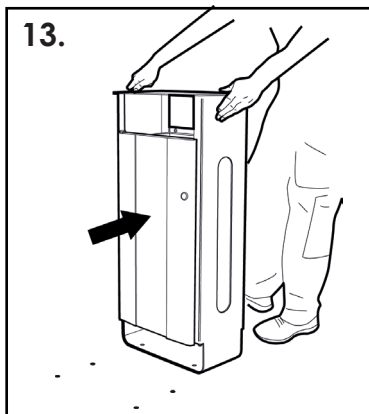

13. Move the bin to one side to allow the holes to be drilled. Ensure the holes are clearly visible.

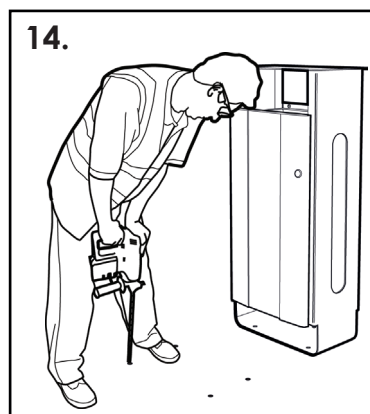

14. Using a powerful drill - drill the four 16mm diameter fixing holes to a minimum depth of 80mm. Afterwards, take care to ensure the concrete dust is removed from the holes using an air blower or sweeping brush.

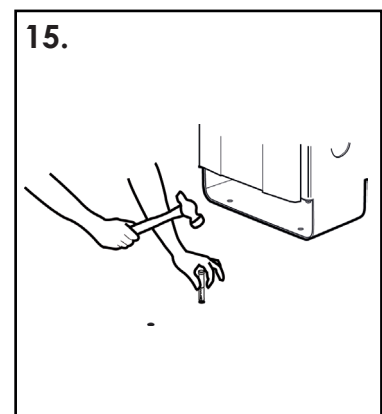

15. Take the four Anchor Rawl Plugs (ITEM 1) and using a hammer gently tap them into the four ground fixing holes.

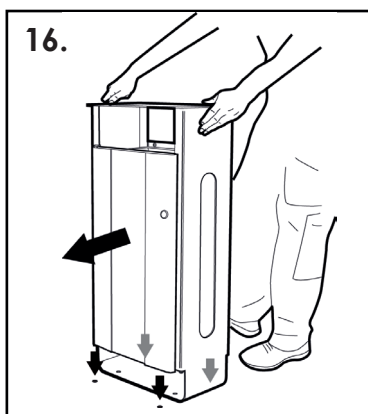

16. Place the bin back into position. Take care to align the ground fixing holes.

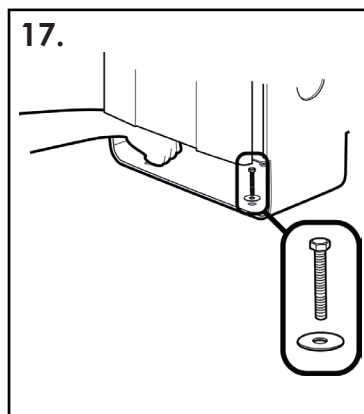

17. Take the M10 Screws (ITEM 2) and Washers (ITEM 3) and fit them through the base of the bin and into the ground anchor sleeves fitted into the concrete.

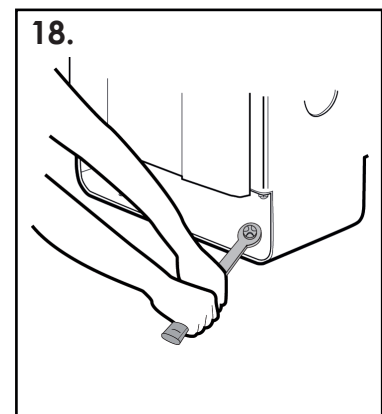

18. Tighten the M10 Screws using a Socket Wrench fitted with a 17mm Socket or 17mm Spanner - (maximum recommended torque setting is 40Nm).

# ELECTRA™ BIN

## Operator Instruction Leaflet

### To Install the Litter Bin (Concrete-In).

#### KIT CONTENTS:

ITEM 4 - Adjustable Depth Concrete-in Fixing	x 4
ITEM 5 - M10 x 50mm Washer (Zinc Plated)	x 4
ITEM 6 - M10 Wing Nut	x 8
ITEM 7 - Screw (M10 x 100mm)	x 4
ITEM 8 - M10 x 50mm Washer (Stainless)	x 4

#### TOOLS REQUIRED:

Equipment to excavate hole.
Concrete Mix.
Spirit Level.
17mm Socket Set or 17mm Spanner.
Lubricant or Grease.

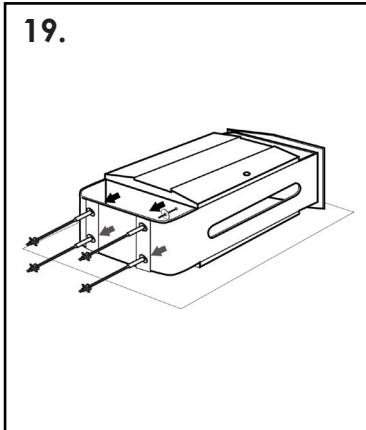

19. Lay the bin on its back (onto a soft surface which will not cause damage to the product). Attach the four concrete fixings (ITEM 4) through the ground fixing holes as shown. Use a 17mm Spanner or Socket Wrench to secure.

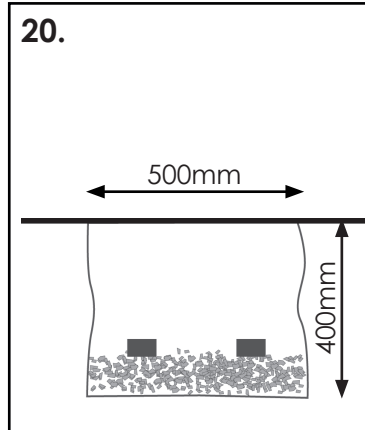

20. Prepare a hole.

- Electra 60L- 500mm long, 350mm wide, 400 deep.
- Electra 85L- 500mm long, 500mm wide, 400mm deep.

Fill the base with an 80mm deep layer of fine gravel. Place support blocks under the positions where the concrete fixings will rest at the base of the hole.

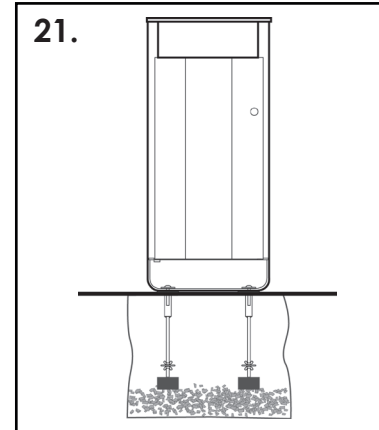

21. Fit the bin into the hole to test the depth and level of the hole. Adjust the support blocks and depth of the gravel until the base supports the bin so that the base sits level with the ground surface and is vertically level.

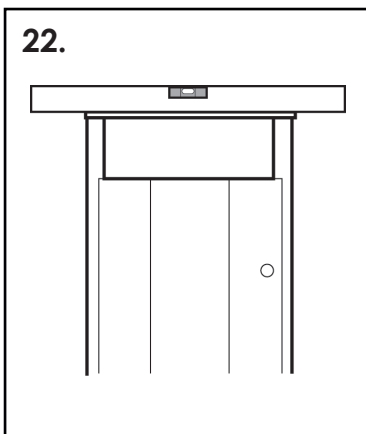

22. Use a spirit level to check the alignment in all orientations.

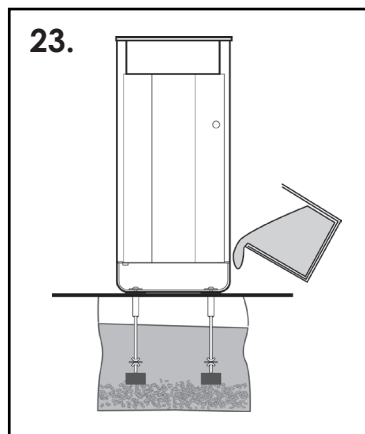

23. Pour in the concrete mix to the desired level.

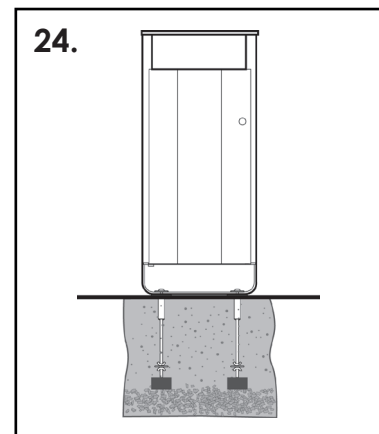

24. Wipe away any excess concrete around the base.

 **Glasdon** AND ELECTRA BIN ARE TRADEMARKS OF GLASDON GROUP OR ITS SUBSIDIARIES IN THE U.K. AND OTHER COUNTRIES

- A planned maintenance schedule or regular inspection is recommended, replacing components as necessary.
- Replacement components are available direct from GLASDON.
- GLASDON cannot be held responsible for claims arising from incorrect installation, unauthorised modifications or misuse of the product.

Stock No. C000/0480      DWG No. 07B-354-34      Issue 3 - March 2019

© Copyright February 2016  
Glasdon UK Ltd reserve the right to alter specifications without prior notice.

**Glasdon®**

**Glasdon U.K. Limited**  
Preston New Road  
BLACKPOOL  
Lancashire  
FY4 4UL  
Tel: (01253) 600410  
Fax: (01253) 792558  
e-mail: sales@glasdon-uk.co.uk  
web: www.glasdon.com