

Tower Crane 710 HC-L 32/64 Litronic® Fly-Jib

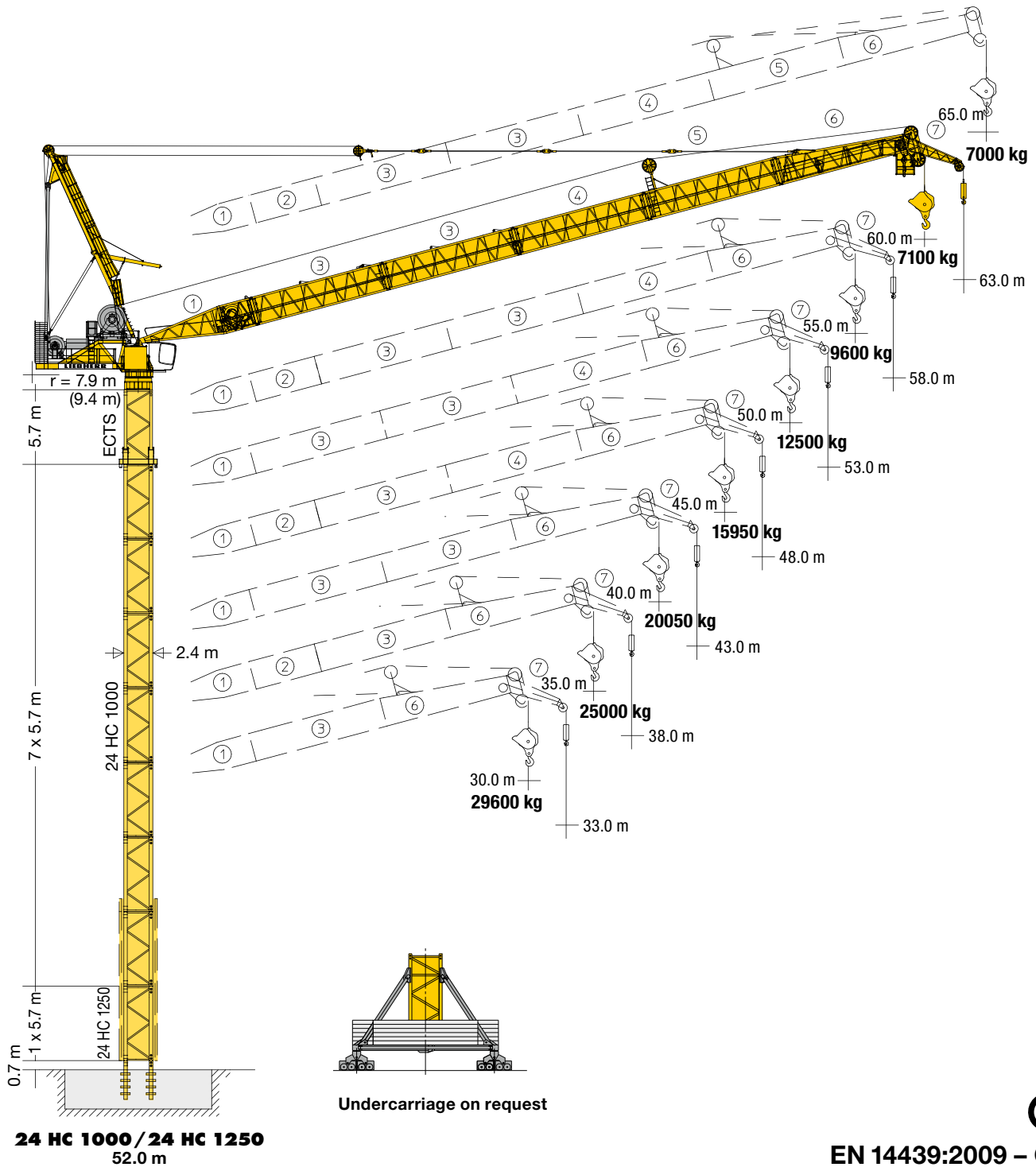

EN 14439:2009 – C25

LIEBHERR

Radius and hoisting height

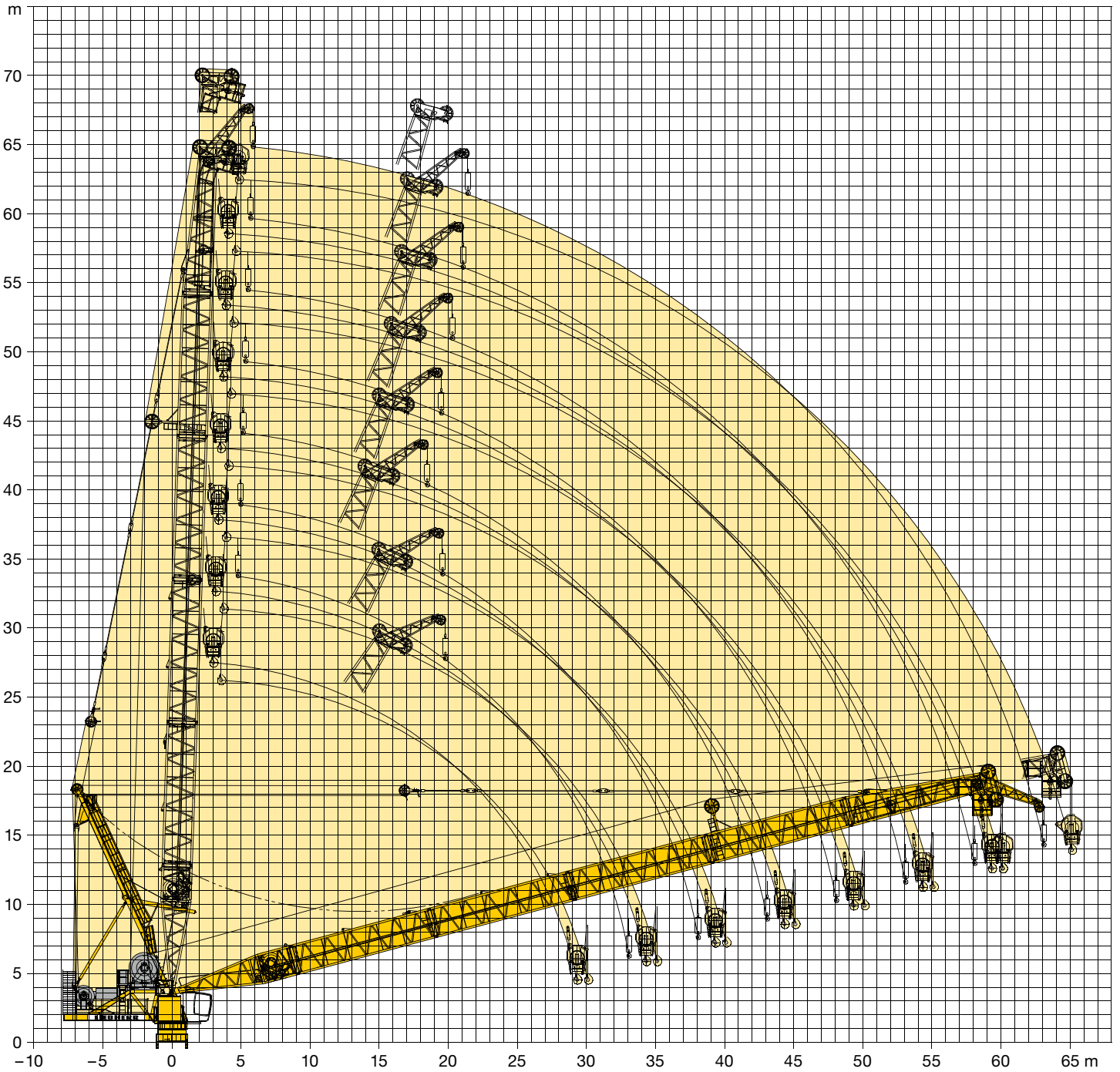

Minimum radius out of operation

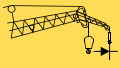
| Jib (m) | Out-of-operation position (α°) | | | |
|---------|--|------------------|--------------------|---|
| | α | \downarrow (m) | \downarrow Q (m) |  |
| 65 | 75° | 19.6 | - | - |
| 60 | 74° | 19.3 | 18.8 | 21.2 |
| 55 | 73° | 18.8 | 18.1 | 20.7 |
| 50 | 72° | 18.1 | 17.4 | 20.1 |
| 45 | 71° | 17.2 | 16.6 | 19.3 |
| 40 | 70° | 16.2 | 15.5 | 18.3 |
| 35 | 65° | 17.2 | 16.5 | 19.5 |
| 30 | 60° | 17.3 | 16.5 | 19.7 |

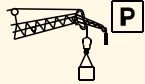
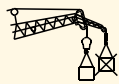
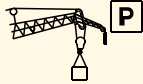
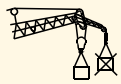

Radius and capacity

| m | | m/kg | | Main hook only | | | | | | | | |
|------|--|---------------------|--|---|-------|-----------------|-----------------|-----------------|-----------------|-----------------|----------------|----------------|
| | | | |     | | | | | | | | |
| | | | | With Fly-Jib – Out of operation. Fly-Jib hook in upper position. (P = Parking position) | | | | | | | | |
| | | | | 20.0 | 25.0 | 30.0 | 35.0 | 40.0 | 45.0 | 50.0 | 55.0 | 60.0 |
| 60.0 | | 4.6 – 24.4 32000 | | 32000 | 31010 | 24350 | 19550 | 15920 | 13060 | 10730 | 8800 | 7100 |
| | | 4.1 – 16.2 48000 | | 37010 | 27630 | 21310 | 16740 | 13260 | 10510 | 8270 | 6410 | 59.3 m 5000 |
| 55.0 | | 4.5 – 26.0 32000 | | 32000 | 32000 | 26470 | 21300 | 17390 | 14290 | 11770 | 9600 | |
| | | 3.9 – 15.5 54000 | | 39670 | 29790 | 23130 | 18310 | 14640 | 11730 | 9360 | 54.3 m 7600 | |
| 50.0 | | 4.3 – 27.5 32000 | | 32000 | 32000 | 28480 | 22910 | 18680 | 15330 | 12500 | | |
| | | 3.7 – 15.0 60000 | | 42500 | 32000 | 24920 | 19790 | 15880 | 12770 | 49.3 m 10500 | | |
| 45.0 | | 4.1 – 28.9 32000 | | 32000 | 32000 | 30390 | 24330 | 19710 | 15950 | | | |
| | | 3.6 – 14.7 64000 | | 44410 | 33540 | 26200 | 20880 | 16800 | 44.3 m 13900 | | | |
| 40.0 | | 3.9 – 29.9 32000 | | 32000 | 32000 | 31840 | 25250 | 20050 | | | | |
| | | 3.4 – 15.2 64000 | | 46250 | 34980 | 27380 | 21820 | 39.3 m 18000 | | | | |
| 35.0 | | 3.7 – 31.2 32000 | | 32000 | 32000 | 32000 | 25000 | | | | | |
| | | 3.2 – 15.6 64000 | | 47450 | 35670 | 27670 | 34.3 m 22400 | | | | | |
| 30.0 | | 3.6 – 28.8 32000 | | 32000 | 32000 | 29600 | | | | | | |
| | | 3.0 – 15.7 64000 | | 47220 | 34850 | 29.3 m 27200 | | | | | | |

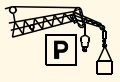
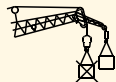
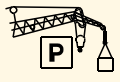
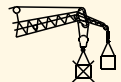
| m | | m/kg | | Fly-Jib only | | | | | | | |
|-------------------|-------------|---------|---------------------|---|-------|-------|-------|-------|-------|------|------|
| | | | |     | | | | | | | |
| | | | | With Fly-Jib – In operation. Main hook in upper position. (P = Parking position) | | | | | | | |
| | | | | 28.0 | 33.0 | 38.0 | 43.0 | 48.0 | 53.0 | 58.0 | 63.0 |
| 60.0 | 63.1 | Fly-Jib | 5.9 – 46.2 13100 | 13100 | 13100 | 13100 | 13100 | 12240 | 10190 | 8490 | 7000 |
| | 60.0 | | - | - | - | - | - | - | - | - | - |
| 55.0 | 58.1 | Fly-Jib | 5.8 – 48.3 13100 | 13100 | 13100 | 13100 | 13100 | 13100 | 11080 | 9200 | |
| | 55.0 | | - | - | - | - | - | - | - | - | |
| 50.0 | 53.1 | Fly-Jib | 5.6 – 49.8 13100 | 13100 | 13100 | 13100 | 13100 | 13100 | 11600 | | |
| | 50.0 | | - | - | - | - | - | - | - | | |
| 45.0 - 30.0 | 48.1 – 33.0 | Fly-Jib | 4.9 – 48.1 13100 | 13100 | 13100 | 13100 | 13100 | 13100 | | | |
| | 45.0 – 30.0 | | - | - | - | - | - | - | | | |
| 60.0 | 63.1 | Fly-Jib | 5.9 – 42.4 13100 | 13100 | 13100 | 13100 | 12780 | 10450 | 8590 | 7050 | 5700 |
| | 59.3 | | - | - | - | - | - | - | - | - | - |
| 55.0 | 58.1 | Fly-Jib | 5.8 – 44.6 13100 | 13100 | 13100 | 13100 | 13100 | 11520 | 9580 | 7900 | |
| | 54.3 | | - | - | - | - | - | - | - | - | |
| 50.0 | 53.1 | Fly-Jib | 5.6 – 46.9 13100 | 13100 | 13100 | 13100 | 13100 | 12600 | 10500 | | |
| | 49.3 | | - | - | - | - | - | - | - | | |
| 45.0 - 30.0 | 48.1 – 33.0 | Fly-Jib | 4.9 – 48.1 13100 | 13100 | 13100 | 13100 | 13100 | 13100 | | | |
| | 44.3 – 29.3 | | - | - | - | - | - | - | | | |



Radius and capacity

| | | | | | | Main hook and Fly-Jib Function: „Turning“ | | | | | | | | |
|------|------|---------|--------|-------|---|--|-------|--|-------|-------|-------|------|-----------------|--|
| | | | | | | $X + Y = Z$ | | With Fly-Jib – In operation. Main hook with Fly-Jib-Hook Load X and Load Y = Total load Z | | | | | $X + Y = Z$ | |
| | | | | | | m/kg | | | | | | | | |
| m | m | kg | m | kg | | | 33.0 | 38.0 | 43.0 | 48.0 | 53.0 | 58.0 | 63.0 | |
| 60.0 | 63.1 | Fly-Jib | - 45.0 | 13100 | Y | Z | 19700 | 17490 | 14190 | 11640 | 9590 | 7890 | 6400 | |
| | 60.0 | | - 35.3 | 19700 | X | | | | | | | | | |
| 55.0 | 58.1 | Fly-Jib | - 47.3 | 13100 | Y | Z | 19700 | 19110 | 15550 | 12780 | 10540 | 8600 | | |
| | 55.0 | | - 37.3 | 19700 | X | | | | | | | | | |
| 50.0 | 53.1 | Fly-Jib | - 49.2 | 13100 | Y | Z | 19700 | 19700 | 16920 | 13770 | 11150 | | | |
| | 50.0 | | - 39.4 | 19700 | X | | | | | | | | | |
| 45.0 | 48.1 | Fly-Jib | - 48.1 | 13100 | Y | Z | 19700 | 19700 | 16970 | 13550 | | | | |
| | 45.0 | | - 39.6 | 19700 | X | | | | | | | | | |
| 40.0 | 43.1 | Fly-Jib | - 43.1 | 13100 | Y | Z | 19700 | 19700 | 16650 | | | | | |
| | 40.0 | | - 39.7 | 19700 | X | | | | | | | | | |
| 35.0 | 38.0 | Fly-Jib | - 38.0 | 13100 | Y | Z | 19700 | 19700 | | | | | | |
| | 35.0 | | - 38.0 | 19700 | X | | | | | | | | | |
| 30.0 | 33.0 | Fly-Jib | - 33.0 | 13100 | Y | Z | 19700 | | | | | | | |
| | 30.0 | | - 33.0 | 19700 | X | | | | | | | | | |
| | | | | | | m/kg | | | | | | | | |
| m | m | kg | m | kg | | | 33.0 | 38.0 | 43.0 | 48.0 | 53.0 | 58.0 | 63.0 | |
| 60.0 | 63.1 | Fly-Jib | - 40.6 | 13100 | Y | Z | 19000 | 14850 | 11740 | 9330 | 7400 | 5810 | 4400 | |
| | 60.0 | | - 32.3 | 19700 | X | | | | | | | | | |
| 55.0 | 58.1 | Fly-Jib | - 43.0 | 13100 | Y | Z | 19700 | 16440 | 13110 | 10510 | 8420 | 6600 | | |
| | 55.0 | | - 34.2 | 19700 | X | | | | | | | | | |
| 50.0 | 53.1 | Fly-Jib | - 45.5 | 13100 | Y | Z | 19700 | 18290 | 14620 | 11750 | 9300 | | | |
| | 50.0 | | - 36.4 | 19700 | X | | | | | | | | | |
| 45.0 | 48.1 | Fly-Jib | - 46.6 | 13100 | Y | Z | 19700 | 19250 | 15400 | 12250 | | | | |
| | 45.0 | | - 37.5 | 19700 | X | | | | | | | | | |
| 40.0 | 43.1 | Fly-Jib | - 43.1 | 13100 | Y | Z | 19700 | 19500 | 15150 | | | | | |
| | 40.0 | | - 37.8 | 19700 | X | | | | | | | | | |
| 35.0 | 38.0 | Fly-Jib | - 38.0 | 13100 | Y | Z | 19700 | 19200 | | | | | | |
| | 35.0 | | - 37.6 | 19700 | X | | | | | | | | | |
| 30.0 | 33.0 | Fly-Jib | - 33.0 | 13100 | Y | Z | 19700 | | | | | | | |
| | 30.0 | | - 33.0 | 19700 | X | | | | | | | | | |



Tower heights

| 5,70 m + 2,85 m | | 24 HC 1000 / 24 HC 1250 | | | | | | |
|---|--------|--|--|--|--|--|--|--|
|  ECTS ⁶⁾ | | Jib Fly-Jib Built-on | | | | | | |
| | | 30.0 m | 35.0 m | 40.0 m | 45.0 m | 50.0 m | 55.0 m | 60.0 m |
| 11 | 11 + 1 | 71.9 ¹⁾³⁾ 69.1 ¹⁾²⁾ | — 69.1 ¹⁾⁴⁾ | — — | — — | — — | — — | — — |
| 10 | 10 + 1 | 66.2 ¹⁾¹⁾ 63.4 ¹⁾¹⁾ | 66.2 ¹⁾³⁾ 63.4 ¹⁾²⁾ | 66.2 ¹⁾²⁾⁵⁾ 63.4 ¹⁾²⁾ | — 63.4 ¹⁾²⁾ | — — | — — | — — |
| 9 | 9 + 1 | 60.5 ¹⁾ 57.7 | 60.5 ¹⁾¹⁾ 57.7 ¹⁾ | 60.5 ¹⁾¹⁾ 57.7 ¹⁾ | 60.5 ¹⁾¹⁾⁵⁾ 57.7 ¹⁾¹⁾ | 60.5 ¹⁾¹⁾⁵⁾ 57.7 ¹⁾¹⁾ | 57.7 ¹⁾²⁾ 57.7 ¹⁾²⁾ | — — |
| 8 | 8 + 1 | 54.8 52.0 | 54.8 52.0 | 54.8 52.0 | 54.8 ¹⁾ 52.0 ¹⁾ | 54.8 ¹⁾ 52.0 ¹⁾ | 54.8 ¹⁾¹⁾ 52.0 ¹⁾ | — 52.0 ¹⁾¹⁾ |
| 7 | 7 + 1 | 49.1 46.3 | 49.1 46.3 | 49.1 46.3 | 49.1 46.3 | 49.1 46.3 | 49.1 ¹⁾ 46.3 | 49.1 ¹⁾⁵⁾ 46.3 ¹⁾ |
| 6 | 6 + 1 | 43.4 40.6 | 43.4 40.6 | 43.4 40.6 | 43.4 40.6 | 43.4 40.6 | 43.4 40.6 | 43.4 40.6 |
| 5 | 5 + 1 | 37.7 34.9 | 37.7 34.9 | 37.7 34.9 | 37.7 34.9 | 37.7 34.9 | 37.7 34.9 | 37.7 34.9 |
| 4 | 4 + 1 | 32.0 29.2 | 32.0 29.2 | 32.0 29.2 | 32.0 29.2 | 32.0 29.2 | 32.0 29.2 | 32.0 29.2 |
| 3 | 3 + 1 | 26.3 23.5 | 26.3 23.5 | 26.3 23.5 | 26.3 23.5 | 26.3 23.5 | 26.3 23.5 | 26.3 23.5 |
| 2 | 2 + 1 | 20.6 17.8 | 20.6 17.8 | 20.6 17.8 | 20.6 17.8 | 20.6 17.8 | 20.6 17.8 | 20.6 17.8 |
| 1 | 1 + 1 | 14.9 12.1 | 14.9 12.1 | 14.9 12.1 | 14.9 12.1 | 14.9 12.1 | 14.9 12.1 | 14.9 12.1 |
| 0 | 0 + 1 | 9.2 6.4 | 9.2 6.4 | 9.2 6.4 | 9.2 6.4 | 9.2 6.4 | 9.2 6.4 | 9.2 6.4 |
| | | m | | | | | | |

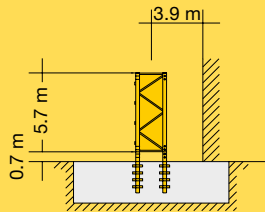

24 HC 1000 FA / 24 HC 1250 FA



- ¹⁾ 1 x 24 HC 1250 TS-0570c (5.7 m)
- ²⁾ 2 x 24 HC 1250 TS-0570c (5.7 m)
- ³⁾ 3 x 24 HC 1250 TS-0570c (5.7 m)
- ⁴⁾ 4 x 24 HC 1250 TS-0570c (5.7 m)
- ⁵⁾ 1 x 24 HC 1250 TS-0285c (2.85 m)
- ⁶⁾ 24 HC 1000 ECTS-0570

Tower sections 24 HC 1250 must be installed on the tower base. See operating manual for further details.



Climbing in the building

| n | | 24 HC 1000 | | | | | |
|--------------------|-------|------------|--------|--------|---------------|--------|--------|
| | | Jib | | | | | |
| 5.70 m + 2.85 m | | 30.0 m | 35.0 m | 40.0 m | 45.0 m/50.0 m | 55.0 m | 60.0 m |
| 10 | 9 + 1 | 62.7 | — | — | — | — | — |
| 9 | 8 + 1 | 59.8 | 59.8 | 57.0 | 54.1 | 51.3 | 48.4 |
| 8 | 7 + 1 | 57.0 | 57.0 | 54.1 | 51.3 | 48.4 | 45.6 |
| 7 | 6 + 1 | 54.1 | 54.1 | 48.4 | 45.6 | 42.7 | 39.9 |
| 6 | 5 + 1 | 51.3 | 51.3 | 45.6 | 42.7 | 39.9 | 37.0 |
| 5 | 4 + 1 | 48.4 | 48.4 | 42.7 | 39.9 | 37.0 | 34.2 |
| 4 | 3 + 1 | 45.6 | 45.6 | 39.9 | 37.0 | 34.2 | 31.3 |
| 3 | 2 + 1 | 42.7 | 42.7 | 37.0 | 34.2 | 31.3 | 28.5 |
| 2 | 1 + 1 | 39.9 | 39.9 | 34.2 | 31.3 | 28.5 | 25.6 |
| 1 | 0 + 1 | 37.0 | 37.0 | 31.3 | 28.5 | 25.6 | 22.8 |
| 0 | | 34.2 | 34.2 | 28.5 | 25.6 | 22.8 | 19.9 |
| | | 31.3 | 31.3 | 25.6 | 22.8 | 19.9 | 17.1 |
| | | 28.5 | 28.5 | 19.9 | 17.1 | 14.2 | 11.4 |
| | | 25.6 | 25.6 | 14.2 | 11.4 | 8.5 | 5.7 |
| | | 22.8 | 22.8 | 11.4 | 8.5 | 5.7 | |
| | | 19.9 | 19.9 | 8.5 | 5.7 | | |
| | | 17.1 | 17.1 | 5.7 | | | |
| | | 14.2 | 14.2 | | | | |
| | | 11.4 | 11.4 | | | | |
| | | 8.5 | 8.5 | | | | |
| | | 5.7 | 5.7 | | | | |

Tower heights on foundation anchors: + 0.7 m
 Min. anchoring height may deviate at max. tower height resp. hook height > 100 m.
 See operating manual for further details.



Radius and capacity

| m | | m/kg | Fly-Jib preparation | | | | | | | | | |
|------|--|----------------------------|---------------------|-------|------------------------|------------------------|------------------------|------------------------|------------------------|-----------------------|-----------------------|------|
| | | | m/kg | | 20.0 | 25.0 | 30.0 | 35.0 | 40.0 | 45.0 | 50.0 | 55.0 |
| 65.0 | | 4.8 – 23.8 32000 | 32000 | 30230 | 24320 | 19980 | 16650 | 13990 | 11810 | 9970 | 8410 | 7000 |
| | | 4.6 – 25.8 32000 | 32000 | 32000 | 26730 | 21990 | 18350 | 15440 | 13050 | 11030 | 9250 | |
| 60.0 | | 4.1 – 16.9 48000 | 39780 | 30600 | 24290 | 19630 | 16030 | 13150 | 10770 | 8770 | 59.3 m 7250 | |
| | | 4.5 – 27.5 32000 | 32000 | 32000 | 28820 | 23740 | 19820 | 16690 | 14100 | 11850 | | |
| 55.0 | | 3.9 – 16.2 54000 | 42790 | 32990 | 26240 | 21260 | 17410 | 14320 | 11760 | 54.3 m 9850 | | |
| | | 4.3 – 29.1 32000 | 32000 | 32000 | 30830 | 25360 | 21140 | 17750 | 14850 | | | |
| 50.0 | | 3.7 – 15.5 60000 | 45390 | 35040 | 27900 | 22640 | 18560 | 15270 | 49.3 m 12850 | | | |
| | | 4.1 – 30.5 32000 | 32000 | 32000 | 32000 | 26760 | 22180 | 18400 | | | | |
| 45.0 | | 3.6 – 15.3 64000 | 47750 | 36860 | 29350 | 23790 | 19460 | 44.3 m 16350 | | | | |
| | | 3.9 – 31.6 32000 | 32000 | 32000 | 32000 | 27790 | 22600 | | | | | |
| 40.0 | | 3.4 – 15.8 64000 | 49440 | 38170 | 30380 | 24590 | 39.3 m 20550 | | | | | |
| | | 3.7 – 32.5 32000 | 32000 | 32000 | 32000 | 27600 | | | | | | |
| 35.0 | | 3.2 – 16.3 64000 | 50850 | 38940 | 30660 | 34.3 m 25100 | | | | | | |
| | | 3.6 – 29.7 32000 | 32000 | 32000 | 31750 | | | | | | | |
| 30.0 | | 3.0 – 16.3 64000 | 50370 | 37950 | 29.3 m 30100 | | | | | | | |
| | | | | | | | | | | | | |



Tower heights

| 5,70 m + 2,85 m | | 24 HC 1000 / 24 HC 1250 | | | | | | | |
|--------------------|--------|--|--|--|---|--------------------------------|--------------------------------|----------------------|----------------------|
| ECTS ⁶⁾ | | Jib for Fly-Jib prepared | | | | | | | |
| | | 30.0 m | 35.0 m | 40.0 m | 45.0 m | 50.0 m | 55.0 m | 60.0 m | 65.0 m |
| 12 | 11 + 1 | 74.8 ¹⁾³⁾ 71.9 ¹⁾²⁾⁴⁾ | — 71.9 ¹⁾³⁾⁴⁾ | — — | — — | — — | — — | — — | — — |
| 11 | 10 + 1 | 69.1 ¹⁾²⁾ 66.2 ¹⁾¹⁾⁴⁾ 63.4 ¹⁾ | 69.1 ¹⁾³⁾ 66.2 ¹⁾²⁾ 63.4 ¹⁾¹⁾ | 69.1 ¹⁾³⁾ 66.2 ¹⁾²⁾⁴⁾ 63.4 ¹⁾²⁾ | — 66.2 ¹⁾²⁾⁴⁾ 63.4 ¹⁾²⁾ | — — 63.4 ¹⁾²⁾ | — — 60.5 ¹⁾²⁾ | — — — | — — — |
| 10 | 9 + 1 | 60.5 | 60.5 ¹⁾ | 60.5 ¹⁾⁴⁾ | 60.5 ¹⁾¹⁾⁴⁾ | 60.5 ¹⁾¹⁾ | 60.5 ¹⁾²⁾ | — | — |
| 9 | 8 + 1 | 57.7 | 57.7 | 57.7 ¹⁾ | 57.7 ¹⁾ | 57.7 ¹⁾¹⁾ | 57.7 ¹⁾¹⁾ | 54.8 ¹⁾⁴⁾ | 54.8 ¹⁾¹⁾ |
| 8 | 7 + 1 | 54.8 | 54.8 | 54.8 | 54.8 ¹⁾ | 54.8 ¹⁾ | 54.8 ¹⁾⁴⁾ | 52.0 ¹⁾ | 52.0 ¹⁾¹⁾ |
| 7 | 6 + 1 | 52.0 | 52.0 | 52.0 | 52.0 | 52.0 | 52.0 ¹⁾ | 49.1 ¹⁾ | 49.1 ¹⁾⁴⁾ |
| 6 | 5 + 1 | 49.1 | 49.1 | 49.1 | 49.1 | 49.1 | 49.1 | 46.3 | 46.3 ¹⁾ |
| 5 | 4 + 1 | 46.3 | 46.3 | 46.3 | 46.3 | 46.3 | 46.3 | 43.4 | 43.4 |
| 4 | 3 + 1 | 43.4 | 43.4 | 43.4 | 43.4 | 43.4 | 43.4 | 40.6 | 40.6 |
| 3 | 2 + 1 | 40.6 | 40.6 | 40.6 | 40.6 | 40.6 | 40.6 | 37.7 | 37.7 |
| 2 | 1 + 1 | 37.7 | 37.7 | 37.7 | 37.7 | 37.7 | 37.7 | 34.9 | 34.9 |
| 1 | 0 + 1 | 34.9 | 34.9 | 34.9 | 34.9 | 34.9 | 34.9 | 32.0 | 32.0 |
| 0 | | 32.0 | 32.0 | 32.0 | 32.0 | 32.0 | 32.0 | 29.2 | 29.2 |
| | | 29.2 | 29.2 | 29.2 | 29.2 | 29.2 | 29.2 | 26.3 | 26.3 |
| | | 26.3 | 26.3 | 26.3 | 26.3 | 26.3 | 26.3 | 23.5 | 23.5 |
| | | 23.5 | 23.5 | 23.5 | 23.5 | 23.5 | 23.5 | 20.6 | 20.6 |
| | | 20.6 | 20.6 | 20.6 | 20.6 | 20.6 | 20.6 | 17.8 | 17.8 |
| | | 17.8 | 17.8 | 17.8 | 17.8 | 17.8 | 17.8 | 14.9 | 14.9 |
| | | 14.9 | 14.9 | 14.9 | 14.9 | 14.9 | 14.9 | 12.1 | 12.1 |
| | | 12.1 | 12.1 | 12.1 | 12.1 | 12.1 | 12.1 | 9.2 | 9.2 |
| | | 9.2 | 9.2 | 9.2 | 9.2 | 9.2 | 9.2 | 6.4 | 6.4 |
| | | 6.4 | 6.4 | 6.4 | 6.4 | 6.4 | 6.4 | | |

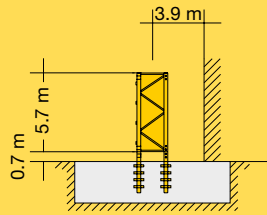

24 HC 1000 FA / 24 HC 1250 FA



- ¹⁾ 1 x 24 HC 1250 TS-0570c (5.7 m)
- ²⁾ 2 x 24 HC 1250 TS-0570c (5.7 m)
- ³⁾ 3 x 24 HC 1250 TS-0570c (5.7 m)
- ⁴⁾ 4 x 24 HC 1250 TS-0570c (5.7 m)
- ⁶⁾ 24 HC 1000 ECTS-0570

Tower sections 24 HC 1250 must be installed on the tower base. See operating manual for further details.



Climbing in the building

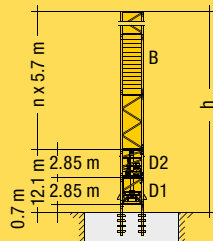

| n | | 24 HC 1000 | | | | | | |
|--------------------|--------|------------|--------|--------|---------------|--------|--------|--------|
| | | Jib | | | | | | |
| 5.70 m + 2.85 m | | 30.0 m | 35.0 m | 40.0 m | 45.0 m/50.0 m | 55.0 m | 60.0 m | 65.0 m |
| 10 | 10 + 1 | 65.5 | — | — | — | — | — | — |
| | 9 + 1 | 62.7 | 62.7 | — | — | — | — | — |
| 9 | | 59.8 | 59.8 | 59.8 | — | — | — | — |
| | 8 + 1 | 57.0 | 57.0 | 57.0 | 57.0 | — | — | — |
| 8 | | 54.1 | 54.1 | 54.1 | 54.1 | 54.1 | — | — |
| | 7 + 1 | 51.3 | 51.3 | 51.3 | 51.3 | 51.3 | 51.3 | — |
| 7 | | 48.4 | 48.4 | 48.4 | 48.4 | 48.4 | 48.4 | 48.4 |
| | 6 + 1 | 45.6 | 45.6 | 45.6 | 45.6 | 45.6 | 45.6 | 45.6 |
| 6 | | 42.7 | 42.7 | 42.7 | 42.7 | 42.7 | 42.7 | 42.7 |
| | 5 + 1 | 39.9 | 39.9 | 39.9 | 39.9 | 39.9 | 39.9 | 39.9 |
| 5 | | 37.0 | 37.0 | 37.0 | 37.0 | 37.0 | 37.0 | 37.0 |
| | 4 + 1 | 34.2 | 34.2 | 34.2 | 34.2 | 34.2 | 34.2 | 34.2 |
| 4 | | 31.3 | 31.3 | 31.3 | 31.3 | 31.3 | 31.3 | 31.3 |
| | 3 + 1 | 28.5 | 28.5 | 28.5 | 28.5 | 28.5 | 28.5 | 28.5 |
| 3 | | 25.6 | 25.6 | 25.6 | 25.6 | 25.6 | 25.6 | 25.6 |
| | 2 + 1 | 22.8 | 22.8 | 22.8 | 22.8 | 22.8 | 22.8 | 22.8 |
| 2 | | 19.9 | 19.9 | 19.9 | 19.9 | 19.9 | 19.9 | 19.9 |
| | 1 + 1 | 17.1 | 17.1 | 17.1 | 17.1 | 17.1 | 17.1 | 17.1 |
| 1 | | 14.2 | 14.2 | 14.2 | 14.2 | 14.2 | 14.2 | 14.2 |
| | 0 + 1 | 11.4 | 11.4 | 11.4 | 11.4 | 11.4 | 11.4 | 11.4 |
| 0 | | 8.5 | 8.5 | 8.5 | 8.5 | 8.5 | 8.5 | 8.5 |
| | m | 5.7 | 5.7 | 5.7 | 5.7 | 5.7 | 5.7 | 5.7 |



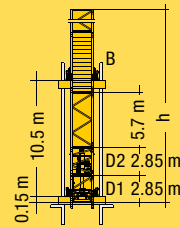
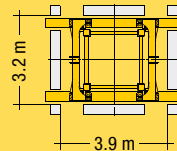

24 HC 1000 FA

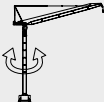
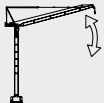

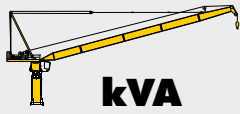

Tower heights on foundation anchors: + 0.7 m
 Min. anchoring height may deviate at max. tower height resp. hook height > 100 m.
 See operating manual for further details.



| | | |
|---|---------------------------------|--------------|
|  | 0 ↔ 0.6 U/min | 2 x 11 kW FU |
|  | 1.4 ↔ 2.0 min | 160 kW FU |
|  | Undercarriage on request | |

| | | |
|---|---|-------------------|
|  |  | 2 x 110 kW FU |
| |  | 110 kW FU Fly-Jib |
| | | 160 kW FU |
| | | 379 |

kVA can be reduced in case of too little power of the mains, see instruction manual.

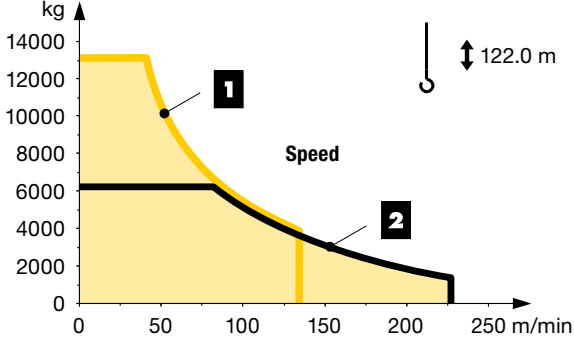
| | | | |
|---|---|-------------------|------------------------------|
| Fly-Jib |  | ↔ stepless | |
| | max. 512 m | kg | m/min |
|  | 110 kW FU [SD.shift] WIW 300 WZ 405 | 4 Layers | |
| | | 1 | 13100 0 ↔ 41 3400 0 ↔ 134 |
| | | 2 | 6200 0 ↔ 83 1400 0 ↔ 227 |





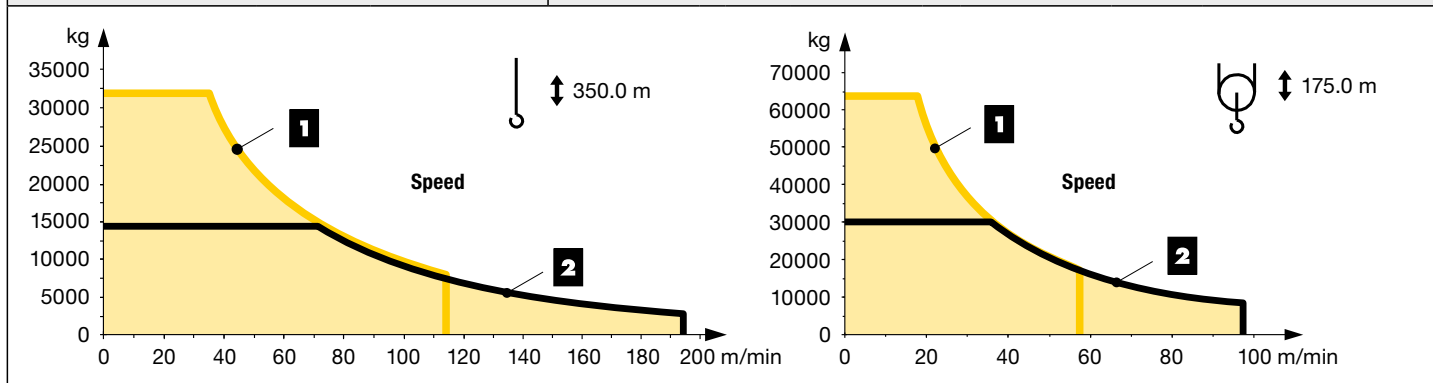





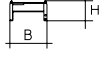

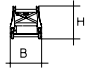

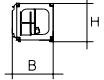





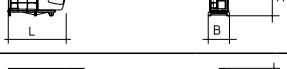

| | | | | | | | |
|--|---|-------------------|------------------------------|----------|------------------------------|--|--|
|  |  | ↔ stepless | | | | | |
| | max. 1067 m | kg | m/min | kg | m/min | | |
|  | 2 x 110 kW FU [SD.shift] WIW 330 WZ 402 | 4 Layers | | | | | |
| | | 1 | 32000 0 ↔ 35 7800 0 ↔ 114 | 1 | 64000 0 ↔ 18 17300 0 ↔ 57 | | |
| | | 2 | 14500 0 ↔ 71 2800 0 ↔ 194 | 2 | 30000 0 ↔ 36 8700 0 ↔ 97 | | |

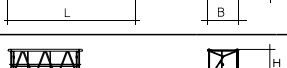



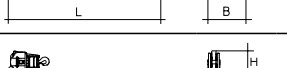
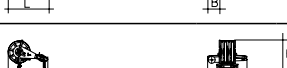
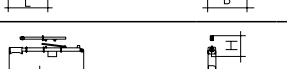
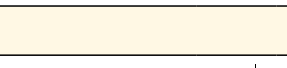
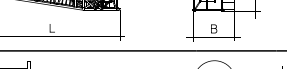

Packing List

Erection weights: see instruction manual.



| Upper part of crane | | | | L (m) | W (m) | H (m) | kg ⁷⁾ | |
|----------------------------|------|--|---|---|-------|-------|------------------|-------|
| Item | Qty. | | | | | | | |
| 1 | 1 | Slewing ring support |  |  | 2.32 | 2.32 | 1.26 | 4610 |
| 2 | 1 | Frame |  |  | 2.81 | 2.28 | 2.39 | 3870 |
| 3 | 1 | Slewing platform with roller slewing ring and slewing ring support |  |  | 3.33 | 2.32 | 2.58 | 14230 |

| Item. | Qty. | | | L (m) | W (m) | H (m) | kg ⁷⁾ |
|----------------|------|--|---|-------|-------|-------|------------------|
| 4 | 1 | Slewing platform with roller slewing ring and slewing ring support and frame |  | 4.73 | 2.58 | 2.41 | 17950 |
| 5 | 1 | Machinery platform with luffing gear | 160 kW  | 7.27 | 2.32 | 2.57 | 16600 |
| 5.1 | 1 | Machinery platform without luffing gear |  | 7.27 | 2.32 | 2.57 | 10930 |
| 6 | 1 | Hoist gear platform with hoist gear | 2 x 110 kW  | 4.74 | 2.29 | 2.57 | 12160 |
| 6.1 | 1 | Hoist gear platform without hoist gear |  | 4.74 | 2.29 | 1.38 | 2910 |
| 7 | 1 | Operator's cab with platform |  | 4.25 | 1.55 | 2.57 | 1245 |
| 8 | 2 | Side platform |  | 5.50 | 1.20 | 1.59 | 420 |
| 9 | 1 | Jib retaining frame |  | 12.10 | 2.27 | 2.40 | 10100 |
| 10 | 1 | Jib heel section "prepared" |  | 9.43 | 2.27 | 2.40 | ① 4320 |
| 11 | 1 | Intermediate jib section (5.18) |  | 5.39 | 2.27 | 2.19 | ② 1410 |
| 12 | 2 | Intermediate jib section (10.36) |  | 10.57 | 2.27 | 2.40 | ③ 2980 |
| 13 | 1 | Intermediate jib section (10.36) |  | 10.57 | 2.27 | 2.19 | ④ 2330 |
| 14 | 1 | Intermediate jib section (10.36) |  | 10.57 | 2.27 | 2.19 | ⑤ 2390 |
| 15 | 1 | Jib head section prepared for Fly-Jib |  | 11.29 | 2.77 | 2.53 | ⑥ 4460 |
| 16 | 1 | Hook block |  | 3.00 | 1.56 | 0.87 | 2580 |
| 17 | 1 | Pulley block |  | 1.45 | 1.43 | 1.14 | 760 |
| 18 | 1 | Auxiliary crane with supports |  | 4.40 | 0.90 | 0.60 | 700 |
| Fly-Jib | | | | | | | |
| 19 | 1 | Jib heel section with Fly-Jib drive and platform |  | 9.43 | 4.00 | 2.40 | ① 8500 |
| 20 | 1 | Fly-Jib drive unit |  | 2.70 | 1.55 | 1.55 | 4240 |
| 21 | 1 | Fly-Jib |  | 8.20 | 0.70 | 1.00 | ⑦ 360 |
| 22 | 1 | Control panel Fly-Jib with platform |  | 2.20 | 1.48 | 2.34 | 950 |
| 23 | 1 | Hook block |  | 1.65 | 0.40 | 0.50 | 850 |





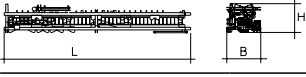



Tower

| Item | Qty. | | | L (m) | W (m) | H (m) | kg ⁷⁾ |
|------|------|-----------------------------------|--|------------------------------|--------------|--------------|------------------|
| 24 | 1 | Tower section 24 HC 1250 |  | 5.70 m: 6.28 2.85 m: 3.43 | 2.44 2.44 | 2.44 2.44 | 9000 5650 |
| 25 | 1 | Tower section 24 HC 1000 |  | 5.70 m: 6.28 2.85 m: 3.43 | 2.43 2.43 | 2.43 2.43 | 8600 5450 |
| 26 | 1 | Climbing tower section 24 HC 1000 |  | 6.28 | 2.43 | 2.61 | 13790 |
| 27 | 1 | Climbing tower section 2 girders |  | 3.04 | 1.83 | 1.41 | 4000 |

Climbing on the building

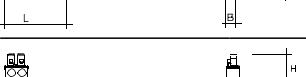
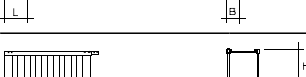
| | | | | | | | |
|----|---|---------------------------------------|--|-------|------|------|-------|
| 28 | 1 | Guide section |  | 13.54 | 2.47 | 2.09 | 22650 |
| 29 | 1 | External frame |  | 13.54 | 2.47 | 2.09 | 22650 |
| 30 | 1 | Hydraulic unit and climbing equipment |  | 4.50 | 1.30 | 2.00 | 3700 |

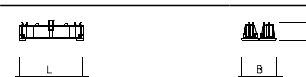
Climbing in the building

| | | | | | | | |
|----|---|--|--|------|------|------|-------|
| 31 | 1 | Climbing tower section D1 + D2 with hydraulic unit |  | 6.36 | 2.46 | 2.48 | 18670 |
| 32 | 1 | Climbing tower section D1 |  | 4.00 | 2.43 | 2.43 | 7730 |
| 33 | 1 | Climbing tower section D2 |  | 2.93 | 2.41 | 2.41 | 6630 |
| 34 | 1 | Climbing cross-member |  | 2.42 | 0.50 | 0.78 | 1450 |
| 35 | 1 | Climbing ram |  | 2.97 | 0.42 | 0.65 | 1640 |
| 36 | 1 | Hydraulic climbing unit |  | 1.52 | 0.70 | 1.80 | 1220 |
| 37 | 1 | Tie-in tower section (B-section) |  | 6.28 | 2.46 | 2.46 | 9300 |
| 38 | 1 | Climbing ladder |  | 5.89 | 0.42 | 0.10 | 580 |
| 39 | 1 | Guide frame (2 pcs.) |  | 9.08 | 1.65 | 1.23 | 4260 |

Ballast

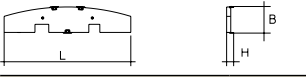
| | | | | | | | |
|----|----|---------------|--|------|------|------|------|
| 40 | 19 | Steel ballast |  | 4.60 | 0.97 | 0.26 | 4075 |
|----|----|---------------|--|------|------|------|------|

Small parts

| | | | | | | | |
|----|---|----------------------|--|--|--|--|------|
| 41 | 1 | Box with small parts | | | | | 4800 |
|----|---|----------------------|--|--|--|--|------|

⁷⁾ Single weights

Subject to alterations!
This information is supplied without liability.

TCS-000881-LBC-01 • EN 14439:2009 – A3 • BGL C.0.11.0710 • 04.19

Printed in Germany.

Liebherr-Werk Biberach GmbH
Postfach 1663, D-88396 Biberach an der Riss
☎ +49 73 51 41-0, Fax: +49 73 51 41 22 25
www.liebherr.com, E-Mail: info.lbc@liebherr.com