

HD 10 C vw



Articulated tandem roller

- ▶ Optimal view due to concave front end
- ▶ Excellent view to the drum edges
- ▶ Clear Side - one-sided drum suspension
- ▶ Offset - crab steering
- ▶ Ergonomic driver's platform
- ▶ Modern instrument panel
- ▶ Low working platform, high stability
- ▶ Low machine height
- ▶ 3-point swivel joint for outstanding driving comfort
- ▶ Central suspension point



TECHNICAL DATA

HD 10C VV

HD 10C VV - Articulated tandem roller

Weights		
Operating weight	kg	1575
Maximum weight	kg	1850
Axle load, front/rear	kg	770/805
Static linear load, front/rear	kg/cm	7,7/8,1
Machine dimensions		
Max. working width	mm	1060
Turning radius, inside	mm	2002
Diesel engine		
Manufacturer		HATZ
Type		3W35
Number of cylinders		3
Power rat. DIN/ISO3046IFN kW/PS/rpm		15,7/21,4/2700
Power rating SAE J1349, kW/HP/rpm		15,7/21,0/2700
Drive		
Hydrostatic drive, front/rear		Hydr. motor/hydr. motor
Speed, infinitely variable	km/h	0 - 10,0
Climbing ability, vibration on/off	%	30/40
Vibration system		
Hydrostatic drive. Front and back vibration lone and double switch, automatic vibration switch-off at overspeed. Manual or automatic vibration control.		
Vibration		
Vibration frequency, front	Hz	62
Vibration frequency, rear	Hz	62
Amplitude, front	mm	0,45
Amplitude, rear	mm	0,45
Centrifugal force, front	kN	24
Centrifugal force, rear	kN	24
Steering		
Steering, type		Pivoted steering
Steering, actuation		hydrostatic, steer. wheel
Steering lock +/-	Grad	33
Oscillation angle +/-	Grad	8
Brake system		
Service brake, mode of action		hydrostatic
Service brake, actuation		Drive lever
Parking brake, mode of action		Spring-loaded/mechanical
Parking brake, actuation		electr. a. autom.
Emergency brake, mode of action		hydr./mech.
Emergency brake, actuation		Emergency stop
Sprinkler system		
Water sprinkler, type		Pressure
Actuation, sprinkling		interval/manual
Water tank, capacity	Ltr.	75

Equipment
50 mm crab steering, suspended driver seat, comfort seat with safety belt, 2 multifunctional control levers, hour meter, pilot lamps and emergency stop device, CE-conformity.

Optional
Lighting according to German Road Regulation, 2 working lamps on ROPS, backup alarm, rotating beacon, special paint, sun top, ROPS, edge pressing and cutting equipment, super noise insulation.

Further data on request / subject to change

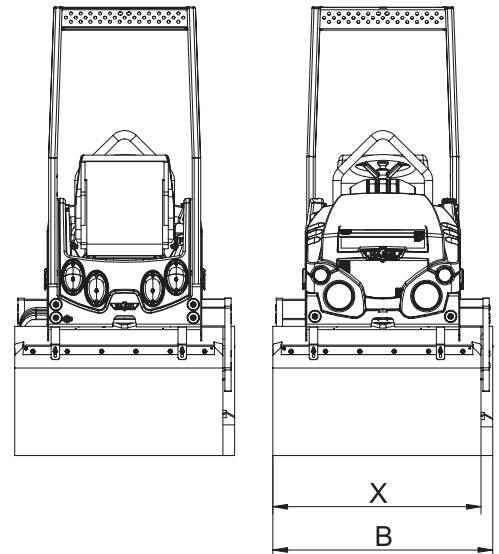
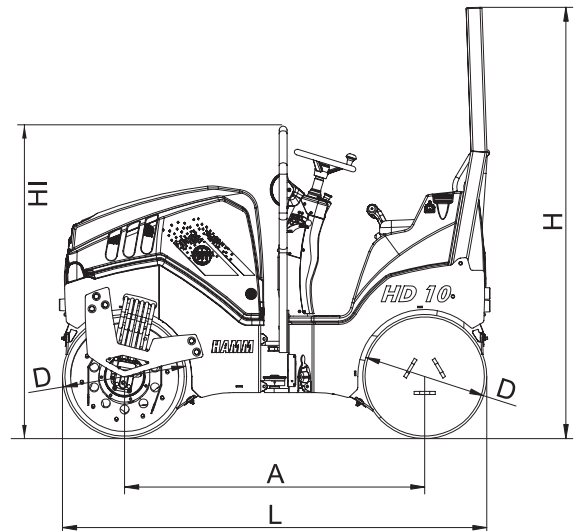

		HD 10C VV
Total length	L	2177
Width	B	1060
Total height	H	2155
Wheel base	A	1500
Roller drum width	X	1000
Drum diameter	D	620
Height loading, min.	HI	1560