

MPM6861T Wireless Pressure and Temperature Transmitter



Features

- NB-IoT / 4G network for application
- Integrated high-energy lithium battery, with service life over 2 years
- Data application in PC and mobile terminals, device data query
- Based on GIS managing system, device status prompt
- Support remote setting for data collecting frequency, data transferring frequency, etc.
- Indicator light alert for device state/ abnormal conditions
- Opened database and interface protocol, and available interface parsing file

Introduction

MPM6861T is an intelligent wireless pressure and temperature transmitter with low power consumption and wireless communication function, which can be connected to two separate temperature and pressure sensors simultaneously. It can be equipped with NB-IoT/4G network. It reports the data according to the set interval and sends alarms to users. Customers can configure the device and inquire for data remotely. All the upload and download data will be stored into the database automatically for later query. It is more intuitive, accurate and efficient through PC or mobile terminals access internet to acquire and analyze data as well as forming with report and data curve. The transmitter can detect the real-time data of many monitoring points in a large area such as fire pipe, fire terminal, fire pump room, urban water supply, petrochemical and other fields that need unattended and remote monitoring.

Specification

Temperature Sensor

- Measuring Range: -50 °C ~150 °C
- Accuracy: $\pm 2.0\%$ °C

Pressure Sensor

- Pressure Range: 0kPa~20kPa...70MPa
- Accuracy: $\pm 0.5\%$ FS
- Over Pressure: 1.5 times FS
- Pressure Type: Absolute/Sealed Gauge
- Long Term Stability: $\pm 0.5\%$ FS/Year
- SIM Card: Nano SIM(12mm×9mm)
- Power Supply: 3.6V@38Ah Lithium Battery
- Display: LCD display
- Keyboard: Panel key triggered
- Setting: In site/Remote control
- Weight: ≥ 1.5 kgs
- Communication Mode: NB-IoT/4G
- Communication Protocol: MQTT
- Consumption: Average current at sending status ≤ 100 mA@3.6V DC, at sleep mode ≤ 25 uA@3.6V DC

Environment Conditions

- Operation Temperature: -20℃ ~70℃
- Storage Temperature: -40℃ ~85℃
- Relative Humidity: 0%~95%
- Protection: IP65

Outline Construction (Unit: mm)

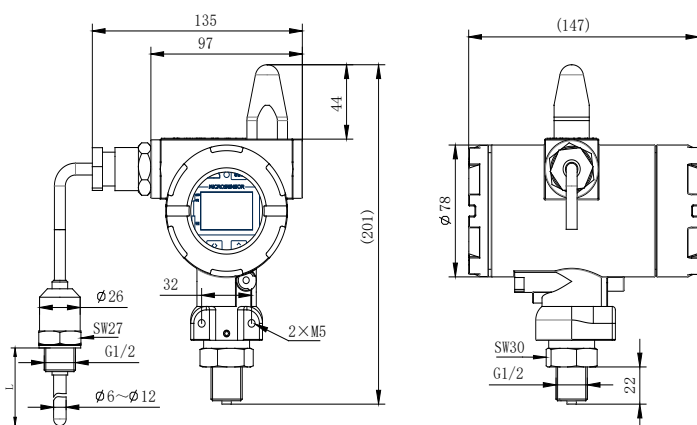

Fig.1 MPM6861T Wireless Pressure and Temperature Transmitter

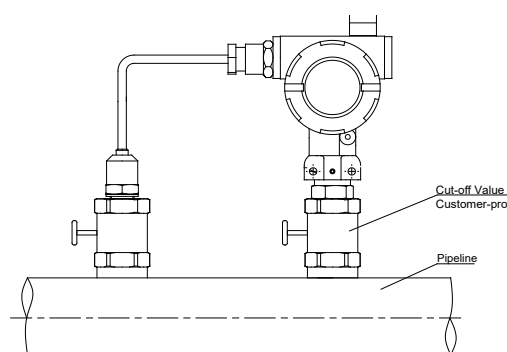

Fig.2 Installation of MPM6861T Wireless Pressure and Temperature Transmitter

Data Transmission

Communication Mode		Standard/Band	Transmission Distance
Multi-Bands	China	TDD-LTE B38/B39/B40/B41 FDD-LTE B1/B3/B8 TD-SCDMA B34/B39 WCDMA B1 CDMA 1X/EVDO BC0 GSM/GPRS/EDGE B3/B8	Global Bands
	Europe / Korea / EMEA / Thailand / India	FDD-LTE B1/B3/B5/B7/B8/B20 WCDMA B1/B5/B8 GSM/GPRS/EDGE B3/B8	
	North America	FDD-LTE B2/B4/B12 WCDMA B2/B5	
	South America / Australia / New Zealand / Taiwan, China	TDD-LTE B40 FDD-LTE B1/B2/B3/B4/B5/B7/B8/B28 WCDMA B1/B2/B5/B8 GSM/GPRS/EDGE B2/B3/B5/B8	
	NB-IoT	B3/B5/B8	

Order Guide

MPM6861T		Wireless Pressure and Temperature Transmitter						
	Range	Measuring Range						
	[0~X]kPa/MPa	X: measured range (0kPa~20kPa...70MPa)						
	[X~Y]°C	X and Y represent the lower and upper limits of the temperature Unit= C ,(-50°C ~150°C)(Default: 0°C ~100°C)						
		Code	Communication Mode					
		GC	4G Multi-Bands in China mainland					
		GE	4G Multi-Bands in EMEA/Korea/Thailand/India					
		GA	4G Multi-Bands in North America					
		GS	4G Multi-Bands in South America/Australia/New Zealand/Taiwan, China					
		GN	NB-IoT					
		GD	4G, 2G and NB-IoT, three-in-one					
		Code	Power Supply					
		N	Without Battery					
		E	Disposable Lithium-thionyl Chloride(Li-SOCI2) Battery(3.6V/38Ah)					
		Code	Antenna Type					
		A1	Integrated Antenna(Recommended)					
		A2	External Sucker Antenna(Length=1m)					
		Code	SIM Card					
		S2	Self-owned SIM card (Data Flow Service Required)					
		Code	Software Service Type					
		M	Micro Sensor Big Data Platform					
		C	Customer Self-built Platform (Note on Docking Mode)					
		Code	Others					
		C1	M20×1.5 Male, face type seal					
		C3	G1/2 Male, face type seal					
		C5	M20×1.5 Male, waterline seal					
		S	Sealed Gauge					
		A	Absolute					
		W	Separated Type Mounting Bracket					
		L5	Probe length L=50mm(customized)					
MPM6861T	[0~2]MPa[0~60]°C	G2	E	A1	S1	M	C1SL5	The whole spec.

1. Please make sure that the measured medium should be compatible with the contact of the product.
2. The minimum range of the absolute type transmitter is 0.1MPa.
3. To improve the reliability of the product, the installation of lightning proof and grounding are highly recommended.
4. Please choose the installation method and mounting interface according to the dimension of the mounting interface. The inserted depth of the probe should not be less than ten times of the diameter of the protective tube.
5. With the further development of the temperature sensor technology, the measurement accuracy of the transmitter is also improved. Please pay attention to choosing the accuracy.
6. The default material of probe is stainless steel 304, unless otherwise specified.
7. The default cooling part length of temperature transmitter is 0mm, please specify if you have special requirement.

Type	Length		Diameter	Note
Length of Cooling Part	Default	0mm		-100℃ <Temp.<100℃
	Customized	20mm~50mm		-200℃ <Temp.<200℃
Probe Length	Default	50mm		
	Customized	5mm~100mm	φ6(default) φ6~φ12	

8. If users need docking platform, please refer to the following (such as: I1);

Classification:

- I1: No docking, Micro Sensor platform is selected;
 - I2: Retrieves data through the API interface;
 - I3: Open limited access to the database and users can retrieve data themselves;
 - I4: Force control configuration docking;
 - I5: Provide communication protocol and users will write the analysis program to complete the docking;
 - I6: Set up the resolution server, deploy the resolver, and deploy the default database (php+apache+Mysql);
 - I7: Set up the resolution server, deploy the specified database resolution program (sqlserver, oracle, postgresql...);
 - I8: Deploy the parsing SDK to parse the data according to the data format specified by the customer;
 - I9: Users customize docking method, note required.
9. For special requirements, please contact us and note in the order.