



Industrial Strength Fume Arms



Industrial strength in capturing:

- **WELDING FUMES**
- **GRINDING DUSTS**
- **DRY DUSTS**
- **SOLDERING DUSTS**
- **POWDERS**

and many more...



Industrial Strength Fume Arms

Applications:

Welding • Grinding • Polishing • Cutting
Soldering • Chemical Fumes and many more!

Features:

- industrial strength
- versatile design
- smooth tube construction
- external joints and supports
- hood and tube grab handles
- air diverter in the hood
- standard damper

Benefits:

- long lasting life time
- user-friendly operation
- higher airflow performance
- easy to adjust and maintain
- simple positioning
- increased capture velocity
- damper with-in the price



All External Joints and Supports

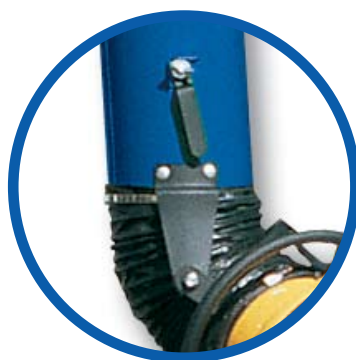

Standard Damper



**Air Diverter and Grab Handle
all around the Hood**

Oskar's Fume Arms are the most versatile, durable and economical method for capturing air impurities at their source. The construction of steel tubes, flexible hose at joints and external cast aluminium joints allow the arm to be positioned where needed. Oskar's Fume arms come in diameters of 75, 100, 125, 160 and 200mm and lengths up to 4m.

All of Oskar's Fume Arm can be easily equipped with a light kit or larger hood diameters. Oskar's Fume Arms can be easily used with Oskar's Sliding Suction Rails, Extension Booms, Fans and Modular Units. For more specific information on Oskar's Fume Arms contact your local Oskar Representative or visit our web site at www.oskarairproducts.com

1 HOOD JOINT
Hood easy to move forward, backward and sideways. All external adjustments. Flexible hose with gear clamps

2 MIDDLE JOINT
All external adjustments. Flexible hose with gear clamps.

3 SOCKET JOINT
Rotating swivel with safety stop. All external adjustments. Flexible hose with gear clamps.

Industrial Strength Fume Arms

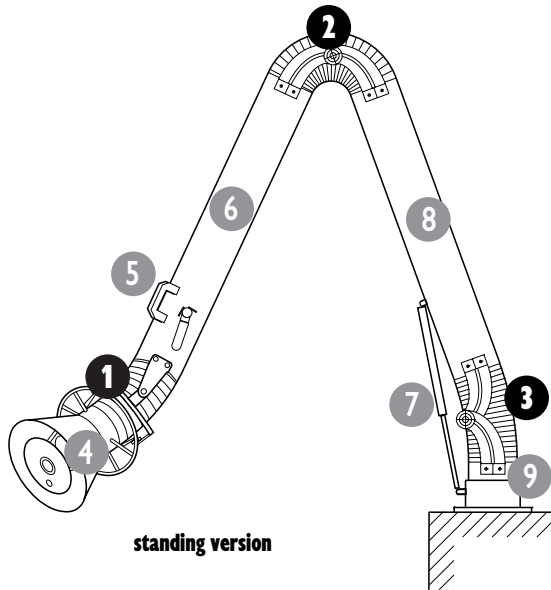

standing version

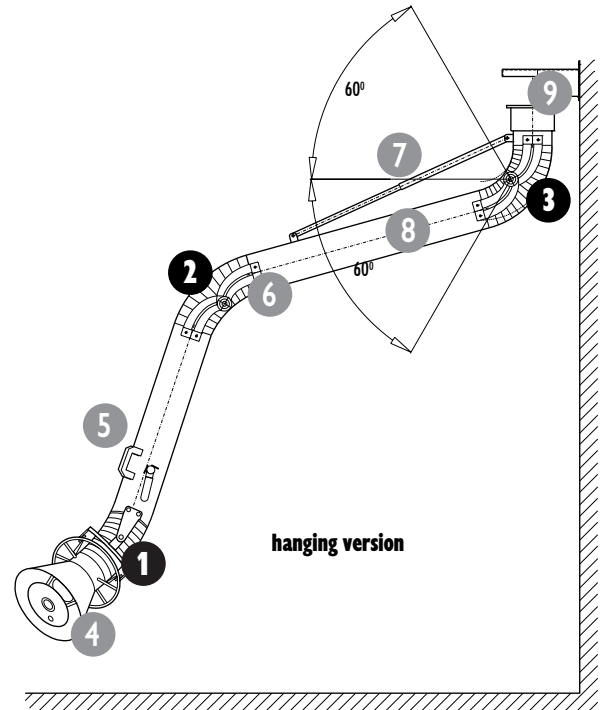

hanging version

- 4** Aluminium hood (powder coated) with surrounding grab handle, ready to be fitted with optional light kit.
- 5** Additional tube grab handle.
- 6** Smooth steel tube (powder coated) with standard damper.
- 7** Support spring or gas shock on the outside on both versions.

- 8** Smooth steel tube (powder coated).
- 9** Swivel base with predrilled mounting holes

Comparison

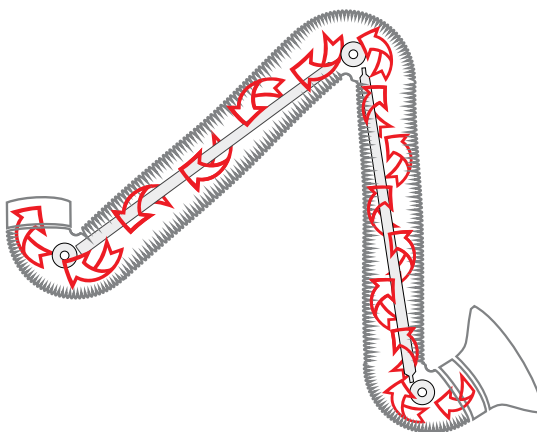

Non Oskar fume arm - internal components

- non smooth airflow
- higher static pressure
- hard to clean
- building on joint and components

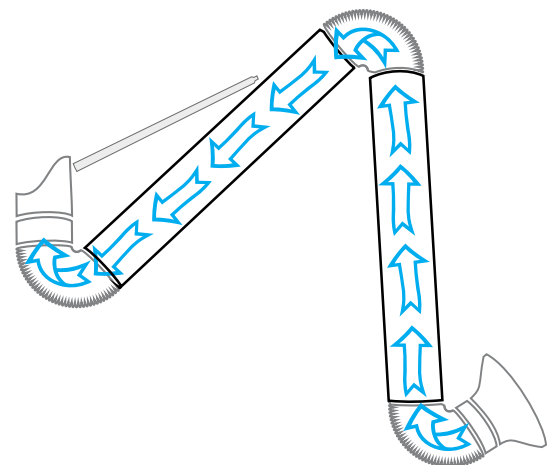

Oskar fume arm - external components

- smooth airflow
- lower static pressure
- quick cleaning
- minimal build up

Technical Data

Static Pressure & Air Flow



Model	Arm reach [feet]/[m]	Arm diameter [inch]/[mm]	Hood diameters [inch]/[mm]
0710	3 / 1,0	3 / 76	4 / 160
0715	5 / 1,5	3 / 76	4 / 160
1015	5 / 1,5	4 / 100	8 / 200
1020	7 / 2,0	4 / 100	8 / 200
1025	8 / 2,5	4 / 100	8 / 200
1220	7 / 2,0	5 / 125	12 / 315
1225	8 / 2,5	5 / 125	10 / 315
1230	10 / 3,0	5 / 125	12 / 315
1620	7 / 2,0	6 / 160	12 (14) / 315 (350)
1630	10 / 3,0	6 / 160	12 (14) / 315 (350)
1640	14 / 4,0	6 / 160	12 (14) / 315 (350)
2020	7 / 2,0	8 / 200	14 (20) / 350 (500)
2030	10 / 3,0	8 / 200	14 (20) / 350 (500)
2040	14 / 4,0	8 / 200	14 (20) / 350 (500)

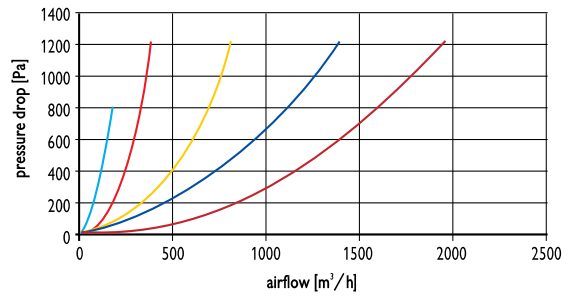
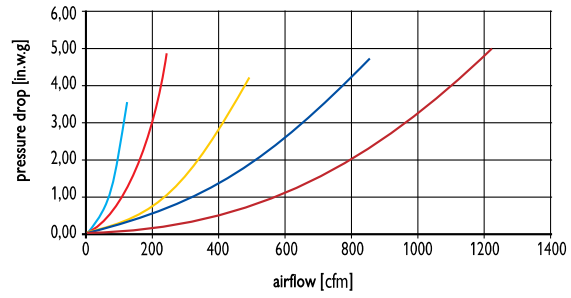

Standard wall mounting brackets

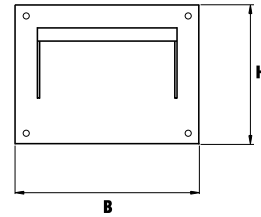
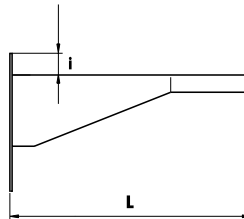
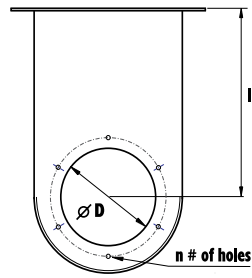
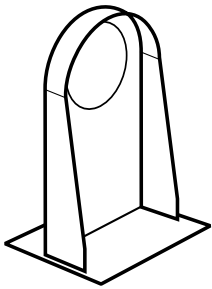

Bracket type Ø [in.]/[mm]	n	Ø D [in.]/[mm]	I [in.]/[mm]	L [in.]/[mm]	i [in.]/[mm]	B [in.]/[mm]	H [in.]/[mm]	weight lb/[kg]	Part number
3"/76	4	3.15 / 80	3.54 / 90	6.69 / 170	-	5.43 / 138	3.94 / 100	1 / 0.45	P07010001
4"/100	4	3.94 / 100	3.94 / 100	7.48 / 190	-	6.30 / 160	3.94 / 100	1 / 0.45	P07010002
5"/125	6	4.92 / 125	6.02 / 153	9.96 / 253	1.38 / 35	9.45 / 240	6.30 / 160	8 / 3.6	P07010003
6"/160	6	6.30 / 160	10.00 / 254	14.72 / 374	1.38 / 35	9.84 / 250	6.50 / 165	8 / 3.6	P07010004
8"/200	8	8.07 / 205	12.36 / 314	18.11 / 460	1.57 / 40	12.99 / 330	9.84 / 250	14 / 6.3	P07010005

Complementary Products



Boom



Sliding Suction Rail



Exhaust Fans



Modular Filter



Welding Bench



Giant



Roll-Out



Bag Filter

Industrial Strength Fume Arms