

## MD 569

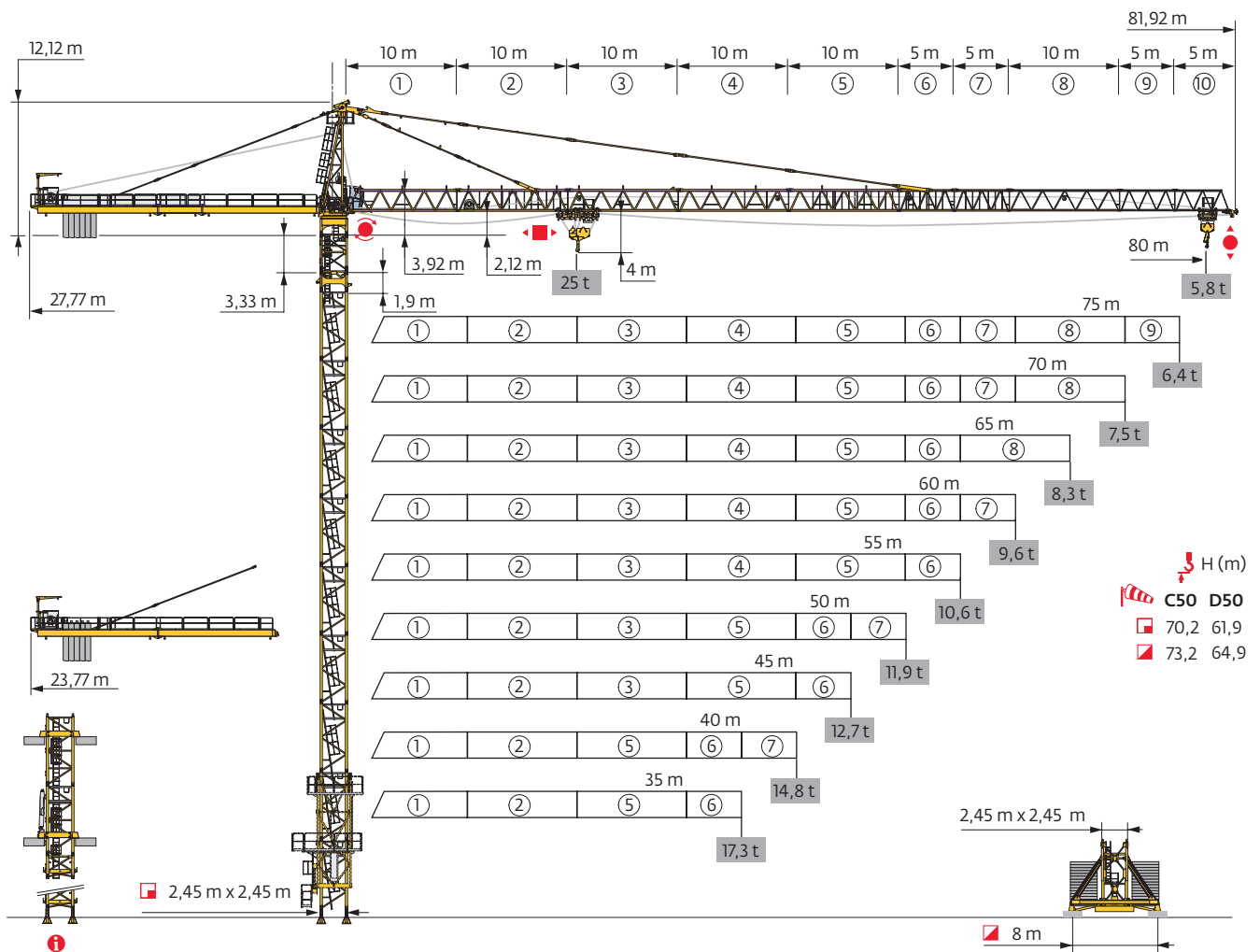

Potain Plus



Power Control

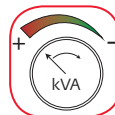

Top Site

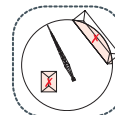

Top Tracing 3

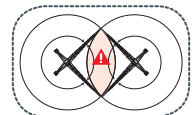

Mât - Réactions / Mast - Reaktionskräfte / Mast - Reactions / Mástil - Reacciones / Torre - Reazioni  
Tramo - Reacções / Реакция опор мачты

□ 2,45 m - P 800B - C50											
ΔΔΔΔ (m)	35	40	45	50	55	60	65	70	75	80	
↓ (m)	70,2	68,6	68,6	68,6	68,6	68,6	66,9	66,9	63,6	63,6	
↓/P↑ (m)	70,2	68,6	68,6	68,6	68,6	68,6	66,9	66,9	63,6	63,6	
	3,33 m	1	1	1	1	1	1	1	1	1	
	1,9 m	1	1	1	1	1	1	1	1	1	
	3,33 m	2	0	0	0	0	1	1	0	0	
	5 m	12	13	13	13	13	13	12	12	12	
F2 (t)	●	243	240	245	241	238	240	235	233	227	229
	■	392	370	357	375	368	377	358	368	328	329
F3 (t)	●	155	152	166	149	157	145	152	136	135	136
	■	316	294	278	295	287	295	274	283	244	243
↓ (m) D50	60,2	60,2	61,9	60,2	60,2	60,2	60,2	58,6	58,6	58,6	
↓/P↑ (m) D50	60,2	60,2	61,9	60,2	60,2	60,2	60,2	58,6	58,6	58,6	

□ 2,45 m - Y 800B - □ - C50											
ΔΔΔΔ (m)	35	40	45	50	55	60	65	70	75	80	
↓ (m)	73,2	73,2	69,9	71,5	69,9	69,9	69,9	69,9	66,5	64,9	
↓/P↑ (m)	73,2	73,2	69,9	71,5	69,9	69,9	69,9	69,9	66,5	64,9	
	3,33 m	1	1	1	1	1	1	1	1	1	
	1,9 m	1	1	1	1	1	1	1	1	1	
	3,33 m	1	1	0	2	0	0	0	2	0	
	5 m	12	12	12	11	12	12	12	12	10	11
F1 (t)	●	148	150	133	144	134	137	135	137	133	129
	■	198	200	170	194	176	181	177	183	167	154
↓ (m) D50	63,2	63,2	64,9	63,2	63,2	63,2	63,2	61,5	61,5	61,5	
↓/P↑ (m) D50	63,2	63,2	64,9	63,2	63,2	63,2	63,2	61,5	61,5	61,5	

**i** Accès motorisés types Cab-IN et TCL : compositions de mâture, de lest de base et réactions adaptées. / Motorisierter Zugang vom Typ Cab-IN und TCL: Mastzusammensetzung, Grundballast und Reaktionskräfte sind angepasst. / Motorized accesses of Cab-IN and TCL types: Adapted mast composition, base ballast and reactions. / Acceso a cabina con elevador tipo Cab-IN (interno) y tipo TCL (externo): Adaptación de composición de mástil, lastre de base y reacciones. / Accessi motorizzati di tipo Cab-IN e TCL: composizioni elementi torre, zavorre di base e reazioni aggiornate. / Acessos motorizados tipo Cab-IN e TCL: composições de coluna, lastro da base e reacções adaptadas. / Лифты Cab-IN и TCL для подъема крановщиков: адаптированная композиция мачты, базовый балласт и нагрузки.

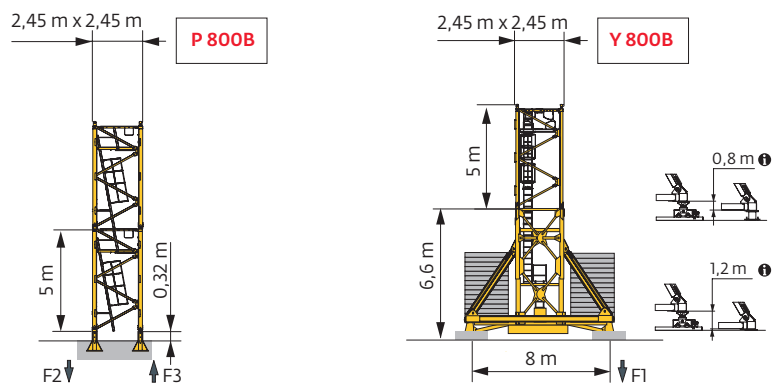

Ancrages / Verankerungen / Anchorages / Anclajes / Ancoraggi  
Ancoragem / нкрепа



Lest de base / Grundballast / Base ballast / Lastre de base / Zavorra di base  
 Lastro da base / Базовый Балласт

 <span style="color: red;">(t) / <math>\square</math> 2,45 m - Y 800B - <math>\square</math> - C50</span>										
AVAIL (m)	35	40	45	50	55	60	65	70	75	80
73,2	168	168								
71,5	156	156		144						
69,9	132	132	120	132	120	120	120	120		
66,5	108	108	96	108	96	108	96	96	108	
64,9	96	96	96	84	96	84	84	84	96	96
59,9	84	84	84	72	84	72	72	72	84	84
54,9	72	72	72	72	72	72	72	72	72	72
49,9	72	72	72	72	72	72	72	72	72	72
44,9	72	72	72	72	72	72	72	72	72	72
39,9	72	72	72	72	72	72	72	72	72	72
34,9	72	72	72	72	72	72	72	72	72	72
29,9	72	72	72	72	72	72	72	72	72	72
24,9	72	72	72	72	72	72	72	72	72	72

Courbes de charges / Lastkurven / Load curves / Curvas de cargas / Curve di carico / Curvas de carga / Кривые нагрузок



↖↗ (m)		17	20	25	27	30	35	37	40	45	47	50	55	57	60	65	67	70	72	75	77	80	m
↖↗	↖↗ 25 t	↖↗											↖↗										
↖↗	↖↗↔↖↗ 12,5 t	↖↗											↖↗										
80	3,9 → 20,8 3,9 → 21,4	25	25	20,2	18,4	16,2	13,3	12,5	12,5	11	10,5	9,7	8,7	8,3	7,8	7	6,8	6,4	6,2	5,9	5,7	5,4	t
75	3,9 → 21 3,9 → 21,7	25	25	20,4	18,6	16,4	13,6	12,7	12,5	11,2	10,6	9,9	8,8	8,4	7,9	7,2	6,9	6,5	6,3	6	t		
70	3,9 → 22,1 3,9 → 22,9	25	25	21,6	19,8	17,4	14,5	13,5	12,5	11,8	11,2	10,4	9,3	9	8,4	7,6	7,4	7	t				
65	3,9 → 22,1 3,9 → 23	25	25	21,7	19,8	17,5	14,6	13,6	12,5	11,9	11,3	10,5	9,4	9	8,5	7,7	t						
60	3,9 → 23 3,9 → 24	25	25	22,7	20,8	18,5	15,3	14,3	13	12,4	11,8	11	9,8	9,4	8,9	t							
55	3,9 → 23,1 3,9 → 24,2	25	25	22,8	20,9	18,4	15,3	14,3	13	12,5	11,9	11	9,9	t									
50	3,9 → 23,2 3,9 → 24,3	25	25	22,9	20,9	18,5	15,4	14,4	13,1	12,5	11,9	11,1	t										
45	3,9 → 23,1 3,9 → 24,4	25	25	22,8	20,9	18,5	15,4	14,4	13,1	12,5	t												
40	3,9 → 23,3 3,9 → 24,6	25	25	23,1	21,1	18,6	15,5	14,5	13,2	t													
35	3,9 → 23,3 3,9 → 24,7	25	25	23	21	18,6	15,5	t															

$↖↗ = ↖↗ - 1,45 \text{ t max.}$



↖↗ (m)		17	20	25	27	30	35	37	40	45	47	50	55	57	60	65	67	70	72	75	77	80	m
↖↗	↖↗ 25 t	↖↗											↖↗										
↖↗	↖↗↔↖↗ 12,5 t	↖↗											↖↗										
80	2,7 → 21,4 2,7 → 22	25	25	20,9	19,1	16,9	14,1	13,2	12,3	10,7	10,1	9,4	8,3	7,9	7,4	6,7	6,4	6	5,8	5,5	5,3	5	t
75	2,7 → 21,5 2,7 → 22,2	25	25	21	19,3	17	14,2	13,3	12,4	10,8	10,2	9,5	8,4	8	7,5	6,8	6,5	6,2	5,9	5,6	t		
70	2,7 → 22,5 2,7 → 23,3	25	25	21,9	20,1	17,8	14,9	14	12,8	11,4	10,8	10,1	9	8,6	8,1	7,3	7	6,6	6,4	6	t		
65	2,7 → 22,5 2,7 → 23,4	25	25	22,2	20,4	18	15,1	14,1	12,9	11,5	10,9	10,1	9	8,6	8,1	7,3	t						
60	2,7 → 23,5 2,7 → 24,5	25	25	23,3	21,3	18,9	15,8	14,8	13,5	12	11,4	10,6	9,5	9,1	8,5	t							
55	2,7 → 23,5 2,7 → 24,6	25	25	24,4	22,4	20	16,8	15,7	14,4	12,5	12,2	11,4	10,2	9,8	9,2	t							
50	2,7 → 23,6 2,7 → 24,8	25	25	23,3	21,5	19	15,9	14,9	13,6	12,1	11,5	10,7	t										
45	2,7 → 23,5 2,7 → 24,8	25	25	24,6	22,6	20,1	16,9	15,9	14,5	12,6	12,3	11,5	10,3	t									
40	2,7 → 23,7 2,7 → 25,1	25	25	23,4	21,4	19	15,9	14,9	13,6	12,1	t												
35	2,7 → 23,7 2,7 → 25,1	25	25	24,8	22,8	20,3	17	16	14,6	12,7	t												

$↖↗ = ↖↗ - 0,35 \text{ t max.}$

Poids de flèche & lest de contre-flèche / Auslegergewicht & Gegenauslegerballast / Jib weight & counter-jib ballast / Peso de flecha y lastre de contra-flecha/Peso del braccio & zavorra di contro-braccio/Peso da lança & lastro da contra lança/Вес стрелы и балласт контр-стрелы



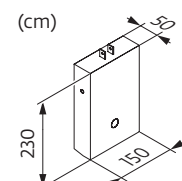
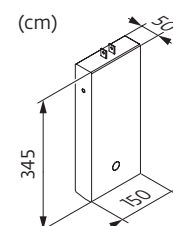

↖↗	↖↗ (kg) (+/- 5%)		100 LVF			150 LVF GH		
	↖↗↔↖↗	↖↗↔↖↗	6000 kg	4000 kg	↖↗ (kg)	6000 kg	4000 kg	↖↗ (kg)
80 m	25635	26125	6	0	36000	4	2	32000
75 m	25135	25625	5	1	34000	3	3	30000
70 m	24585	25075	5	1	34000	2	4	28000
65 m	23500	23990	5	0	30000	1	5	26000
60 m	23195	23685	5	0	30000	2	3	24000
55 m	22110	22600	4	1	28000	1	4	22000
50 m	20430	20920	5	0	30000	2	3	24000
45 m	19350	19840	4	1	28000	2	3	24000
40 m	17505	17995	2	3	24000	1	3	18000
35 m	16425	16915	1	4	22000	0	4	16000

CBC - 6000 kg











CBD - 4000 kg

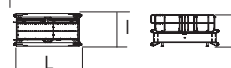
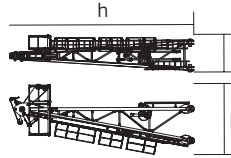
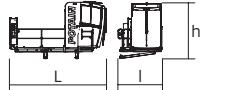
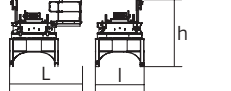
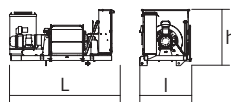
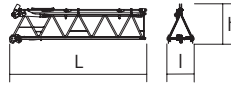
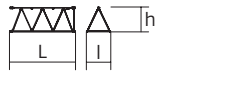
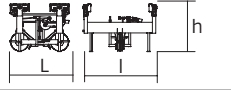

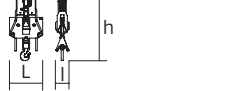
Encombrenment et poids / Abmessungen und Gewicht / Dimensions and weight / Dimensiones y peso / Ingombro e peso  
dimensões e pesos / габаритные размеры и вес

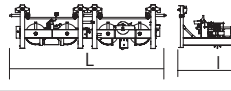
Partie tournante / Drehender Kranteil / Slewing crane part / Parte giratoria  
Parte rotante / Parte rotativa / Поворотная часть :  80 m -  -  -  100 LVF

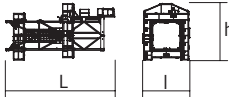

Partie tournante / Drehender Kranteil / Slewing crane part Parte giratoria / Parte rotante / Parte rotativa Поворотная часть		L (m)	I (m)	h (m)	kg (+/- 5%)	
Contre-flèche / Gegenausleger Counter-jib / Contra-flecha Controbraccio / Contra-lança Контр-стрела		11,69	4,13	1,96	6490	
		4,2	2,02	1,96	1980	
		11,04	3,57	2,07	4925	
Porte-flèche / Auslegerträger Cathead / Porta-flecha Cuspide / Suporte de lança Оголовок		3,54	1,99	9,86	8265	
Cabine / Kabine Cab / Cabina Cabina / Cabina Кабина		Ultra View	5	2,5	2,77	1875
Pivot / Krankopf Towerhead / Pivote Portaralla / Pivot Секция поворотной части		∇2,45 m	3,7	2,9	3,87	11190
Treuil de levage (+ câble) / Hubwerk (+ Seil) Hoisting winch (+ rope) / Mecanismo de elevación (+ cabo) Argano di sollevamento (+ fune) Guincho de elevação (+ cabo) Подъемная лебедка (+ канатом)		100 LVF 150 LVF GH	3,43 4,27	1,6 1,93	1,75 1,9	4090 9230
Elément de flèche / Auslegerement Jib section / Elemento de flecha Elemento di braccio / Elemento de lança Секция стрелы		①	10,36	1,9	2,54	5075
		② 10 DVF	10,33	1,9	2,34	4735
		③	10,23	1,9	2,4	3005
		④	10,23	1,9	2,33	2765
		⑤	10,23	1,9	2,32	2835
Elément de flèche / Auslegerement Jib section / Elemento de flecha Elemento di braccio / Elemento de lança Секция стрелы		⑥	5,32	1,9	2,25	1720
		⑦	5,24	1,9	2,04	1080
		⑨	5,18	1,9	1,97	550
		⑩	5,08	1,9	1,97	500
Chariot / Laufkatze Trolley / Carrello Carro / Carro-distribuidor Тележка		 25 t	1,8	2,26	1,44	760
Moufle / Hubflasche Pulley block / Aparejo Bozzello / Cadernal Полиспаст		 25 t	1,18	0,44	2,39	850
Chariot / Laufkatze Trolley / Carrello Carro / Carro-distribuidor Тележка		 25 t	4,1	2,19	1,16	1195
Moufle / Hubflasche Pulley block / Aparejo Bozzello / Cadernal Полиспаст		 25 t	1,83	0,34	2,34	905

Рүлбне / Kranturm / Crane tower Mástil / Torre / Torre Башня крана	L (m)	I (m)	h (m)	kg (+/- 5%)	
T 851 	$\surd$ 2,45 m	11,18	4,84	5,8	15750
K 849/K 849 Mât de télescopage / Teleskopiermast Telescoping mast / Tramo de telescopaje Elemento di telescopaggio / Tramo de Telescopagem Мачта для телескопирования	$\surd$ 2,45 m	2,14	3,25	2,5	2985
KR 849A KRMT 849A KR 849C KRMT 849C	$\surd$ 2,45 m	5,23 5,23 3,57 3,57	2,53 2,55 2,55 2,55	2,5 2,53 2,53 2,53	4290 4090 3195 3205
Pieds de scellement / VerankerungsfüÙe Fixing angles / Pie de empotramiento Montante da annegare / Angulos fixadores анкера	P 800B	0,75	0,75	1,28	465
Mât-châssis / Grundmasteinheit Basic mast unit / Tramo-chassis Elemento base / Tramo-chassis Мачта для крепления к шасси	Y 800B	6,03	2,93	2,93	8620
Haubans / Mastabstützungen Struts / Tornapuntas Puntoni / Escoras Растяжка	Y 800B	5,51	0,5	0,45	1110
1/2 Longeron / 1/2 Längsträger 1/2 Side member / 1/2 Larguero 1/2 Longherone / 1/2 Longarina 1/2 боковина	Y 800B	5,68	1,24	0,73	1520
Longeron / Längsträger Side member / Larguero Longherone / Longarina боковина	Y 800B	12	1,24	0,73	3050
Support lest / Ballastträger Ballast support / Soporte de lastre Supporto zavorra / Suporte de lastro Опора балласта	Y 800B	3,75	0,37	0,92	1085
Traverse de châssis / Unterwagentraverse Chassis beam / Traviesa chasis Traversa carro / Travessa chasis балка шасси	Y 800B	8,7	0,83	0,74	2240

Mécanismes / Triebwerke / Mechanisms / Mecanismos / Meccanismi  
 Mecanismos / Механизмы

400 V - 50 Hz													ch - PS hp	kW	
	<b>100 LVF 63 Optima</b>	m/min	30	38,5	52,5	69	78	15	19,5	27	35,5	39	100	75	726 m
		t	12,5	9,4	6,3	3,1	2,2	25	18,8	12,5	6,3	5,4			
	<b>150 LVF 63 GH Optima</b>	m/min	45,5	57,5	79	130	192	23	29	40,5	69	96	150	110	1200 m
		t	12,5	9,4	6,3	3,1	0,9	25	18,8	12,5	6,3	3,1			
	<b>10 DVF 10 Optima</b>	m/min	0 → 66 (25 t) 0 → 80 (20 t) 0 → 100 (12,5 t) 0 → 110 (6,3 t)									10	7,4		
	<b>RVF 173 Optima+</b>	tr/min U/min rpm	0 → 0,8									3 x 10	3 x 7,5		

100 LVF 63 Optima

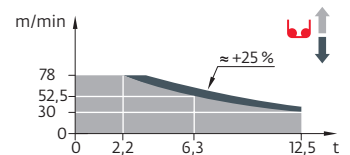

	<b>IEC 60204-32</b>	<b>kVA</b>
400 V (+10% -10%) 50 Hz		100 LVF : 117 → 77 kVA 150 LVF GH : 157 → 97 kVA

	<b>FR</b>	<b>DE</b>	<b>EN</b>	<b>ES</b>	<b>IT</b>	<b>PT</b>	<b>RU</b>
	Profil de vent suivant EN 14439 C50-D50	Windbedingungen gemäss EN 14439 C50-D50	Wind conditions according to EN 14439 C50-D50	Conformidad de los condiciones de viento EN 14439 C50-D50	Condizioni del vento secondo EN 14439 C50-D50	Perfil de vento conforme EN 14439 C50-D50	Ветровой режим в соответствии с EN 14439 C50-D50
	Équipements standards	Standardausrüstungen	Standard equipment	Equipamiento de serie	Equipaggiamento standard	Equipamento de série	Стандартное оборудование
	Équipements optionnels	Sonderausrüstungen	Options	Equipamiento opcional	Equipaggiamento in opzione	Equipamento opcional	Дополнительное оборудование (опция)
	Fonction Potain Plus : Courbes de charges Plus	Funktion Potain Plus: Plus-Lastkurven	Potain Plus function: Plus load curves	Función Potain Plus: Diagrama de cargas Plus	Funzione Potain Plus: Curve di carico Plus	Função Potain Plus: Diagrama de cargas Plus	Функция контроля мощности Potain Plus: Диаграммы грузоподъемности Plus
	Hauteurs sous crochet associées aux courbes de charges Plus	Hakenhöhen mit Plus-Lastkurven	Hook heights with Plus load curves	Altura bajo gancho, usando el diagrama de cargas Plus	Altezze sotto gancio con curve di carico Plus	Altura livre, utilizando o diagrama de cargas Plus	Высота под крюком для диаграмм грузоподъемности Plus
	Réactions en service	Reaktionskräfte in Betrieb	Reactions in service	Reacciones en servicio	Reazioni in servizio	Reacções em serviço	Реакция при работе
	Réactions hors service	Reaktionskräfte außer Betrieb	Reactions out of service	Reacciones fuera de servicio	Reazioni fuori servizio	Reacções fora de serviço	Реакция в покое
	Poids total du lest	Ballast-Gesamtgewicht	Total ballast weight	Peso total del lastre	Peso totale della zavorra	Peso total do lastro	Общий вес балласта
	Poids de flèche	Auslegergewicht	Jib weight	Peso de flecha	Peso del braccio	Peso da lança	вес стрелы
	Camion 13,4 m	Lkw 13,4 m	Lorry 13,4 m	Camión 13,4 m	Camión 13,4 m	Camião 13,4 m	Rрузовой автомобиль 13,4 м
	Conteneur High Cube 40', et/ou Flat Rack 20'	Container High Cube 40', und/oder Flat Rack 20'	Container High Cube 40', and/or Flat Rack 20'	Contenedor High Cube 40', y/o Flat Rack 20'	Container High Cube 40', e/o Flat Rack 20'	Contentor High Cube 40', e/ou Flat Rack 20'	40-футовый контейнер повышенной вместимости High Cube, и/или 20-футовая открытая платформа Flat Rack
	Levage	Heben	Hoisting	Elevación	Sollevamento	Elevação	Подъем
	Distribution	Katzfahren	Trolleying	Distribución	Distribuzione	Distribuição	Перемещение по стреле
	Orientation	Schwenken	Slewing	Orientación	Rotazione	Rotação	Поворот
	Translation	Kranfahren	Travelling	Traslación	Traslazione	Translação	Перемещение крана
	Puissance requise	Erforderliche Leistung	Required power	Potencia Necesaria	Potenza richiesta	Potência Necessária	Потребляемая мощность
	Fonction Power Control : vitesses treuils adaptées à la puissance disponible	Funktion Power Control: Geschwindigkeiten der Triebwerke werden an die verfügbare Leistung angepasst	Power Control Function: winch speeds adapted to the available power	Función Power Control: marchas de los cabrestantes adaptadas a la potencia disponible	Funzione Power Control: velocità degli argani adattate alla potenza disponibile	Função Power Control: velocidades de guincho adaptadas à potência disponível	Функция контроля мощности Power Control: регулировка скорости лебедок в зависимости от доступной мощности
	Nous consulter	Auf Anfrage	Consult us	Consultarnos	Consultateci	Consultar-nos	Проконсультируйтесь у нас
	Document commercial non contractuel. Pour toute information technique se référer à la notice correspondante.	Unverbindliches Vertriebsdokument. Für technische Informationen, siehe die entsprechenden Anweisungen.	This commercial document is not legally binding. For any technical information, please refer to the corresponding instructions.	Documento comercial no contractual. Para cualquier información técnica, ver la noticia correspondiente.	Documento commerciale non vincolante, per tutte le informazioni tecniche fare riferimento al catalogo istruzioni.	Documento comercial não contratual. Para qualquer informação técnica complementar consultar as respectivas instruções.	Этот коммерческий документ не является юридически обязательным. Для получения технической информации, см. соответствующие инструкции.

