

RITE-LINK SERIES

Features and Benefits

Right Sized Conveying

The **CAMCO Rite-Link Conveyor** is a thin-profile, preassembled, precision link system offering maintenance free accuracy and durability for industrial conveying applications.

Precision positioning requiring higher precision or speed than roller chain can provide

Material conveying (industrial or medical): for example, narrow cleat or bucket conveyor for constant speed applications. The conveyor can be mounted for either over/under or carousel operation

NEW



Features:

Assembly

- Fully designed, assembled and tested for your application
- Can be used in an over/under or carousel configuration

Size

- Slim, compact design with narrow links accommodates oversized tooling
- Easy to integrate
- Servo-friendly for flexible indexing with CAMCO RSD rotary servo drive

Accuracy

- Precision motion from the trusted industry leader
- More accurate and stable than roller chain

Operation

- High operation speeds
- No lubrication needed
- Energy efficient
- Cost Effective

Maximum Load	Units	75RL...	115RL...	150RL...
Max Load per Link	kg [lbm]		4 [8.82]	
Max Overhung Load per Link	N-m [in-lb]		0,57 [5]	

* shipping/clearance dimensions

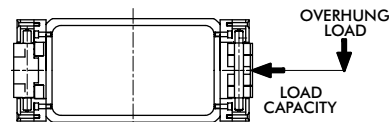
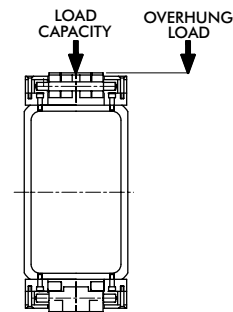

RITE-LINK SERIES

Link Dimensions

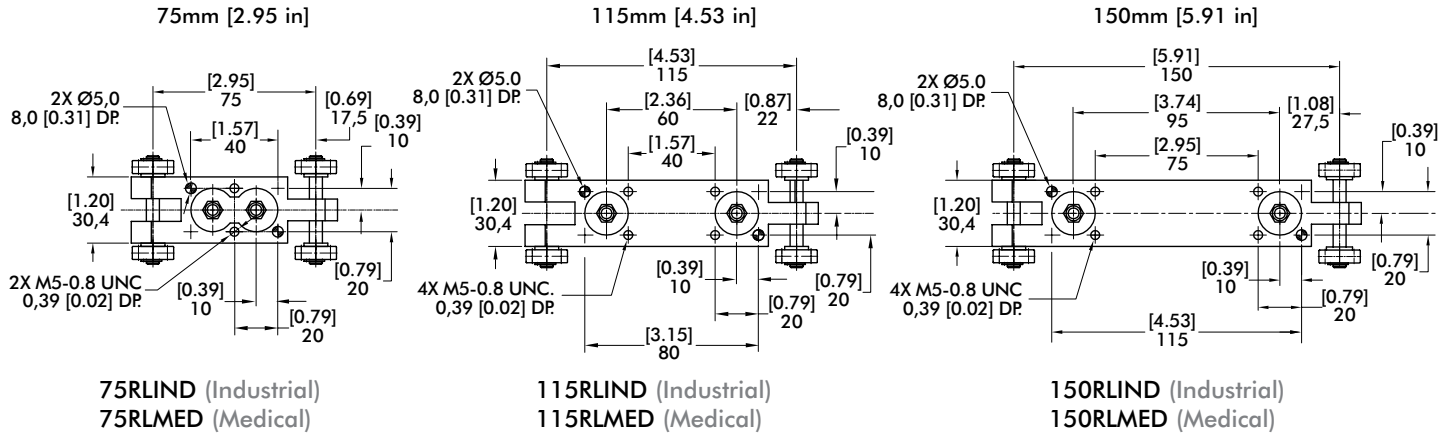

Standard Centers Dimensions

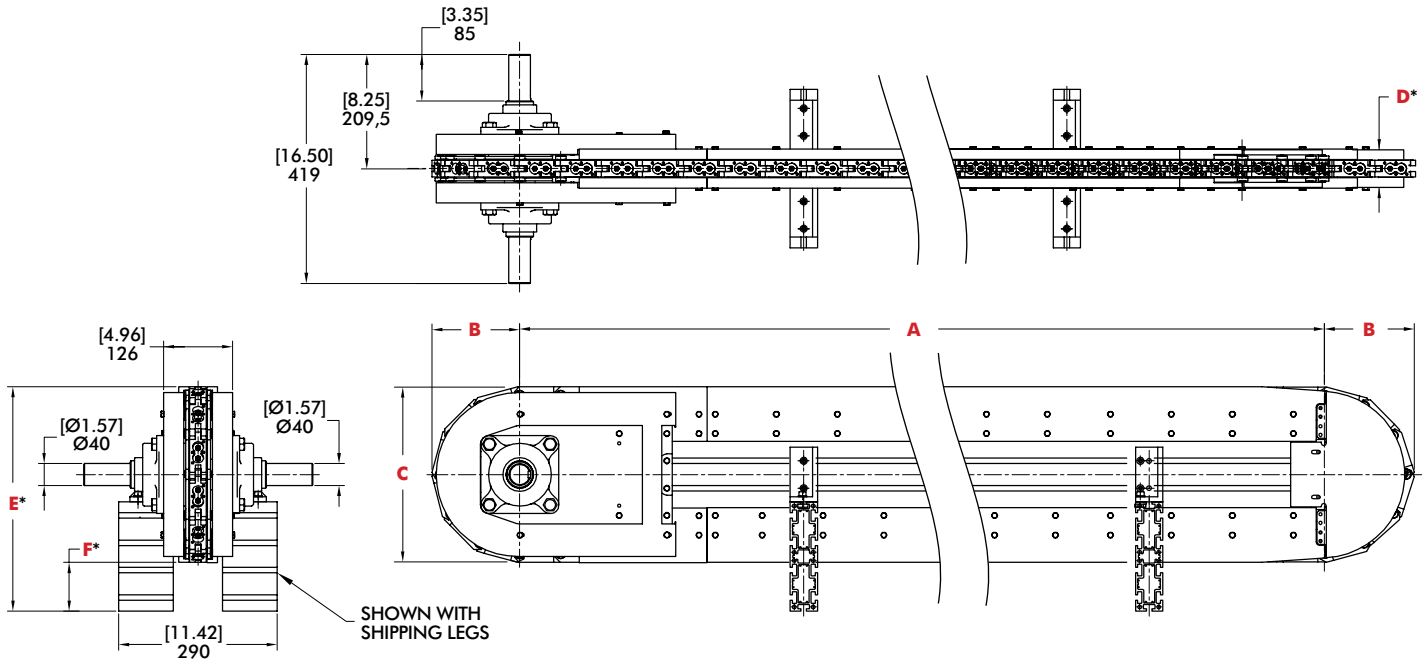

Technical Information

Dimensions	Units	75RL...	115RL...	150RL...
A Standard Center Distances				
Option 1	m [ft]	1,2 [3.94]	1,38 [4.53]	1,2 [3.94]
Option 2		2,1 [6.89]	2,30 [7.55]	2,1 [6.89]
Option 3		3 [9.84]	3,22 [10.56]	3 [9.84]
Option 4		3,9 [12.80]	4,14 [13.58]	3,9 [12.80]
Option 5		4,8 [15.75]	5,06 [16.60]	4,8 [15.75]
B	mm [in]	162,5 [6.40]	166 [6.54]	162,5 [6.40]
C	mm [in]	320 [12.60]	332 [13.07]	332 [13.07]
D*	mm [in]	78,1 [3.07]	78,1 [3.07]	78,1 [3.07]
E*	mm [in]	411 [16.18]	466,2 [18.35]	416 [16.38]
F*	mm [in]	89 [3.50]	133,8 [5.27]	84 [3.31]

* shipping/clearance dimensions