

Serie Standard

Modello PH



Chiusino diam. 400 mm con chiusura rapida a leva (standard)
Valvola sfiato PVC

Lid diam. 400 mm with clamp closure (standard)
Pressure PVC Valve

Finitura esterna satinata
Finitura interna BA

External satin polished
Internal BA polished

Gabbia di protezione in acciaio zincato (inox su richiesta)

Galvanised cage (inox on request)

Tubazione di scarico con gomito a 90° e fondo bombato
Shape bottom with drawing pipe with a 90° bend

Guida-forche per transpallet o carrello elevatore

Palletised base with fork slot

Caratteristiche tecniche

- Cage de protection en acier galvanisé (inox sur demande)
- Base palettisée avec guide fourches
- Finition extérieure satinée et finition intérieure BA
- Soudage TIG. Nettoyage mécanique de soudures
- Trappe diam. 400mm avec fermeture rapide à levier (standard)
- Soupape en PVC
- Fond bombé avec bride centrale et tuyau avec une coude à 90°
- Vanne de vidange à boule ou papillon max DN 50 (2")
- Schutzkäfig aus verzinktem Stahl (Edelstahl optional)
- Palettierte Basis mit Gabelführung
- Oberfläche innen BA, außen satiniert, Domdeckel elektroliert
- Robotergeschweißte Nähte im WIG Verfahren, Schweißnähte gebeizt und passiviert
- Deckel Durchmesser 400mm mit Schnellverschluss mit Hebel (Standard)
- Entlüftungsventil aus PVC
- Krumm Boden mit Flansch und Rohre mit Ellbogen zu 90°
- Ausladen mit Kugelhahn oder Scheibenhahn DN 50 (2")
- Jaula protectora de acero galvanizado (inox optional)
- Base pallet con guía-horquillas
- Acabado externo satinado y interno BA
- Soldadura TIG limpieza mecánica de las soldaduras
- Tapa diam. 400mm con cierre rapido de palanca (estandard)
- Valvula de aire de PVC
- Fondo combado con brida central y tubo de descarga con codo a 90°
- Valvula de descarga esférica o mariposa max. DN 50 (2")

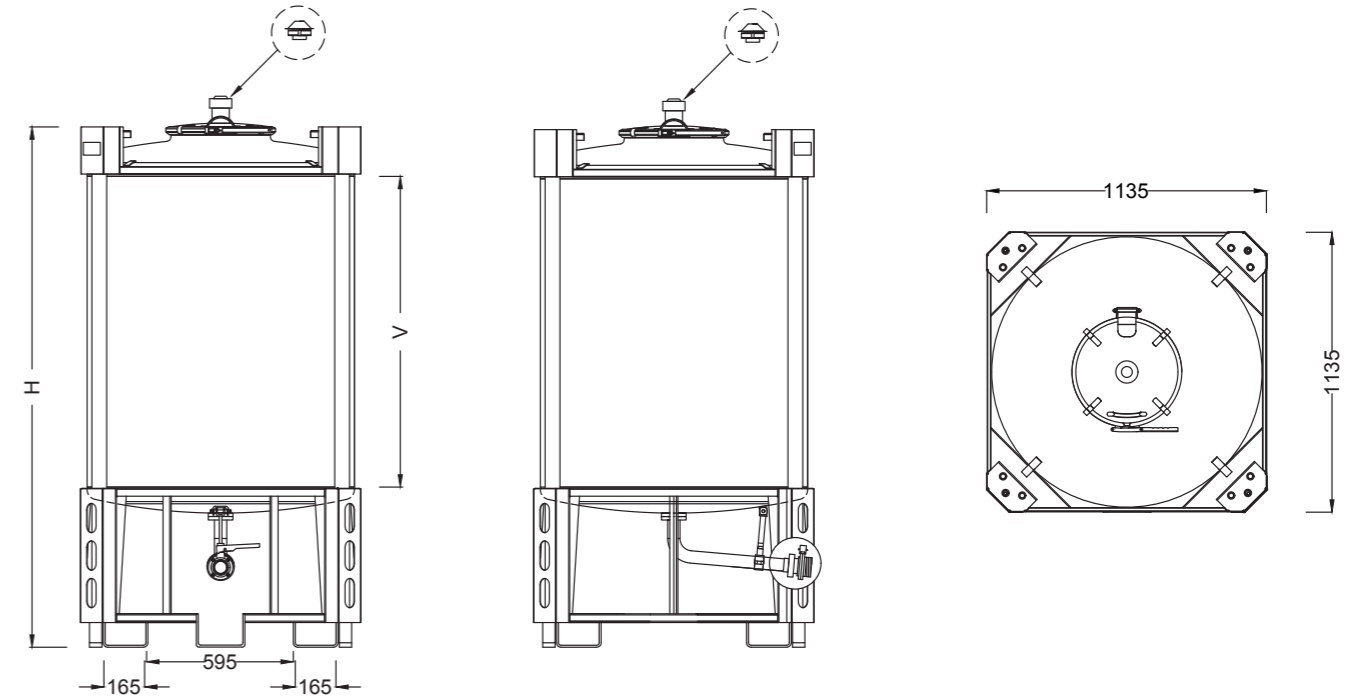

AISI 304
AISI 316 (optional)

Spessore 1,5mm
2,0mm (optional)
Thickness 1,5mm
2,0mm (optional)

Saldature TIG
Decapate e spazzolate
TIG Welding
Pickled and passivated

Impilamento max:
2 pieni sovrapposti
Stacking max:
2 full

Modello	Capacità lt.	Ø serbatoio	H mm	V mm	Peso kg
PH750	740	1080	1475	625	125
PH1000	1000	1080	1785	910	140
PH1250	1309	1080	2060	1250	157
PH1500	1537	1080	2310	1500	168
---	---	---	---	---	---

particolari - specifics - détails - Detail - particolare



accessori - accessories - accessoires - zubehör - accesorios

