

MECBO



ATB 24L

TRUCK MOUNTED PUMP

Truck
Distributor boom
Pumping group

4 axles
MB24L/100-BZ
P4 / P6



PULSAR SYSTEM

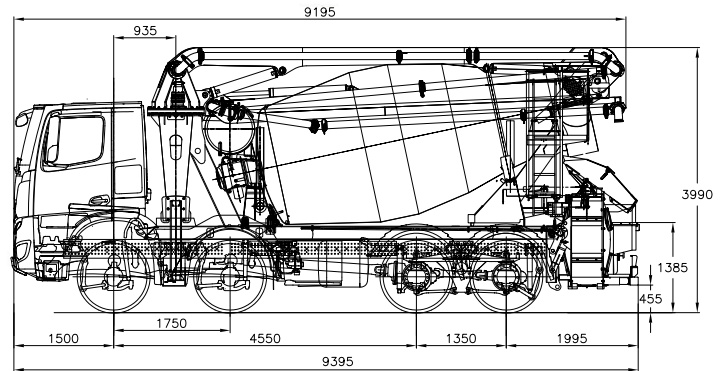
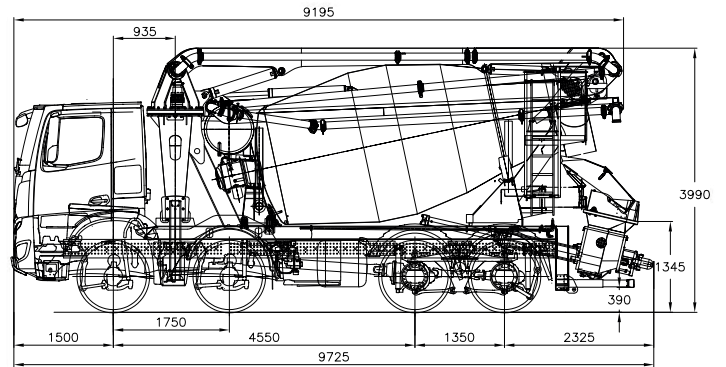
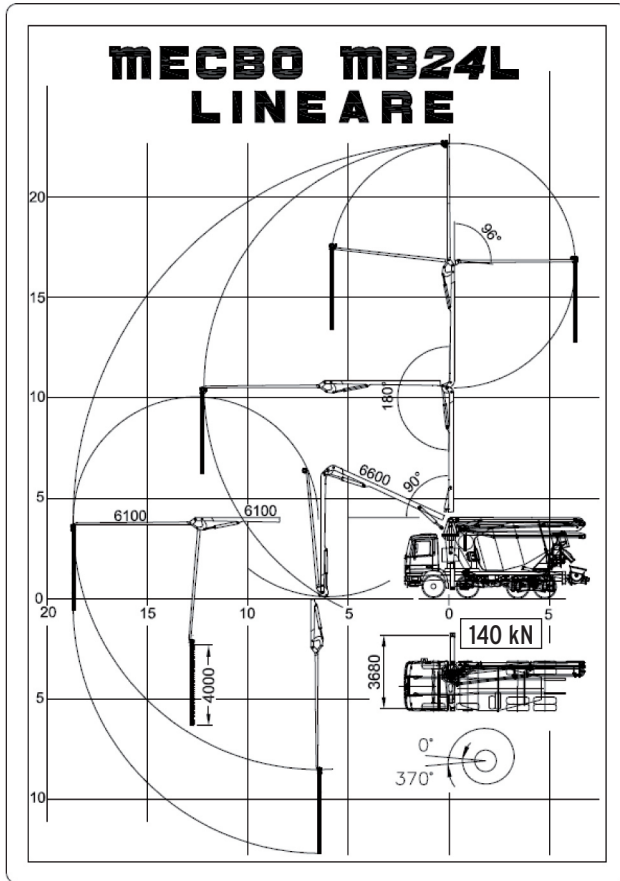

BRACCIO DISTRIBUTORE DISTRIBUTOR BOOM FLECHE DISTRIBUTEUR VERTEILERMAST		GRUPPO POMPANTE PUMPING GROUP GROUPE DE POMPAGE PUMPENGRUPPE			
Diametro tubazione Pipeline diameter Diamètre de la tuyauterie Förderleitung Durchmesser	100 mm	Pompa tipo Pump type Pompe type Pumpeart	P4.40	P6.60	ROTOR RS60
Raggio orizzontale Horizontal reach Portée horizontale Horizontalablenkung	19 m	Diametro dei cilindri Cylinders diameter Diamètre cylindres Zylindersdurchmesser	180 mm	200 mm	/
Altezza massima Max. vertical reach Portée verticale Max. Höhe	24 m	Corsa Stroke Course Schlaganfall	1000 mm	1000 mm	/
Min. altezza apertura Min. openig height Min. hauteur d'ouverture Min. Öffnungshöhe	6.3 m	Diametro uscita Outlet diameter Diamètre sortie Austrittsdurchmesser	125 mm (5" ½)	125 mm (5" ½)	125 mm (5" ½)
Numero di sezioni Sections Number Nombre de sections Anzahl der Abschnitte	3 Z	Volume tramoggia Hopper capacity Capacité trémie Kapazität des Trichters	570 l	610 l	350 l
Rotazione torretta Slewing range Rotation de la tourelle Turmdrehung	370°	Pressione in uscita Outlet pressure Pression sortie Betondruck	50 bar	50 bar	26 bar
Pressione oleodinamica Hydraulic pressure Pression hydraulique Hydraulikdruck	300 bar	Portata calcestruzzo Concrete output Débit béton Beton Fördermenge	40 m³/h	60 m³/h	60 m³/h
Tensione imp. Elettrico Electrical voltage Tension électrique Spannung des Elektr. System	12-24V	Peso gruppo pompante Pumping Group weight Poids groupe pompage Pumpegewicht	1200 kg	1500 kg	2200 kg

*Inclusi nella fornitura pompa acqua, serbatoio acqua, telecomando, radiocomando, sistema di stabilità "Full Range" (EN 12001:2012).
Supplied with water pump and tank, remote control by cable, wireless radio control, stability system "Full Range" (EN 12001:2012).
Inclus pompe à eau, réservoir eau, télécommande, radiocommande, système de stabilité "Full Range" (EN 12001:2012).
Inbegriffen Wasserpumpe, Wassertank, Kabel-Fernbedienung, Radio-Fernbedienung, Stabilitätssystem "Full Range" (EN 12001:2012).*

OPTIONAL – EN OPTION FAKULTATIV
VIBRATORE - VIBRATOR VIBRATEUR - VIBRATOR
POMPA ACQUA – WATER PUMP POMPE A EAU - WASSERPUMPE
TUBAZIONE E ACCESSORI PIPELINES AND ACCESSORIES TUYAUTERIES ET ACCESSOIRES ROHRLEITUNG UND ZUBEHÖRE
SISTEMA STABILITA' "SINGLE SIDE RANGE" (EN 12001:2012) STABILITY SYSTEM "SINGLE SIDE RANGE" (EN 12001:2012) SYSTEME DE STABILITE' "SINGLE SIDE RANGE" (EN 12001:2012) STABILITÄTSSYSTEM "SINGLE SIDE RANGE" (EN 12001:2012)
LUBRIFICAZIONE AUTOMATICA AUTOMATIC LUBRICATION LUBRIFICATION AUTOMATIQUE AUTOMATISCHE SCHMIERUNG

I presenti dati tecnici hanno valore indicativo. Con l'evolversi della tecnologia, i dati esposti potranno subire modifiche senza preavviso. Le richieste tecniche specifiche debbono essere sempre accettate dalla nostra Direzione con conferma scritta. The present technical data have indicative value. Owing to the technology development, all above mentioned details maybe changed without any notice. All specific technical request must be always accepted from our Management by written confirmation.