



80.2



EFFER
RAISE THE VALUE

80.2

Effer has created the 80.2 for the operators that need a light but multipurpose tool for their work. Thanks to the electronic management system **Progress 2.0**, it is possible to set up this model to **work with basket or winch**. Through the remote control, the 80.2 manages the stabilizers feet on the ground, and it is equipped with an **automatic system to slow down the rotation at the end of stroke** to avoid load swing. With Progress 2.0, the **performance is always optimized in accordance with booms geometry** and you can use **the Virtual Shield function** to avoid collisions with the truck cabin.

80.2 is an Effer light range crane: **the quality of materials and the design** of Effer's big and medium cranes features the 80.2 as well to ensure the best performance for any kind of application.



RECOMMENDED LOAD DIAGRAMS

1S

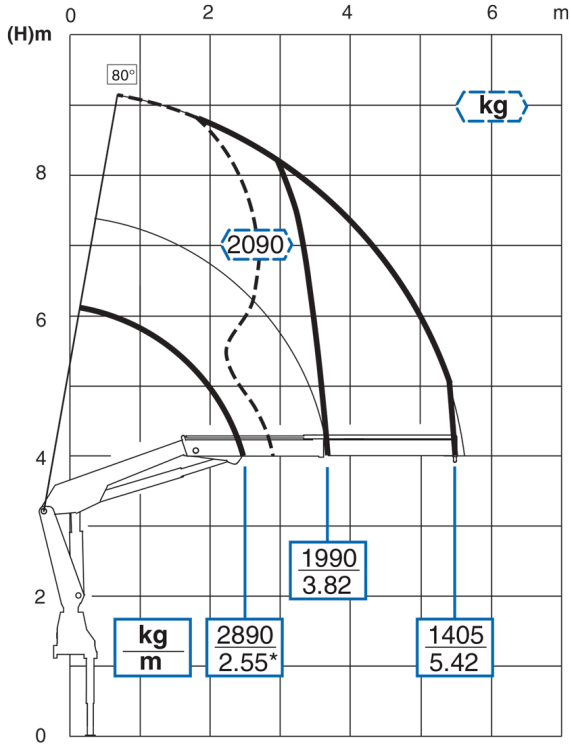

2S

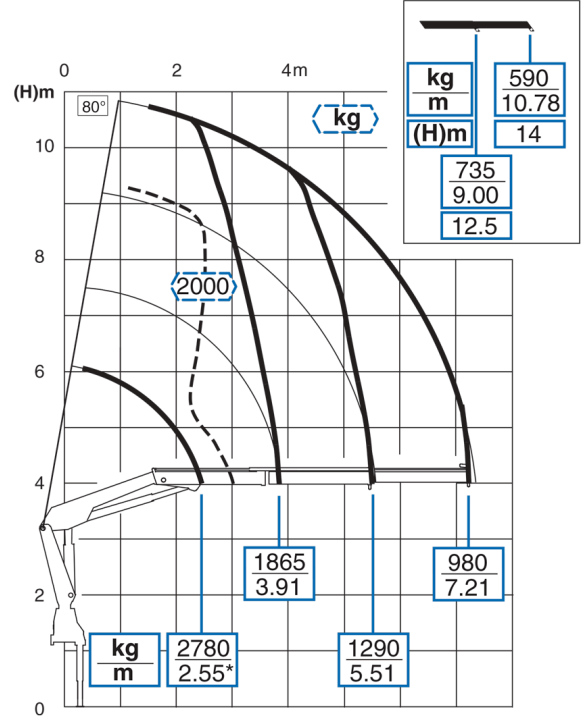

4S

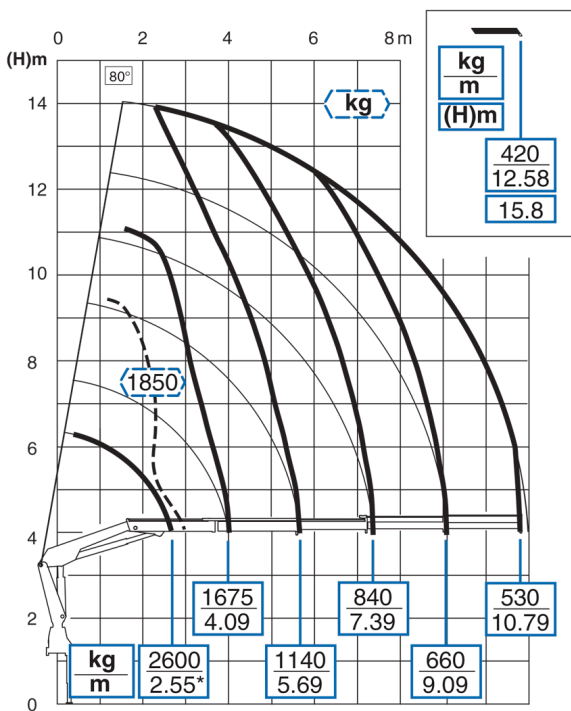

3S

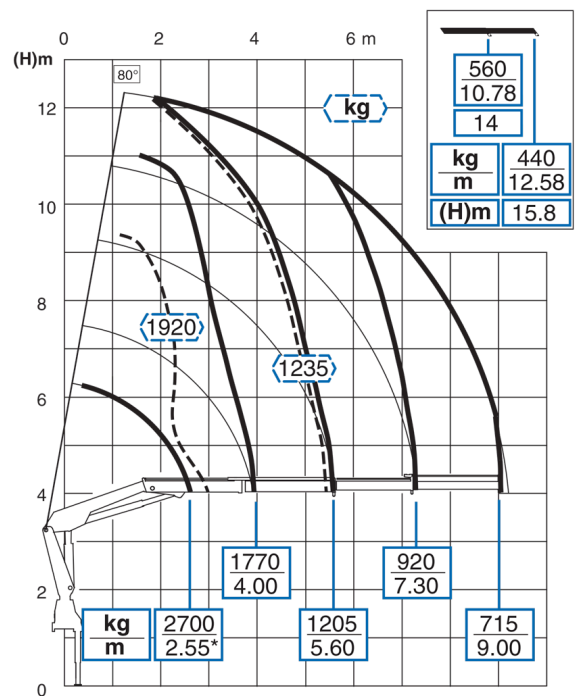

FOCUS ON THE PRODUCT

Some images may refer to models different from those described in this brochure

STRUCTURE OF THE CRANE

Hydraulic pipes design



The **pipes of cylinders are designed as multi-bend to fit the movements of the crane.** The wide inner section of pipes ensures the maximum operating speed of the oil, even in harsh climates, and prevents the oil from overheating, thus protecting the seals.

Hosereel or trestle works



Effer offers various solutions to connect the crane to the jib or other auxiliary equipment. To gather the hoses you can choose between compact hosereels or sturdy trestle works, depending on your needs.



Special steel



Effer's crane service life is **guaranteed by SSAB, the world leader in the production of high strength steels**. All models are manufactured using STRENX* steel sheets that are subject to strict quality controls. **In a Effer crane you can find up to 25 combinations of different thickness steels**, to ensure a weight/power ratio among the best in the world.

* Effer adheres to the exclusive "My Inner STRENX" program, the highest quality certification provided by SSAB.

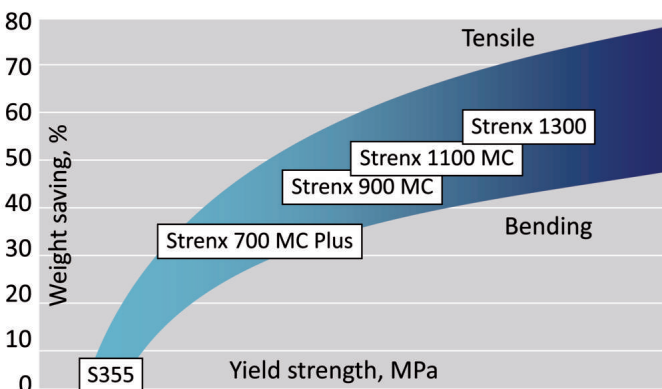

Rack rotation over 360°



The rack system by Effer allows **rotation angles up to 360° maintaining a stable power at all positions**, due to the low coefficient of friction between the moving parts. The adjuster of all backlashes and greasing points close together make it easier the maintenance of the rack.

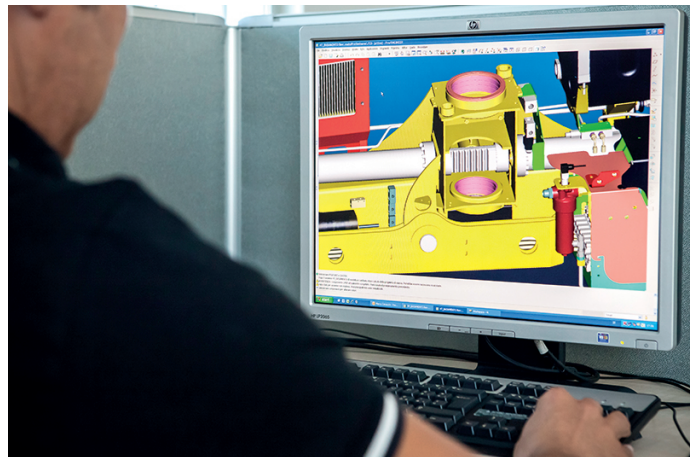

Boom section

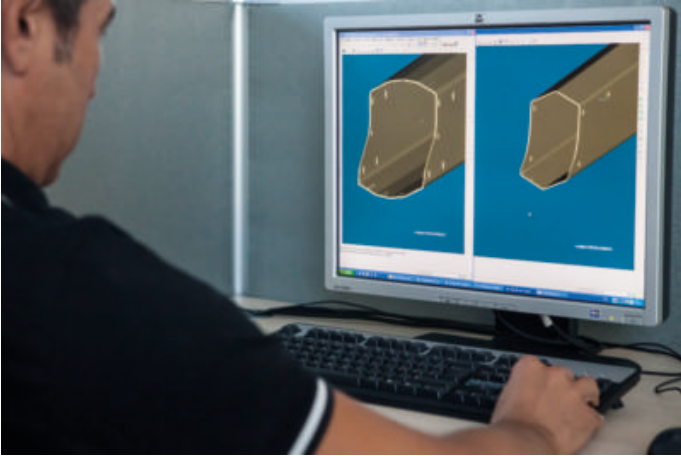

The second boom by Effer is designed with a hexagonal geometric or ten-sided section (Effer's patent), **optimized for each model to combine lightness and load capacity of the crane**. A single sheet metal is folded in several points and welded both inside and outside to ensure structural strength.

"Honeycomb" support structure



The link between the first and the second boom is designed to achieve the maximum rigidity in all the structure.



CARE FOR DETAILS

Quickfaster



To save time in assembling and disassembling the jib or other accessories, the Quickfaster connection **allows to connect all the pipes in a single movement and with utmost cleanliness.**

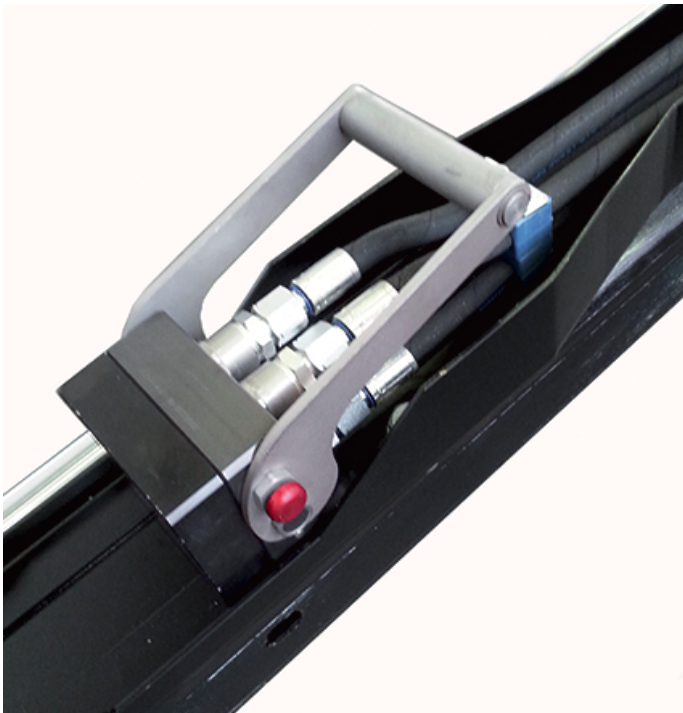

Swivelling stabilizers for maximum flexibility

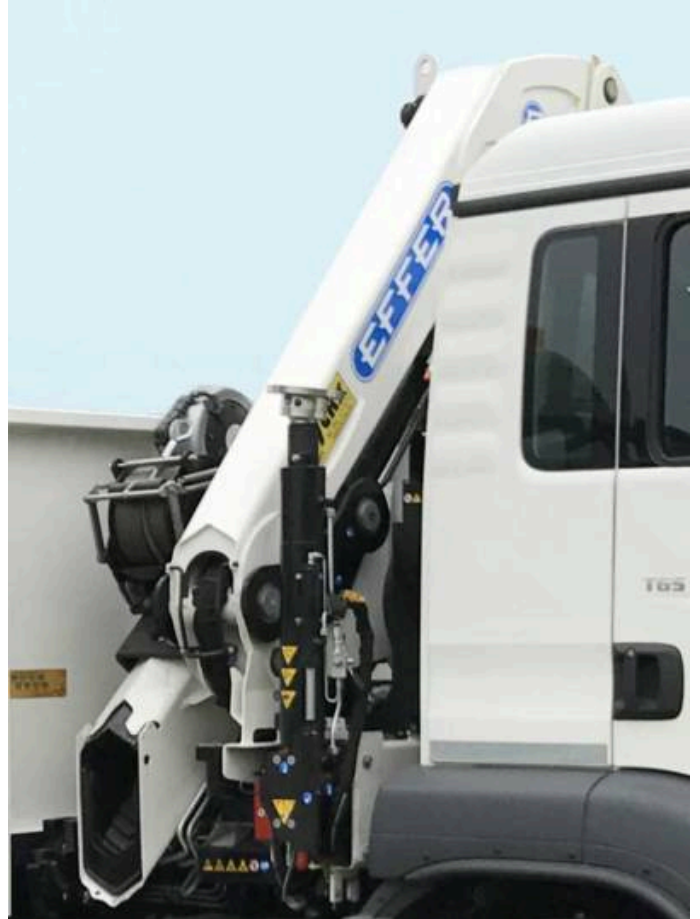

For correct installation of Effer cranes on all types of trucks, it is made available the manually operated swivelling stabilizer.

Protected electronic system, made to last over time



The cranes by Effer have electronic components with **IP 67 protection index to resist to water and dust**. The connections are watertight, and the sensors are placed in protected positions to **avoid accidental damage**.



100% “Made in Effer”

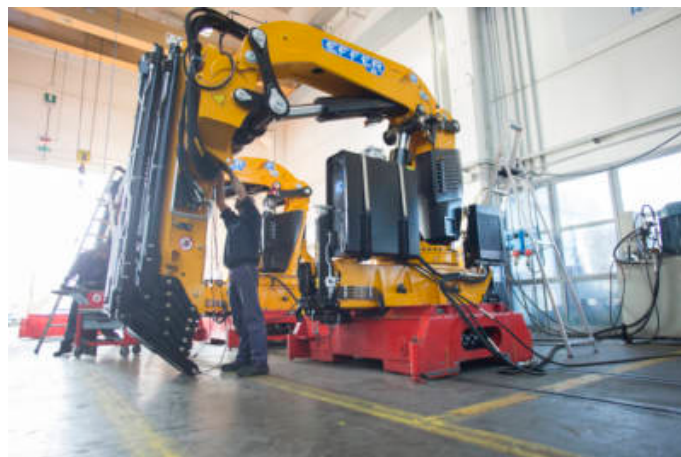

For over 50 years the production of cranes by Effer is completely carried out internally, from the design to the cutting of sheet metal, from the assembly and testing, up to shipping to the customer. **Each crane manufactured by Effer is unique, and since the very beginning arises with the full name name of his end customer**, since domestic production is on order.

Biodegradable oil



Panolin HLP SYNTH biodegradable oil, as well as having a **low impact on the environment**, does not degrade over time and always keeps unchanged its physical-chemical properties. Then **there will be no need to change it**, and the crane will ensure **stable performance even with drastic fluctuations in temperature**.

Hydraulic seals for maximum reliability over time



Effer guarantees **the maximum pressure tightness in the hydraulic system** using fittings with hydraulic front seals coming from the top of the range, the same used for the earth-moving machinery.

Double CAN-BUS network

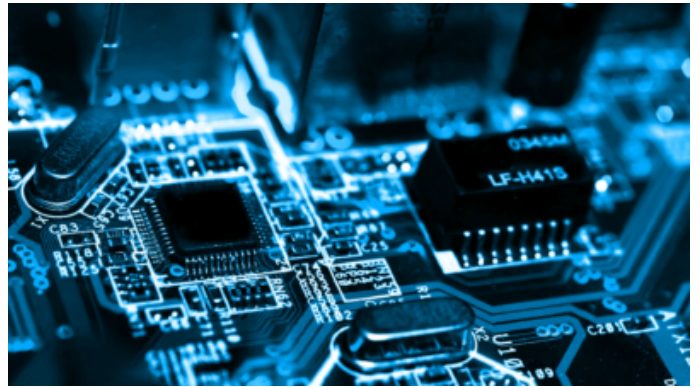

The two CAN-BUS networks work simultaneously and independently, and **guarantee reliable connections between the various electronic components** (control units, distributors, etc.). This technology allows you to quickly locate all possible electronic system faults.

LOAD HANDLING

Safety standards for cranes and basket



The PROGRESS 2.0 provides as standard the **safety performance C level** (EN12999) and on request **the basket safety performance D level** (EN 280:2001).

Headlights can be activated with the remote control



Working headlights (optional) allow you to operate effectively, day and night. **The PROGRESS 2.0 allows you to activate them directly from the remote control.**



Opening the extensions in symmetrical sequence



From first to last, all models by Effer have been designed with extensions that come out in perfect sequence, using sequence valves. Each cylinder is sized to its extension. In addition **the cylinders comes out alternately to keep the boom always perfectly straight.**

Simultaneous movements

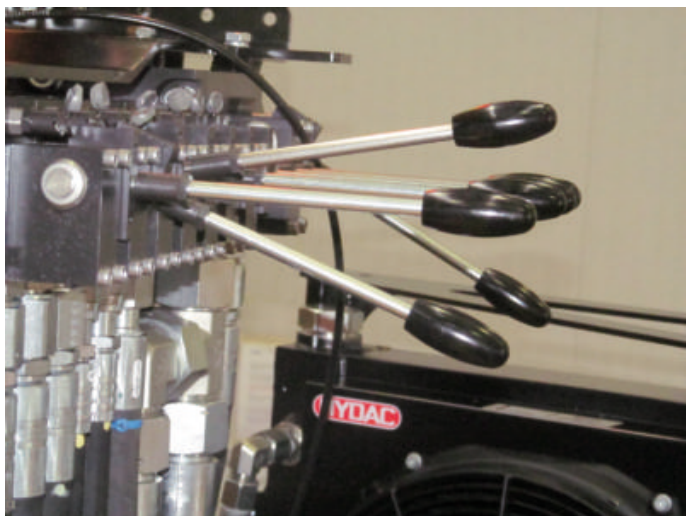

A crane by Effer handles many simultaneous movements intelligently distributing the oil in the hydraulic circuit according to the commands of the operator.

Virtual Shield – cab collision avoidance system – standing man

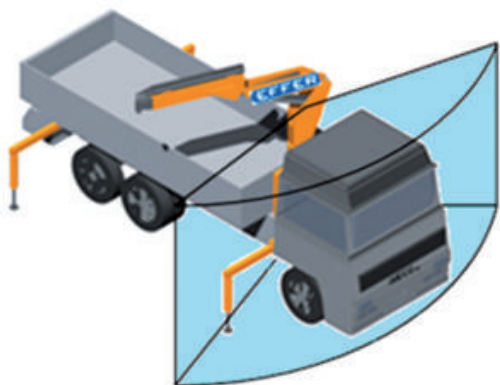

The movements of the crane are automatically stopped by Progress 2.0 that calculates a safe operating area, thus reducing the risk of accidental impact between the cab and the boom. It is also available the activation of a prohibited and defined workspace to protect the standing man (OVS Operators Virtual Shield).

Effer hydraulic power plant



The use of **hydraulic valves of the latest generation** lets you manage all the movements of the crane with gradual and progressive speed changes. The oil flow is optimized to **ensure always the right power and speed**.

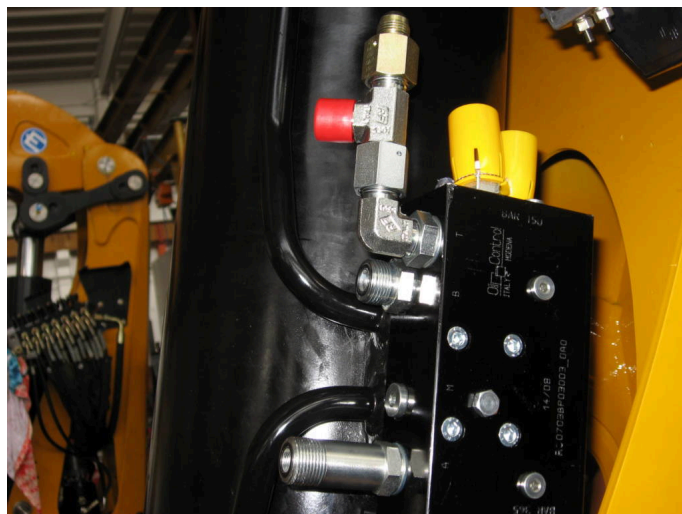

Unload now without wasting time

You can quickly unload the materials from the tipper body **without stabilizing the truck.**



WORK WITH WINCH

High speed anti-twisting ropes



Effer provides on its winches galvanized steel and lubricated anti-twisting ropes, already fitted with full thimble. The electronic components, such as the end limit, are in **protected locations to avoid accidental bumps**. To work rapidly, the ropes cables reach a **sliding speed up to 58 metres per minute**.



Load control at the winch



The PROGRESS 2.0 allows you to **handle the load of the crane at the winch by displaying the load values from remote controller** and making any and each movements simple and safe.



Disabling the winch via remote controller



The electronic control system allows disabling the use of the winch via the remote controller preventing unintentional switching to **maximize the safety** of the operator.



EASY MAINTENANCE

Easy trouble shooting



The wirings of Progress 2.0 are designed to **easily identify any faults**. CAN-BUS connections are grouped into specific points for easy access. Also **the signal is always unique with no bifurcation**, to minimize the time of trouble shooting, even without a PC.

Grease sprayer by Effer



Specifically designed to grease the extensions of the cranes manufactured by EFFER:

- It remarkably reduces the stick-slip of extensions.
- It is water, even salty, resistant.
- It protects the extensions from corrosion and rust.
- Compatible with all materials of guide and support shoes.
- It is equipped with adjustable nozzle to apply grease with maximum ease.

Maintenance always under control with PROGRESS 2.0



PROGRESS 2.0 stores crane operating cycles, and **points out the scheduled maintenance**. When necessary, you can enable the remote assistance by Effer (dealer or parent company). **PROGRESS 2.0 analyses the type of work done by the crane** according to the operating periods and types of movements performed, in order to optimize it or to detect any faults.



Recovery System



In case of faults, **PROGRESS 2.0** allows you to close the crane in emergency mode. In this way you can get the crane to the nearest Effer service point.

Intelligent oil filters



The filters of the hydraulic system by Effer indicate the clogging level, thus allowing you to **schedule maintenance and prevent damage to components** resulting from the use of dirty oil.

SOLUTIONS FOR STABILITY

4 work areas

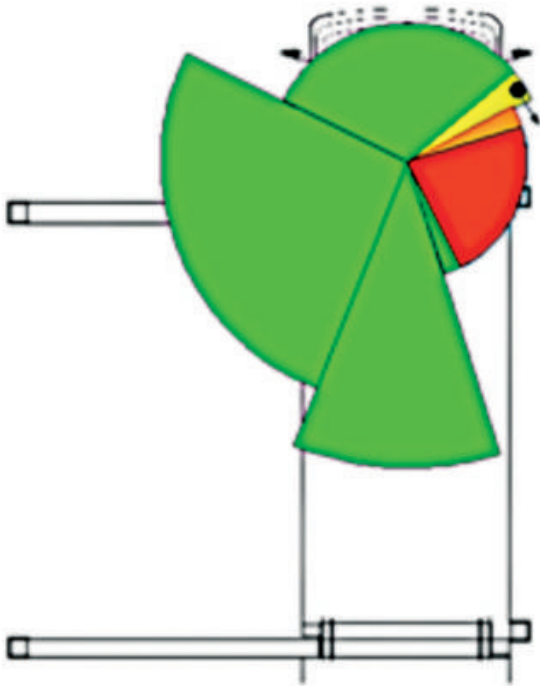

With PROGRESS 2.0 you can work with the **maximum load capacity** depending on the stability of the truck and the actual extension of the stabilizers, which is measured with encoder or magnetic sensors.

The operator has available **4 different operating areas**: front, rear, right and left.



Maximum productivity with rear installation

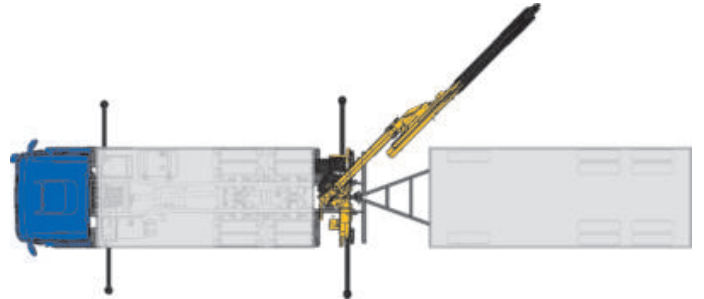

The Effer cranes give the best even in case of **rear installation**, for example when they are used in the fields of construction and loading and unloading of materials.



PERFORMANCE

DESCRIPTION	UNIT OF MEASURE	1S	2S	3S	4S
Max. hydraulic outreach	m	5,56	7,35	9,14	10,93
Max. lifting moment (+20°)	kgm	7615	7290	7080	6850
	kNm	75	75	70	67
Slewing arc	(°)	380			
Slewing Capacity- Max. slope	%	8,7			
Working Pressure	bar	345			
Max oil delivery	l/min	40			
Oil tank capacity	l	50			
Standard crane weight	kg	915	995	1070	1135

DIMENSIONS

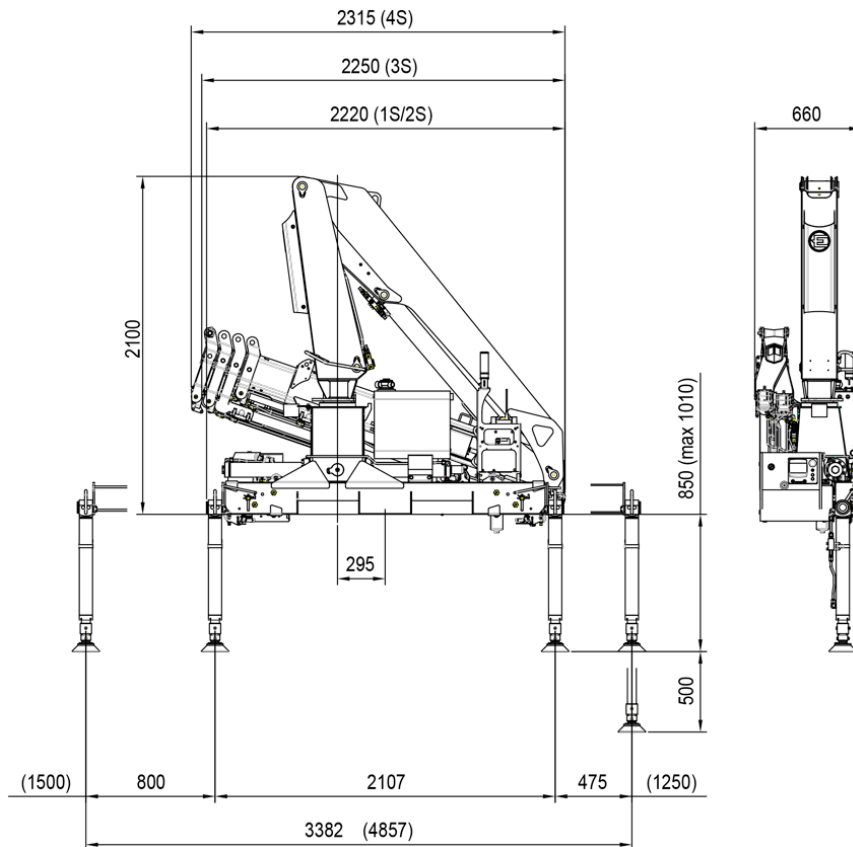

STANDARD



Hexagonal boom profile



Slewing by rack



Radio remote control with display



Stabilizers with manual outlet



Radio remote for stabilizers



Progress 2.0



Swing-up stabilizers, manually activated

OPTIONALS



Crane adjustment for crane equipped with basket



Radio remote with joystick



Winch



EFFER S.p.A.

Via IV Novembre, 12 | 40061 Minerbio (BO) – Italy
Tel. +39 051 4181211 | Fax. +39 051 4181491
S.P. 40 ex Vicinale Accetta Grande | 74010 Statte (TA) – Italy
Tel +39 099 4700191
www.effer.com | www.effermarine.com | info@effer.it



Created by **mysource** 