

# MT

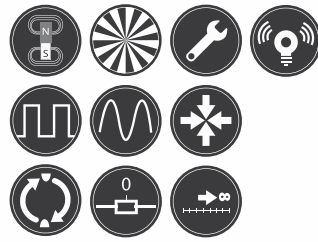

## MAGNETIC LINEAR ENCODER

Non contact magnetic linear encoder MT has measuring length up to 50 m.

The encoder is used to convert linear displacements of key machine components into electrical signals containing information about the value and direction of the displacement.

Encoder consists of metal based magnetic band MP, reading head and protective steel cover CV. The length of magnetic band could be up to 50 m. Encoder could be supplied with external zero signal actuator (magnet), which allows usage one of many reference marks made on magnetic band.

Zero signal actuator is not necessary in the case when the magnetic band with reference marks made according customer requirements (MP200Z) is used. Encoder also could be supplied with protective aluminium support SP (instead protective cover CV), which is mounted on machine for magnetic band protection.

The encoder has two versions of output signals:

- MT-F - Square-wave signals, with integrated subdividing electronics for interpolation.
- MT-AV - Sinusoidal signals, with amplitude approx. 1 Vpp, which require external subdividing electronics.

### MECHANICAL DATA

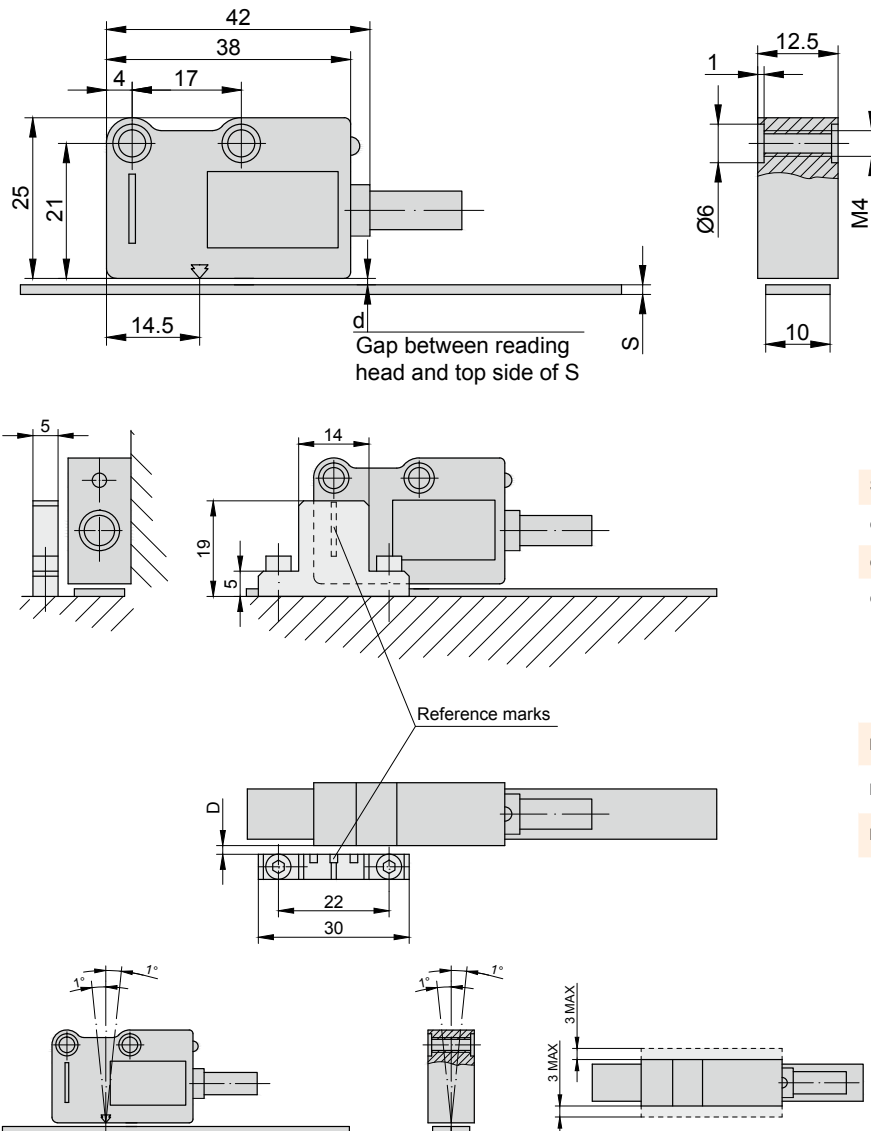

	MPx00	MPx00+CV	MPx00+SP
S(mm)	1.3	1.6	2.1
d(mm) MTP	0.1 ÷ 0.5	Not available	Not available
d(mm) MTM	0.3 ÷ 1.5	1.2 MAX	0.7 MAX
d(mm) MTH	0.3 ÷ 3.5	3.2 MAX	2.7 MAX

	D(MM)	
MTP (MP100)	Not available	Not available
MTM (MP200)	1.5 nom.	2.5 MAX
MTH (MP500)	1 nom.	2 MAX

## MT-F PARAMETERS

Measuring length (ML)	up to 50 m (max. 20 m with MP500)
Repeatability	±1 increment
Max. measuring frequency	300 kHz
Power supply	(5 ... 28) DC ±5%, V
Current consumption without load	60 mA max.
Current consumption with load	140 max. (with 5V and R=120Ω); 115 max (with 12V and R=1.2kΩ) ; 90 max (with 28V and R=1.2kΩ), mA
Phase shift between signals	90° ±5°
Protection (IEC 529)	IP67
Operating temperature	0...+50 °C
Storage temperature	20...+80 °C
Permissible humidity	100% non-condensing
Permissible vibration (55...2000 Hz)	300 m/s <sup>2</sup>
Permissible shock (11 ms)	1000 m/s <sup>2</sup>
Output signal shape	Square-wave TTL pulses
Output signals	6 - two main + one zero signal and their complementary
Output scheme	Line driver (TTL optional)
Weight of reading head	40 g
Standard cable length	2.0 m
Max. cable length of head	10.0 m
Max. cable length of encoder (2 m of head + adapter)	100.0 m
Electrical protections	from inversion of power supply polarity; from short circuit on output port

## READING HEAD MODIFICATIONS

READING HEAD	MTP-F	MTM-F	MTH-F
Reference (zero) signal *	Constant pitch every 1 mm (version C)	Constant pitch every 2 mm (version C) With external actuator (version E) Reference marks made on magnetic band according customer requirements (version Z)	Constant pitch every 5 mm (version C) With external actuator (version E) Reference marks made on magnetic band according customer requirements (version Z)
Pole pitch	1+1 mm	2+2 mm	5+5 mm
Accuracy **	±10 μm	±15 μm	±40 μm
Resolution (after x4 in CNC)	0,5; 1; 5; 10 μm	1; 5; 10; 25; 50; 100; 500; 1000 μm	1; 5; 10; 25; 50; 100 μm
Max. traversing speed	0.6 (MTP-F05); 1,2 (MTP-F10) m/s	1.2 (MTM-F10); 12 (MTM-F100) m/s	6 (MTH-F50); 12 (MTH-F100) m/s

\*Version C - without reference signal

Version E - zero signal is generated when external zero actuator acts to reference mark, which is made on magnetic band.

It is possible to use several actuators.

Version Z - zero signal is generated when reference mark is acted by actuator incorporated into reading head.

\*\*The smaller is the gap between reading head and magnetic band the better is accuracy of encoder.

Note: For heavy working conditions the special version of encoder is available (see data sheet for models CMT and PCMT).

**MT - AV**

Measuring length (ML)	up to 50 m (20 m with MP500)
Repeatability	±1 increment
Max. traversing speed	12 m/s
Power supply	(5 ... 28) DC ±5%, V
Current consumption without load	90 mA max.
Current consumption with load	110 mA max. (for 5V and R=120Ω)
∅Phase shift between signals	90° ±5°
Protection (IEC 529)	IP67
Operating temperature	0...+50 °C
Storage temperature	-20...+80 °C
Permissible humidity	100% non-condensing
Permissible vibration (10...2000 Hz)	300 m/s <sup>2</sup>
Permissible shock (11 ms)	1000 m/s <sup>2</sup>
Output signal shape	Sine-wave
Output signals	Two main + one zero (square-wave pulse)
Output scheme	Line driver; TTL
Weight of reading head	40 g
Standard cable length	2.0 m
Max. cable length of head	10.0 m
Max. cable length of encoder (2 m of head + adapter)	100.0 m
Electrical protections	from inversion of power supply polarity; from short circuit on output port

**READING HEAD MODIFICATIONS**

READING HEAD	MTP-AV	MTM-AV	MTH-AV
Reference (zero) signal	Constant pitch every 1 mm (version C)	Constant pitch every 2 mm (version C) With external actuator (version E) Reference marks made on magnetic band according customer requirements (version Z)	Constant pitch every 2 mm (version C) With external actuator (version E) Reference marks made on magnetic band according customer requirements (version Z)
Pole pitch	1+1 mm	2+2 mm	5+5 mm
Accuracy	±10 µm	±15 µm	±40 µm
Resolution (depending on external interpolator)	up to 0,1 µm	up to 0,5 µm	up to 1 µm
Max. measuring frequency	12 kHz	6 kHz	2.4 kHz

**MAGNETIC BAND**

Accuracy (at 20°C)	±30 (standard); ±15 (optional) µm/m
Width	10 mm
Thickness	1.3 mm
Length	50 m max. (20 m max.- for MP 500)
Thermal expansion coefficient	10,5 x 10 <sup>-6</sup> °C <sup>-1</sup> (at 20°C±0,1°C)
Bend radius	130 mm min.
Weight of magnetic band	65 g/m
Weight of protective cover	25 g/m
Operating temperature	0...+70 °C
Storage temperature	-20...+80 °C

## PROTECTIVE BAND CV

Stainless steel cover CV (width 10 mm, thickness 0,3 mm) for magnetic band MP protection is glued on magnetic band (excluding MP100)

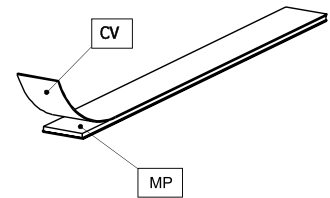

## PROTECTIVE SUPPORT SP

Aluminium protective support SP for magnetic band MP protection. Fixed on machine surface and holds magnetic band. It is not possible to use the support SP if the magnetic band is already covered by stainless steel band CV.

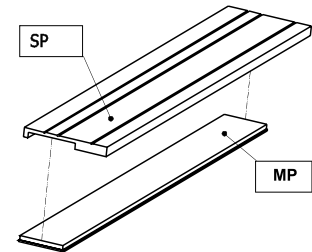
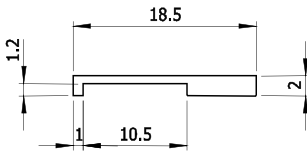

MAGNETIC BAND	MP100	MP200/MP200Z	MP500/MP500Z
Pole pitch	1+1 mm	2+2 mm	5+5 mm
Reference mark position	-	on request from left or right at pitches of 4 mm or multiples	on request from left or right at pitches of 10 mm or multiples
	<i>Note: With MP100 magnetic band, it is not possible to use any protective cover (CV or SP)</i>	<i>Note: Magnetic bang MP200Z is used only with reading head MTMxxxZ</i>	<i>Note: Magnetic bang MP500Z is used only with reading head MTXxxxZ</i>

## COLOR OF CABLE WIRES AND OUTPUT SIGNALS

MT-F		MT-AV	
Green	U1	A	A and B amplitude 0,6 V...1,2 V (~ 1V)
White	U2	B	R amplitude 0,25...0,6V (useful part)
Red	(5...28)V	(5...28)V	A and B phase shift 90° ±10° el.
Blue	0V	0V	Reference voltage U0 2,5 V
Brown	U0	R	Amplitudes of signals are referred to measurement made with 120 Ω impedance and power supply voltage of reading head 5V±5%.
Orange	U1	Ā	
Light-blue	U2	B	
Yellow	U0	R	
Shield	Shield	Shield	

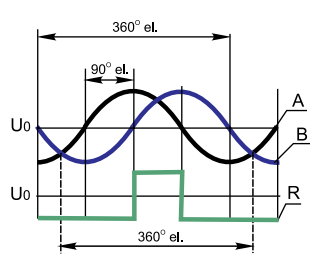
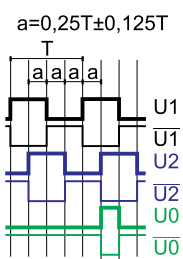

## ACCESSORIES

CONNECTORS FOR CABLE	B12 12-pin round connector	C12 12-pin round connector	D9 9-pin flat connector	D15 15-pin flat connector	RS10 10-pin round connector	ONC 10-pin round connector
DIGITAL READOUT DEVICES	CS3000			CS5000		

## ORDER FORM

READING HEAD VERSION:	OUTPUT SIGNALS AND RESOLUTION:	REFERENCE MARKS:	MAGNETIC BAND:	PROTECTIVE STEEL COVER CV:	OR ALUMINIUM PROTECTIVE SUPPORT SP:	EXTERNAL REFERENCE MARK ACTUATOR SME:	CABLE LENGTH:	CONNECTOR TYPE:
P - MTP M - MTM H - MTH	AV - Sine wave F05 - 0,5µm F10 - 1,0µm F50 - 5,0µm F100 - 10,0µm F250 - 25,0µm F500 - 50,0µm F1000 - 100,0µm F5000 - 500,0µm F10000 - 1000,0µm	C - standard, without reference mark; E - with external reference mark actuator; Z/L - made on magnetic band by order at any place. L - distance in mm from begin of ML	MP100/01 - 1m ... MP200/01 - 1m ... MP200Z/01 - 1m ... MP500/01 - 1m ... (20 m max for MP500)	W - without CV CV/01 - 1m CV/02 - 2m CV/03 - 3m ...	W - without SP SP/01 - 1m SP/02 - 2m SP/03 - 3m ...	0 - without SME 1 - with SME	01 - 1m 02 - 2m 03 - 3m ...	W - without connector B12 - round, 12 pins C12 - round, 12 pins D9 - flat, 9 pins D15 - flat, 15 pins RS10 - round, 10 pins ONC - round, 10 pins
ORDER EXAMPLE:	1) MTM-F100-C-MP200/03- SP/03-0-02/W							