

# Turmdrehkran

Tower Crane / Grue à tour / Gru a torre / Grúa torre /  
Guindaste de torre / Башенный поворотный кран

## 340 EC-B 16

340 EC-B 12

▶ 340 EC-B 16

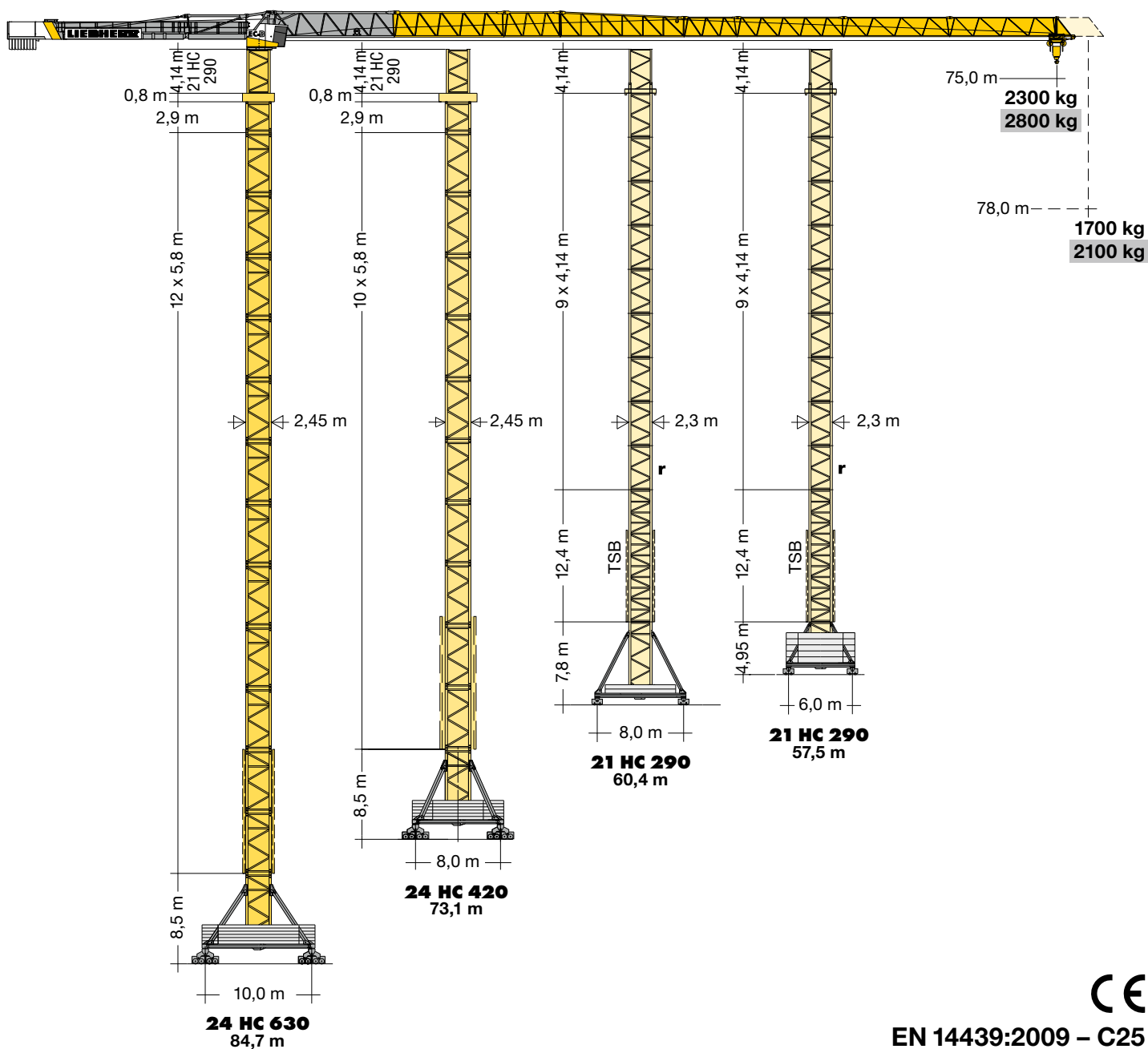

# LIEBHERR

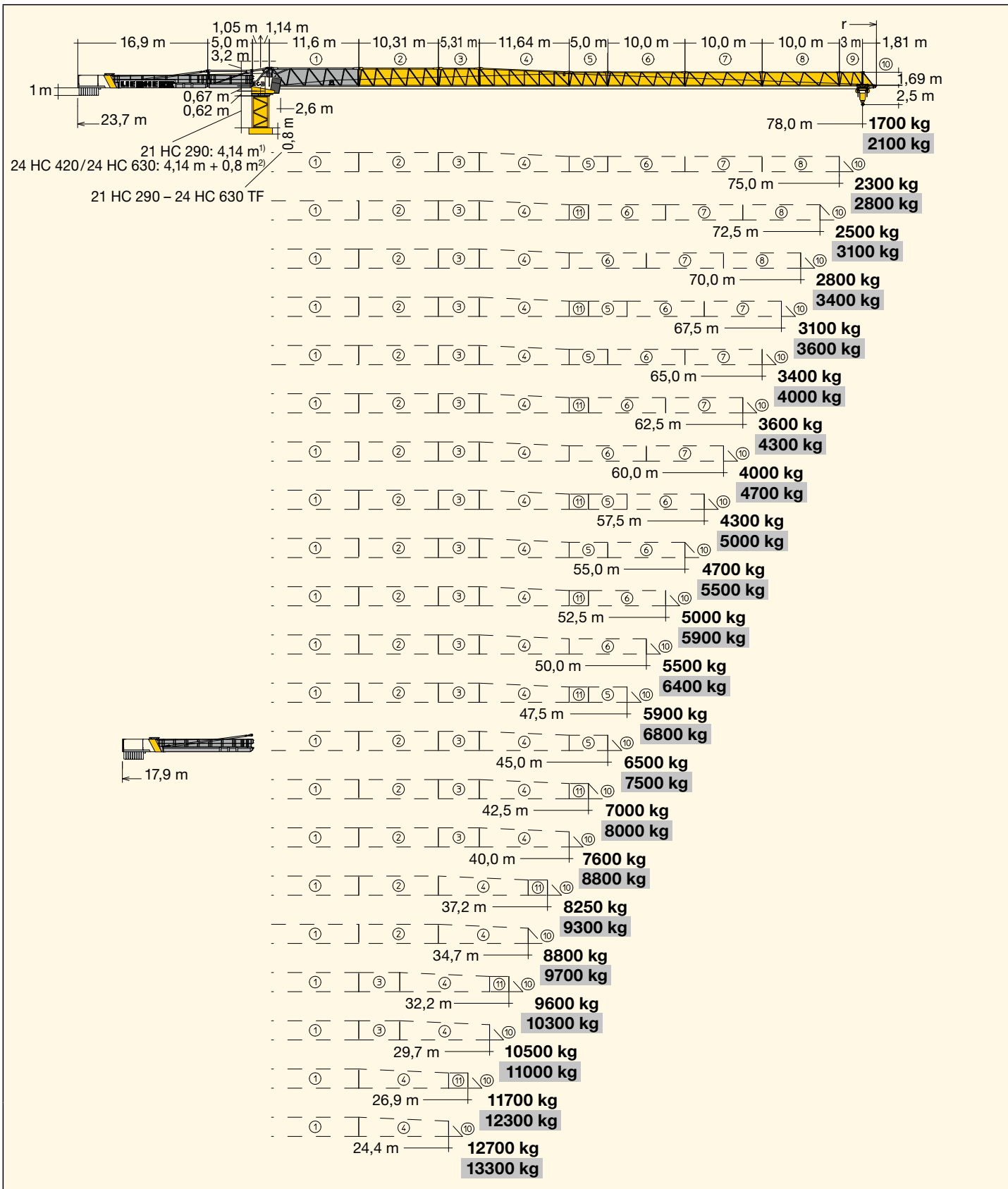

1) **Turmstück oder Kletterturmstück**/Tower section or climbing tower section/Élément de mât ou élément de mât télescopable/Elemento torre oppure elemento torre telescopabile/Tramo torre o tramo torre trepable/Segmento de torre ou segmento de torre para ascensão/Башенная секция или секция наращивания

2) **Turmstück 21 HC 290 + Übergangsrahmen 21 HC 290 – 24 HC 630 TF-0080c**/Tower section 21 HC 290 + transition frame 21 HC 290 – 24 HC 630 TF-0080c/Élément de mât 21 HC 290 + cadre de raccordement 21 HC 290 – 24 HC 630 TF-0080c/Elemento di torre 21 HC 290 + Adattatore torre 21 HC 290 – 24 HC 630 TF-0080c/Tramo torre 21 HC 290 + Marco de transición 21 HC 290 – 24 HC 630 TF-0080c/Segmento de torre 21 HC 290 + Quadro de transição 21 HC 290 – 24 HC 630 TF-0080c/Башенная секция 21 HC 290 + Переходная рама 21 HC 290 – 24 HC 630 TF-0080c

# Ausladung und Tragfähigkeit

Radius and capacity/Portée et charge/Sbraccio e portata/  
Alcances y cargas/Alcance e capacidade de carga/Вылет и грузоподъемность

m r		m/kg	m/kg																							
			18,0	20,0	24,4	26,9	29,7	32,2	34,7	37,2	40,0	42,5	45,0	47,5	50,0	52,5	55,0	57,5	60,0	62,5	65,0	67,5	70,0	72,5	75,0	78,0
<b>78,0 (r=79,6)</b>	2,6 – 13,5 <b>16000</b>	11610	10310	8200	7310	6500	5890	5380	4930	4490	4160	3860	3590	3340	3130	2930	2750	2580	2430	2290	2160	2040	1920	1820	1700	
<b>75,0 (r=76,6)</b>	2,6 – 15,5 <b>16000</b>	13580	12080	9660	8640	7700	7010	6410	5890	5390	5000	4660	4350	4070	3810	3580	3370	3180	3010	2840	2690	2550	2420	2300		
<b>72,5 (r=74,1)</b>	2,6 – 16,0 <b>16000</b>	14040	12480	9960	8910	7940	7220	6600	6070	5550	5150	4790	4470	4190	3930	3690	3480	3280	3100	2930	2780	2630	2500			
<b>70,0 (r=71,6)</b>	2,6 – 16,5 <b>16000</b>	14550	12950	10370	9290	8290	7550	6910	6360	5830	5410	5040	4710	4410	4140	3900	3680	3470	3280	3110	2950	2800				
<b>67,5 (r=69,1)</b>	2,6 – 17,0 <b>16000</b>	15040	13400	10760	9640	8610	7850	7190	6630	6080	5650	5260	4920	4610	4340	4080	3850	3640	3450	3270	3100					
<b>65,0 (r=66,6)</b>	2,6 – 17,5 <b>16000</b>	15520	13840	11110	9960	8900	8120	7440	6860	6290	5850	5460	5100	4790	4500	4240	4000	3790	3590	3400						
<b>62,5 (r=64,1)</b>	2,6 – 17,5 <b>16000</b>	15520	13850	11130	9980	8920	8140	7460	6880	6310	5870	5470	5120	4800	4520	4260	4020	3800	3600							
<b>60,0 (r=61,6)</b>	2,6 – 18,0 <b>16000</b>	16000	14300	11530	10360	9280	8470	7780	7180	6590	6140	5730	5370	5040	4740	4470	4230	4000								
<b>57,5 (r=59,1)</b>	2,6 – 18,0 <b>16000</b>	16000	14330	11600	10430	9360	8550	7860	7260	6680	6220	5810	5450	5120	4820	4550	4300									
<b>55,0 (r=56,6)</b>	2,6 – 18,5 <b>16000</b>	16000	14750	11940	10740	9640	8810	8100	7490	6890	6420	6000	5620	5280	4980	4700										
<b>52,5 (r=54,1)</b>	2,6 – 18,5 <b>16000</b>	16000	14750	11960	10760	9660	8830	8120	7510	6910	6440	6020	5650	5310	5000											
<b>50,0 (r=51,6)</b>	2,6 – 19,0 <b>16000</b>	16000	15170	12320	11100	9970	9120	8390	7760	7150	6660	6230	5850	5500												
<b>47,5 (r=49,1)</b>	2,6 – 19,0 <b>16000</b>	16000	15180	12350	11140	10020	9170	8450	7820	7200	6720	6290	5900													
<b>45,0 (r=46,6)</b>	2,6 – 19,5 <b>16000</b>	16000	15590	12710	11470	10320	9460	8710	8070	7440	6940	6500														
<b>42,5 (r=44,1)</b>	2,6 – 19,5 <b>16000</b>	16000	15600	12740	11510	10370	9510	8770	8130	7500	7000															
<b>40,0 (r=41,6)</b>	2,6 – 20,0 <b>16000</b>	16000	16000	13020	11740	10560	9670	8910	8250	7600																
<b>37,2 (r=38,8)</b>	2,6 – 20,0 <b>16000</b>	16000	16000	13020	11740	10560	9680	8910	8250																	
<b>34,7 (r=36,3)</b>	2,6 – 20,0 <b>16000</b>	16000	16000	12950	11660	10460	9570	8800																		
<b>32,2 (r=33,8)</b>	2,6 – 20,0 <b>16000</b>	16000	16000	12970	11680	10490	9600																			
<b>29,7 (r=31,3)</b>	2,6 – 20,0 <b>16000</b>	16000	16000	12980	11690	10500																				
<b>26,9 (r=28,5)</b>	2,6 – 20,0 <b>16000</b>	16000	16000	12990	11700																					
<b>24,4 (r=26,0)</b>	2,6 – 20,0 <b>16000</b>	16000	16000	12700																						

LM 1

m r		m/kg	m/kg																							
			18,0	20,0	24,4	26,9	29,7	32,2	34,7	37,2	40,0	42,5	45,0	47,5	50,0	52,5	55,0	57,5	60,0	62,5	65,0	67,5	70,0	72,5	75,0	78,0
<b>78,0 (r=79,6)</b>	2,6 – 14,5 <b>16000</b>	12770	11410	9200	8250	7380	6720	6160	5670	5200	4830	4500	4200	3930	3690	3470	3270	3080	2910	2760	2610	2480	2350	2230	2100	
<b>75,0 (r=76,6)</b>	2,6 – 16,5 <b>16000</b>	14660	13170	10710	9650	8670	7930	7300	6740	6200	5780	5400	5060	4760	4480	4230	4000	3780	3590	3410	3240	3080	2940	2800		
<b>72,5 (r=74,1)</b>	2,6 – 17,0 <b>16000</b>	15120	13610	11090	10010	9010	8250	7600	7030	6470	6040	5650	5300	4980	4700	4440	4200	3980	3770	3590	3410	3250	3100			
<b>70,0 (r=71,6)</b>	2,6 – 17,5 <b>16000</b>	15560	14020	11450	10350	9320	8540	7870	7290	6720	6270	5870	5510	5180	4890	4620	4370	4150	3940	3750	3570	3400				
<b>67,5 (r=69,1)</b>	2,6 – 18,0 <b>16000</b>	16000	14380	11700	10550	9490	8690	8000	7400	6810	6350	5940	5580	5250	4940	4670	4420	4190	3980	3780	3600					
<b>65,0 (r=66,6)</b>	2,6 – 18,5 <b>16000</b>	16000	14810	12110	10950	9860	9050	8340	7730	7130	6650	6230	5860	5510	5200	4920	4660	4420	4200	4000						
<b>62,5 (r=64,1)</b>	2,6 – 18,5 <b>16000</b>	16000	14840	12190	11040	9960	9150	8450	7840	7240	6770	6340	5960	5620	5310	5020	4760	4520	4300							
<b>60,0 (r=61,6)</b>	2,6 – 19,0 <b>16000</b>	16000	15230	12540	11370	10270	9440	8730	8100	7490	7000	6570	6180	5830	5510	5220	4950	4700								
<b>57,5 (r=59,1)</b>	2,6 – 19,0 <b>16000</b>	16000	15240	12580	11410	10320	9500	8780	8160	7540	7060	6630	6240	5880	5560	5270	5000									
<b>55,0 (r=56,6)</b>	2,6 – 19,5 <b>16000</b>	16000	15630	12940	11770	10660	9830	9100	8460	7830	7340	6890	6490	6130	5800	5500										
<b>52,5 (r=54,1)</b>	2,6 – 19,5 <b>16000</b>	16000	15640	13000	11840	10750	9920	9190	8560	7930	7440	7000	6590	6230	5900											
<b>50,0 (r=51,6)</b>	2,6 – 20,0 <b>16000</b>	16000	16000	13310	12130	11020	10170	9430	8780	8140	7630	7180	6770	6400												
<b>47,5 (r=49,1)</b>	2,6 – 20,0 <b>16000</b>	16000	16000	13330	12150	11040	10190	9450	8810	8170	7660	7210	6800													
<b>45,0 (r=46,6)</b>	2,6 – 20,5 <b>16000</b>	16000	16000	13690	12500	11390	10530	9780	9130	8480	7960	7500														
<b>42,5 (r=44,1)</b>	2,6 – 20,5 <b>16000</b>	16000	16000	13700	12530	11420	10560	9820	9160	8510	8000															
<b>40,0 (r=41,6)</b>	2,6 – 21,0 <b>16000</b>	16000	16000	14040	12860	11740	10880	10120	9460	8800																
<b>37,2 (r=38,8)</b>	2,6 – 21,0 <b>16000</b>	16000	16000	13970	12760	11610	10740	9970	9300																	
<b>34,7 (r=36,3)</b>	2,6 – 21,0 <b>16000</b>	16000	16000	13840	12570	11380	10480	9700																		
<b>32,2 (r=33,8)</b>	2,6 – 21,0 <b>16000</b>	16000	16000	13750	12440	11220	10300																			
<b>29,7 (r=31,3)</b>	2,6 – 21,0 <b>16000</b>	16000	16000	13630	12260	11000																				
<b>26,9 (r=28,5)</b>	2,6 – 21,0 <b>16000</b>	16000	16000	13650	12300																					
<b>24,4 (r=26,0)</b>	2,6 – 21,0 <b>16000</b>	16000	16000	13300																						

Load-Plus

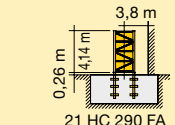
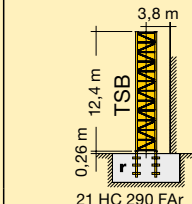
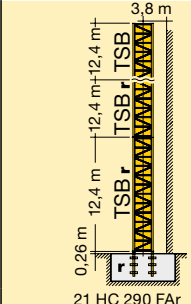
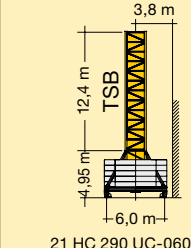
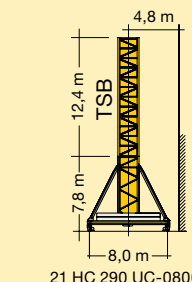
4,14 m		4,14 m + 2,07 m	<b>21 HC 290</b>				
							
10		-	57,0 <sup>*)4)</sup>	-	-	-	-
9	9 + 1	40,4 <sup>*)</sup>	54,9 <sup>*)4)</sup>	-	-	57,5 <sup>*)3)</sup>	60,4 <sup>*)3)</sup>
8	8 + 1	38,3 <sup>*)</sup>	50,8 <sup>*)</sup>	-	-	55,5 <sup>*)</sup>	58,3 <sup>*)</sup>
7	7 + 1	36,3	48,7 <sup>*)</sup>	-	-	53,4 <sup>*)</sup>	56,2 <sup>*)</sup>
6	6 + 1	34,2	46,6	69,4 <sup>*)</sup>	-	51,3	54,2
5	5 + 1	32,1	44,5	67,3 <sup>*)</sup>	-	49,2	52,1
4	4 + 1	30,1	42,5	65,3	-	47,2	50,0
3	3 + 1	28,0	40,4	63,2	-	45,1	48,0
2	2 + 1	25,9	38,3	61,1	-	43,0	45,9
1	1 + 1	23,8	36,3	59,0	-	41,0	43,8
0	0 + 1	21,8	34,2	57,0	-	38,9	41,7
		19,7	32,1	54,9	-	36,8	39,7
		17,6	30,1	52,8	-	34,8	37,6
		15,6	28,0	50,8	-	32,7	35,5
		13,5	25,9	48,7	-	30,6	33,4
		11,4	23,9	46,6	-	28,5	31,4
		9,4	21,8	44,5	-	26,5	29,3
		7,3	19,7	42,5	-	24,4	27,2
		5,2	17,6	40,4	-	22,3	25,2
		3,2	15,6		-	20,3	23,1
		m	m	m	m	m	m
							

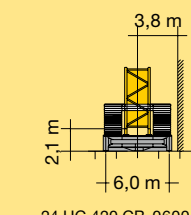
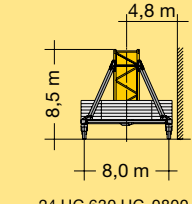
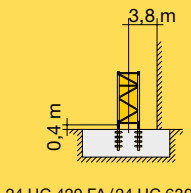
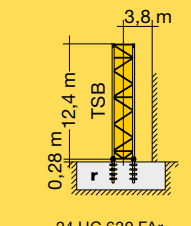
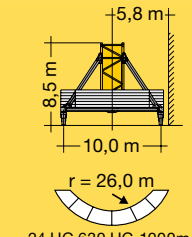
5,8 m		5,8 m + 2,9 m	<b>24 HC 420</b>		<b>24 HC 420 / 24 HC 630</b>	<b>24 HC 630</b>	
							
13	13 + 1	-	-	-	82,4 <sup>*)8)</sup>	-	-
12	12 + 1	-	-	-	79,5 <sup>*)7)</sup>	91,7 <sup>*)</sup>	-
11	11 + 1	-	-	-	76,6 <sup>*)7)</sup>	88,8 <sup>*)</sup>	84,7 <sup>*)</sup>
10	10 + 1	66,7 <sup>*)</sup>	73,1 <sup>*)</sup>	-	73,7 <sup>*)6)</sup>	85,9	81,8 <sup>*)</sup>
9	9 + 1	63,8 <sup>*)</sup>	70,2 <sup>*)</sup>	-	70,8 <sup>*)6)</sup>	83,0	78,9
8	8 + 1	60,9	67,3	-	67,9 <sup>*)5)</sup>	80,1	76,0
7	7 + 1	58,0	64,4	-	65,0 <sup>*)</sup>	77,2	73,1
6	6 + 1	55,1	61,5	-	62,1 <sup>*)</sup>	74,3	70,2
5	5 + 1	52,2	58,6	-	59,2	71,4	67,3
4	4 + 1	49,3	55,7	-	56,3	68,5	64,4
3	3 + 1	46,4	52,8	-	53,4	65,6	61,5
2	2 + 1	43,5	49,9	-	50,5	62,7	58,6
1	1 + 1	40,6	47,0	-	47,6	59,8	55,7
0	0 + 1	37,7	44,1	-	44,7	56,9	52,8
		34,8	41,2	-	41,8	54,0	49,9
		31,9	38,3	-	38,9	51,1	47,0
		29,0	35,4	-	36,0	48,2	44,1
		26,1	32,5	-	33,1	45,3	41,2
		23,2	29,6	-	30,2	42,4	38,3
		20,3	26,7	-	27,3	39,5	35,4
		17,4	23,8	-	24,4	36,6	32,5
		14,5	20,9	-	21,5	33,7	29,6
		11,6	18,0	-	18,6	30,8	26,7
		8,7	15,1	-	15,7	27,9	23,8
		5,8	12,2	-	12,8	25,0	20,9
		m	m	m	m	m	m
							

**Turmstücke 24 HC 630 müssen am Turmfuß eingebaut werden. Details siehe Bedienungsanleitung.** / Tower sections 24 HC 630 must be installed on the tower base. See operating manual for further details. / Les éléments de mât 24 HC 630 doivent être montés en pied de grue. Voir les détails dans les instructions d'emploi. / Elementi torre 24 HC 630 devono essere montati alla base torre. Si veda il manuale istruzioni per i dettagli. / Los tramos torre de la 24 HC 630 tienen que ser montados en el pie de torre. Más detalles en las instrucciones de montaje. / Segmentos de torre 24 HC 630 devem ser instalados sobre o segmento base. Para mais detalhes consultar manual de instrução. / Башенные секции 24 HC 630 должны монтироваться в основании башни. Подробную информацию смотрите в инструкции по эксплуатации.

- \*) 1 x 21 HC 290 TS-0414cr
- 2 x 21 HC 290 TS-0414cr
- 1 x 24 HC 630 TS-0580c
- 2 x 24 HC 630 TS-0580c
- 3 x 24 HC 630 TS-0580c
- 4 x 24 HC 630 TS-0580c

**Weitere Hubhöhen, Auslegerlängen sowie Klettern im Gebäude auf Anfrage.** / Further hoist heights and jib lengths as well as climbing inside the building on request. / Autres hauteurs sous crochet et longueurs de flèche ainsi que hissage dans le bâtiment sur demande. / Ulteriori altezze gancho, lunghezze braccio così come telescopaggio all'interno dell'edificio: su richiesta. / Para alturas bajo gancho superiores, otros alcances y trepado en el interior del edificio, consultar. / Outras alturas de elevação, comprimentos de lança e subida no edifício: sob consulta. / Другие высоты подъема, длины стрелы и самоподъем в здании – по запросу.

**r = verstärkt / reinforced / renforcé / rinforzato / reforzado / reforçado / усиленный**

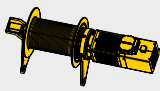
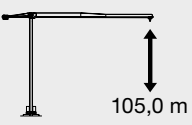
	↔ <b>stufenlos / stepless / régl. continu / regl. progressiva / sin escalones / sem degraus / бесступенчатый</b>
65 kW FU WIW 280 MZ 423	kg m/min
<b>3 Lagen</b> Layers Couches Avvolgimenti Camadas Capas Слоёв	<b>1</b> 16000 0 ↔ 21 3200 0 ↔ 88
 105,0 m	
max. 276,0 m <sup>9)</sup>	

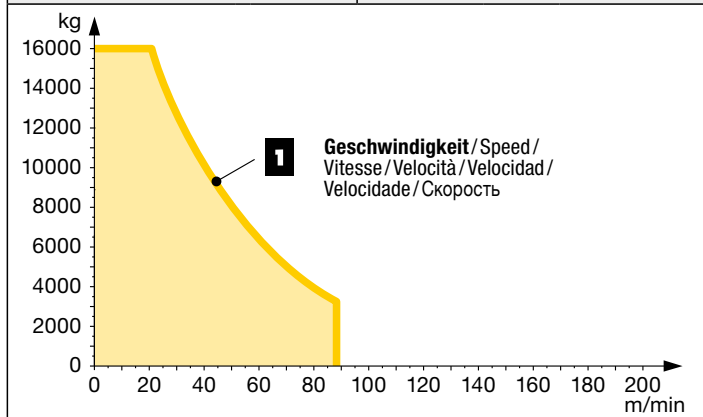

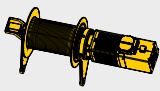
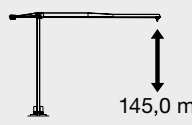
	↔ <b>stufenlos / stepless / régl. continu / regl. progressiva / sin escalones / sem degraus / бесступенчатый</b>
65 kW FU <b>[SD.shift]</b> WIW 280 WZ 401	kg m/min
<b>4 Lagen</b> Layers Couches Avvolgimenti Camadas Capas Слоёв	<b>1</b> 16000 0 ↔ 21 3500 0 ↔ 81 <b>2</b> 7800 0 ↔ 41 1400 0 ↔ 150
 145,0 m	
max. 276,0 m <sup>9)</sup>	

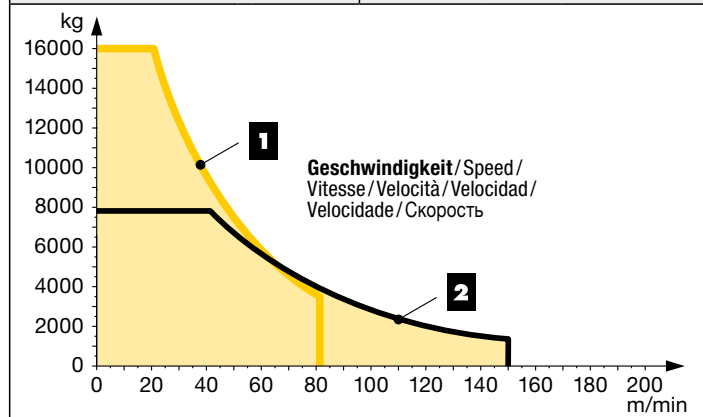

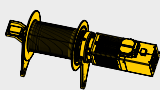
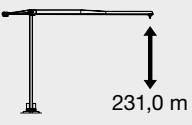

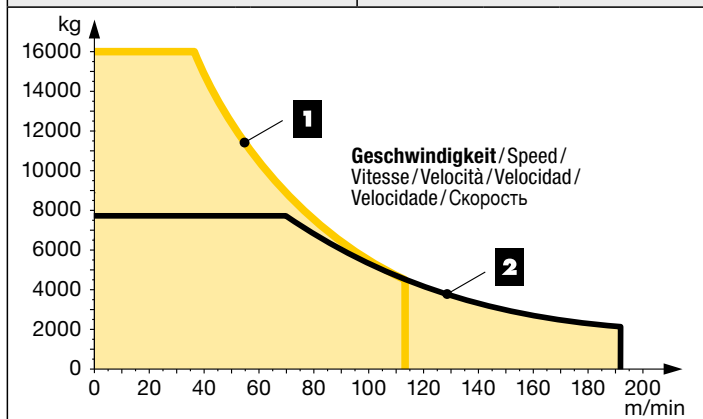

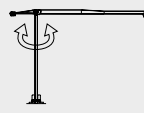
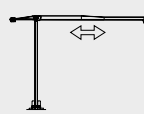
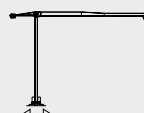
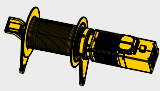
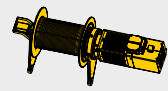























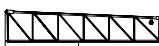

	↔ <b>stufenlos / stepless / régl. continu / regl. progressiva / sin escalones / sem degraus / бесступенчатый</b>
110 kW FU <b>[SD.shift]</b> WIW 300 WZ 402	kg m/min
<b>6 Lagen</b> Layers Couches Avvolgimenti Camadas Capas Слоёв	<b>1</b> 16000 0 ↔ 36 4500 0 ↔ 113 <b>2</b> 7700 0 ↔ 70 2100 0 ↔ 192
 231,0 m	
max. 276,0 m <sup>9)</sup>	





























	0 ↔ U/min 0,7 sl./min tr./min	2 x 7,5 kW FU
	0 ↔ 88,0 m/min	11 kW FU
	25,0 m/min	4 x 7,5 kW (24 HC 420 / 24 HC 630) 2 x 7,5 kW (21 HC 290)
	<b>kVA</b>	 65 kW FU   110 kW FU 89,0   125,0



<sup>9)</sup> Weitere Hublastdaten: siehe Betriebsanleitung. / Further hoist load data: see instruction manual. / Autres données de la charge de levage: voir manuel d'instruction. / Altri dati sui carichi sollevati: consultare il manuale d'istruzione. / Alturas bajo granchos superiores según manual. / Outras tabelas de carga: consultar manual de instruções. / Другие данные по весу поднимаемых грузов: см. инструкцию по эксплуатации.

kVA reduzierbar bei zu geringer Netz-Anschlussleistung, siehe BAL. / kVA can be reduced in case of too little power of the mains, see instruction manual. / kVA peut être réduit en cas de trop faible puissance du réseau, voir manuel d'instruction. / kVA riducibili in caso di potenza di rete ridotta (si veda manuale uso e manutenzione) / kVA variable para potencia de red demasiado pequeña, ver Manual de instrucciones. / kVA reduzível no caso de capacidade da rede elétrica muito baixa, ver manual de instruções. / Количество кВА может быть сокращено до минимальной общей потребляемой мощности, см. инструкцию по эксплуатации.

<b>Kranoberteil</b>		Upper part of crane / Partie supérieure de grue / Parte superiore della gru / Parte superior grúa / Parte superior do guindaste / Верхняя часть крана	L (m)	B (m)	H (m)	kg <sup>(10)</sup>		
Pos. Item Rep Voce Pos. Ref. Поз.	Anz. Qty. Qte. Qta. Cant. Cant. Кол-во	<b>Drehbühne kpl. mit Kugeldrehkranz und KUD-Auflage 21 HC 290 mit Klappspitze, Kabine und Schaltschrank mit Podesten</b> / Slewing platform complete with slewing ring and slewing ring support 21 HC 290 with folding head, cabin and switch cabinet with platforms / Plate-forme tournante complète avec couronne d'orientation et pivot d'orientation 21 HC 290 avec pointe pliante, cabine et armoire électrique avec plates-formes / Piattaforma girevole con ralla e supporto ralla 21 HC 290 con punta ribaltabile, cabina e quadro elettrico con pedane / Plataforma giratoria completa con corona de rotación y asiento de pista 21 HC 290 con punta abatible y armario eléctrico con plataforma / Plataforma de giro completa com coroa de giro e assento da coroa 21HC 290, com cavalete dobrável, cabine e painel elétrico com plataformas / Поворотная платформа в сб. с шариковым поворот- ным кругом и рамой ОПУ 21 HC 290 с откидным кронштейном, кабиной и распределительным электрошкафом с площадками			6,57	2,42	2,55	11800
1	1							
1a	1	<b>Drehbühne mit Kugeldrehkranz und KUD-Auflage 21 HC 290</b> / Slewing platform with slewing ring and slewing ring support 21 HC 290 / Plate-forme tournante avec couronne d'orientation et pivot d'orientation 21 HC 290 / Piattaforma girevole con ralla e supporto ralla 21 HC 290 / Plataforma giratoria con corona de rotación y asiento de pista 21 HC 290 / Plataforma de giro com coroa de giro e assento da coroa 21 HC 290 / Поворотная платформа с шариковым поворотным кругом и рамой ОПУ 21 HC 290			3,67	2,39	2,45	7050
1b	1	<b>Schaltschrank mit Podest</b> / Switch cabinet with platform / Armoire électrique avec plate-forme / Quadro elettrico con pedana / Armario eléctrico con plataforma / Armário elétrico com plataforma / Электрошкаф с площадкой			2,31	2,19	1,95	1550
1c	1	<b>Kabine mit Podest</b> / Cabin with platform / Cabine avec plate-forme / Cabina con pedana / Cabina con plataforma / Cabina com plataforma / Кабина с площадкой			2,40	2,09	2,47	1700
1d	1	<b>Klappspitze</b> / Folding head / Pointe pliante / Punta ribaltabile / Pluma / Cavalete dobrável / Откидной кронштейн			1,86	1,45	2,34	1500
2	1	<b>Gegenausleger lang</b> / Counter-jib, long / Contre-flèche longue / Controffrecia lunga / Contrapluma larga / Contra-lança, longa / Консоль противовеса, длинная			11,89	2,33	3,01	16600
2a	1	<b>Gegenausleger kurz</b> / Counter-jib, short / Contre-flèche courte / Controffrecia corta / Contrapluma corta / Contra-lança, curta / Консоль противовеса, короткая			11,89	2,33	2,67	13100
2b	1	<b>Gegenausleger-Zwischenstück</b> / Intermediate counter-jib section / Elément interm. de contre-flèche / Spezzone di controbraccio / Tramo intermedio de contrapluma / Peça suplementar da contra- lança / Промежуточная секция консоли противовеса			6,26	1,85	2,45	3500
3	1	<b>Ausleger-Anlenkstück</b> / Jib heel section / Pied de flèche / Sezione articolata braccio / Pluma tramo primero / Base articulada de lança / Корневая секция стрелы			11,92	1,43	2,53	① 5500
4	1	<b>Ausleger-Zwischenstück</b> / Intermediate jib section / Elément intermédiaire de flèche / Sezione intermedia braccio / Tramo intermedio pluma / Peça suplementar da lança / Промежуточная секция стрелы			10,65 5,64	1,28 1,28	2,48 2,47	② 2700 ③ 1150
5	1	<b>Ausleger-Zwischenstück</b> / Intermediate jib section / Elément intermédiaire de flèche / Sezione intermedia braccio / Tramo intermedio pluma / Peça suplementar da lança / Промежуточная секция стрелы			11,94	1,28	2,45	④ 2050
6	1	<b>Ausleger-Zwischenstück</b> / Intermediate jib section Elément intermédiaire de flèche / Sezione intermedia braccio / Tramo intermedio pluma / Peça suplementar da lança / Промежуточная секция стрелы			5,28 10,25 10,23 10,22 3,22 2,78	1,28 1,28 1,28 1,28 1,28 1,28	1,95 1,95 1,94 1,93 1,93 1,95	⑤ 760 ⑥ 1280 ⑦ 850 ⑧ 660 ⑨ 240 ⑩ 460
7	1	<b>Ausleger-Kopfstück</b> / Jib head section / Pointe de flèche / Punta braccio / Tramo punta de pluma / Cabeça de lança / Концевая секция стрелы			1,91	1,28	2,12	⑪ 260
8	1	<b>Laufkatze und Lsthaken</b> / Trolley and hook / Chariot de distribution et crochet / Carrello con gancio / Carrito y gancho / Carro de ponte e gancho / Грузовая тележка и грузовой крюк			2,13	1,62	1,71	960
9	1	<b>Fahrkorb</b> / Maintenance cage / Nacelle d'entretien / Cestello di manutenzione / Plataforma de mantenimiento / Передвижная платформа			0,66	0,57	1,17	25

Pos. Item Rep. Voce Pos. Ref. Поз.	Anz. Qty. Qte. Qta. Cant. Cant. Кол-во				L (m)	B (m)	H (m)	kg <sup>(10)</sup>	
<b>Turm</b>		<b>Tower / Mât / Torre Torre / Torre / Башня</b>							
10	1	<b>Turmstück / Tower section / Élément de mât / Elemento di torre / Tramo torre / Torre / Башенная секция</b>	 	 	21 HC 290 TS-0414c 4,14 21 HC 290 TS-0414cr 4,14 21 HC 290 TS-1242c 12,42 24 HC 420 TS-0290c 3,19 24 HC 420 TS-0580c 6,09 24 HC 420 TS-1160 11,90 24 HC 630 TS-0290c 3,38 24 HC 630 TS-0580c 6,28 24 HC 630 TS-1160 12,10	4,14 2,30 2,30 2,30 2,45 2,45 2,45 2,45 2,45 2,45	2,30 2,30 2,30 2,45 2,45 2,45 2,45 2,45 2,45	2500 2950 6100 2950 4500 7200 4050 6450 10750	
11	1	<b>Grundturmstück / Base tower section / Mât de base / Elemento di torre base / Tramo base / Peça de base de torre / Секция основания</b>			21 HC 290 TSB-1242c 12,42 24 HC 630 TSB-1242c 12,42 24 HC 630 TSB-1242r 12,42	12,42 2,68 2,68	2,30 2,68 2,68	8200 14500 17300	
12	1	<b>Kletterturmstück / Climbing tower section / Élément de hissage de mât / Elemento torre di telescopaggio / Tramo de trepado / Tramo de telescopagem / Секция самоподъема</b>			21 HC 290 ECTS	4,14	2,30	2,45	3300
13	1	<b>Übergangsrahmen / Transition frame / Cadre de raccordement / Adattatore torre / Chasis de unión / Quadro adaptador / Переходная рама</b>			21 HC 290 – 24 HC 630 TF-0080c	3,16	2,85	1,08	3700
<b>Klettereinrichtung</b>		<b>Climbing equipment / Equipement de télescopage / Attrezzatura per allungamento della gru / Equipo de trepado / Acessórios p. subida no edifício / Обойма наращивания</b>							
14	1	<b>Führungsstück kpl., geteilt / Guide section cpl., split / Cage télescopique cpl., devisée / Gabbia de sopraelevazione compl., suddivisa / Torre de montaje completa, dividida / Peça de guia compl., subdividida / Направляющая секция в сб., разъемная</b>			21 HC 290 ECGS 24 HC 630 ECGS	8,39 12,39	2,75 2,78	2,70 (3,04) 1,58	5800 8550
15	1	<b>Hydraulikanlage, Stütz- und Klettertraverse / Hydraulic unit, supporting and climbing crossmembers / Système hydraul. avec traverses d'appui et de télescop. / Sist. idraul., traversa di appoggio e allugam. gru / Sistema hidráulico con traviesa de apoyo y trepado / Instalação hidráulica, travessa de apoio e subida / Гидроагрегат, стойка-упор и траверса обоймы наращивания</b>			21 HC 290 24 HC 630	2,10 2,60	1,25 1,50	1,00 1,00	1150 1900
<b>Unterwagen</b>		<b>Undercarriage / Châssis / Carro / Carro con mástil / Carro de guindaste / Опорная рама</b>							
16	4	<b>Ausgleichsschwinge mit Schwingenlager / Pivot for wheel box / Chape pour bogie / Bilanciere di equilibratura con cuscinetto bilanciere / Balancin / Balancim com suporte / Балансир с шарнирной опорой</b>			24 HC 630	1,60	0,72	1,48	1470
17	2	<b>Fahrschemel mit Antrieb / Rail bogie with drive / Bogie moteur / Telaio con gruppo propulsore / Caja rodillo motoriz / Quadra sem grupa de propulsão / Подрамник с приводом</b>			21 HC 290 24 HC 630	1,63 (1,46) 1,45	0,92 (0,84) 0,82	0,95 (0,87) 0,72	1690 (920) 1200
18	2	<b>Fahrschemel ohne Antrieb / Rail bogie without drive / Bogie fou / Telaio senza gruppo propulsore / Caja rodillo conducido / Quadra com grupa de propulsão / Подрамник без привода</b>			21 HC 290 24 HC 630	1,37 (1,15) 1,30	0,62 (0,60) 0,40	0,95 (0,87) 0,72	1340 (880) 950
19	2	<b>Tragholm lang / Long support arm / Longeron long / Longherone lungo / Brazo soporte largo / Travessa comprida / Несущая балка, длинная</b>			21 HC 290 24 HC 630	9,10 (11,95) 7,32 (5,91)	0,80 (0,82) 0,92 (0,92)	0,80 (0,80) 0,93 (0,93)	1650 (2200) 2330 (1980)
20	2	<b>Tragholm kurz / Short support arm / Longeron court / Longherone corto / Brazo soporte corto / Travessa curta / Несущая балка, короткая</b>			21 HC 290 24 HC 630	4,45 (5,58) 7,14 (5,73)	0,77 (0,65) 0,92 (0,80)	0,77 (0,77) 0,90 (0,90)	800 (1040) 2180 (1780)
21	2+2	<b>Randträger / Border support / Traverse / Supporti base Traviesas / Apoio de bordo / Стяжная балка</b>			21 HC 290 24 HC 630	5,46 – 5,40 (7,52 – 7,46) 9,30 (7,30)	0,11 – 0,18 (0,10 – 0,17) 0,24 (0,14)	0,16 – 0,38 (0,10 – 0,38) 0,41 (0,14)	175 – 525 (370 – 915) 870 (400)
22	4	<b>Stützholm / Support strut / Hauban de châssis / Correnti di appoggio / Tirante vertical / Travessa de apoio / Опорный подкос</b>			21 HC 290 24 HC 630	4,14 (6,55) 6,98 (6,05)	0,18 (0,22) 0,26 (0,26)	0,25 (0,25) 0,39 (0,39)	320 (600) 1190 (1140)
23	1	<b>Unterwagen-Turmstück / Undercarriage tower section / Mât de châssis / Elemento di torre del carro / Tramo de carro / Peça de torre do chassis / Опорная башенная секция</b>			21 HC 290 24 HC 630	3,73 (6,70) 6,61	2,62 (2,53) 2,44	2,62 (2,53) 2,44	2920 (4030) 7930
24		<b>Kleinteile, Seile und Abspannungen / Small parts, ropes and holding bars / Accessoires, câbles et tirants / Accessori, funi e attrezzi di ancoraggio / Despieces, cables y tirantes / Acessórios, cabos e peças de ancoragem / Мелкие детали, Канаты и Пристежки</b>			21 HC 290 24 HC 630	9,00	1,60	1,00	4000

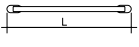
Pos. Anz.  
Item Qty.  
Rep. Qte.  
Voce Qta.  
Pos. Cant.  
Ref. Cant.  
Поз. Кол-во

				L (m)	B (m)	H (m)	kg <sup>10)</sup>	
<b>Fundamentkreuz</b>		<b>Cruciform base/Châssis en croix/Crociera/ Carro de guindaste/Base cruciforme/Фундаментная крестовина</b>						
25	2	<b>Hauptträger</b> / Main beam / Poutre principale / Traversa portante / Viga principal / Travessa comprida / основная балка		24 HC 420 CB-0600	9,20	1,10	1,53	8300
26	2	<b>Randträger</b> / Border support / Traverse / Supporti base / Traviesa / Apoio de bordo / Стяжная балка		24 HC 420 CB-0600	5,50	0,25	0,66	560
27	4	<b>Adapter HC-Turm</b> / Adapter for HC tower / Adaptateur pour mât HC / Adattatore torre HC / Tramo transición HC / Adaptador para torre HC / Переходной элемент башни HC		24 HC 420 CB-0600	0,43	0,43	0,64	320

( ) **Angaben in Klammern gelten für 8 m-Unterwagen.** / The data in brackets are valid for an undercarriage of 8 m. / Les données techniques indiquées entre parenthèses sont valables pour un châssis de 8 m. / Caratteristiche in (..) valgono per carro di 8 m. / Los datos entre paréntesis son válidos para carro de 8 m. / Características em (..) válidas pelo chassis de 8 m. / Данные в скобках относятся к 8-метровой опорной раме.

<sup>10)</sup> **Einzelgewichte** / Single weights / Poids individuels / Singoli pesi / Tramo punta de pluma / Pesos de peças componentes / Индивидуальный вес

**Änderungen vorbehalten!** / Subject to technical modifications! /  
Sous réserves de modifications! / Con riserva di modifiche! /  
¡Sujeto a modificaciones sin previo aviso! / Sujeto a modificaciones! /  
С правом внесения изменений!

**Sämtliche Angaben erfolgen ohne Gewähr.** / This information is supplied without liability. /  
Ces renseignements sont sans garantie. / Tutte le indicazioni fornite senza garanzia. /  
Declinamos toda responsabilidad derivada de la información proporcionada. / Declinamos  
qualquer responsabilidade quanto à informação fornecida. / Все данные указаны без обязательств.

TCS-002375-LBC-01 • EN 14439:2009 – A3 • BGL C.0.10.0315 • 04.19

Printed in Germany.

Liebherr-Werk Biberach GmbH  
Postfach 1663, D-88396 Biberach an der Riss  
☎ +49 73 51 41-0, Fax: +49 73 51 41 22 25  
www.liebherr.com, E-Mail: info.lbc@liebherr.com

Liebherr Industrias Metálicas, S.A.  
Polígono Industrial Agustinos, calle E, E-31014 Pamplona  
☎ +34 94829 70-00, Fax +34 94829 70-29  
www.liebherr.com, E-Mail: info.lim@liebherr.com