



Sync | Size and Shape Particle Analyser

Synchronising Size & Shape

Wet & Dry Measurements

0.01 to 4000 μm



CEMENT



GLASS BEADS



PAINTS / PIGMENTS



CERAMICS



BATTERIES



3D PRINTING



INDUSTRIAL MINERALS



METAL POWDERS



OIL & GAS



CHEMICALS



PHARMACEUTICALS



COATINGS

Laser Diffraction

Particle size measurement by laser diffraction (LD) technology has become the most used technique research and industry wide, among both suppliers and users of particulate systems. It's become a de facto standard for outgoing and incoming size quality control, reporting the equivalent spherical diameter (ESD) in volume % over a typical range of 10 nanometres to 2-3 millimetres.

In a laser diffraction measurement, a laser beam is passed through a well-dispersed particle sample and particle size is measured by detecting the intensity of the

scattered light produced. In Microtrac's technology, this scattered light is measured at various angles up to 163 degrees. Small particles scatter light at large angles while large particles scatter light at small angles relative to the laser beam. The data is collected continuously throughout the measurement, is analysed and put through an algorithm using Microtrac's innovative modified Mie scattering theory and produces accurate particle size distributions for both spherical and non-spherical particles.

A global leader in laser diffraction instrumentation for over 40 years

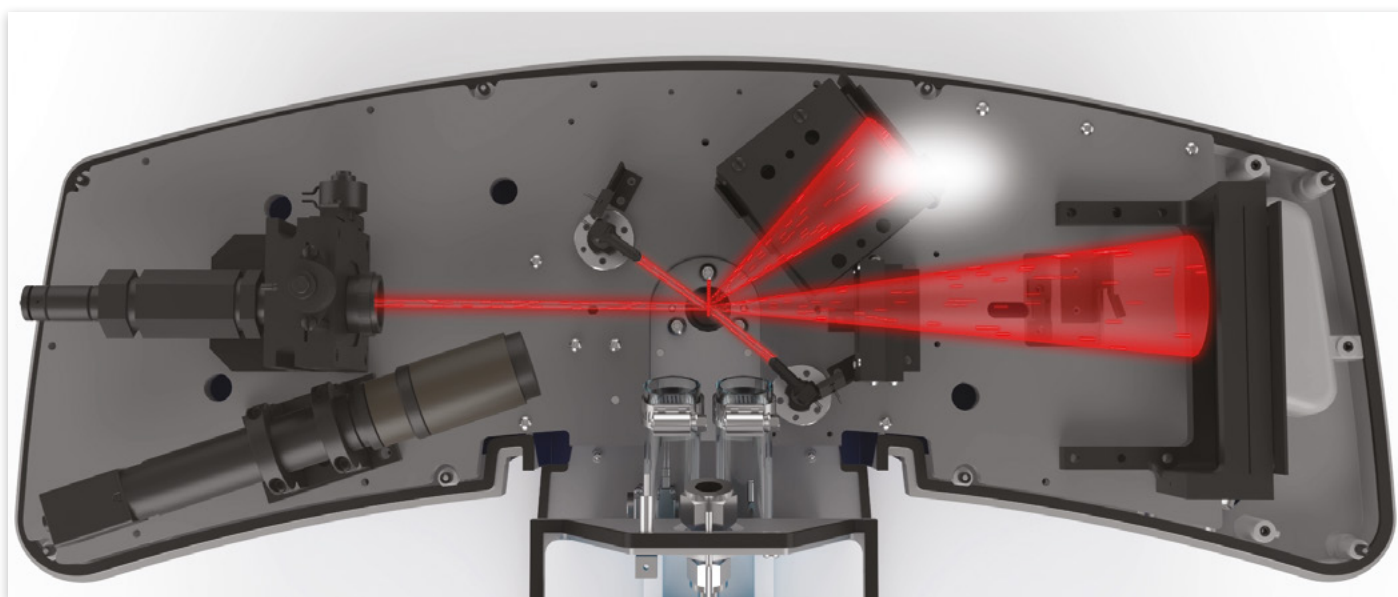

Patented tri-laser design utilising all red lasers, all blue lasers or a combination. These different configurations give better accuracy depending on the size of your particles.

Fixed optics with solid state laser diodes provide long-lasting ruggedness, reliability, and requires zero stabilisation time.

Fourier optical system delivers the optimal pattern of light by assuring that the angle of incidence is constant.

Always-on volume direct detectors are collecting light throughout the entire measurement, providing the most amount of data for analysis and reporting.

The characterisation of particulate systems, once dominated strictly by size analysis, is evolving. Particle morphology, as measured by dynamic image analysis (DIA), provides detailed information regarding the physical properties of materials. The key properties of particulate systems and the products manufactured from them can change with no significant difference in the LD size distribution reported. Image analysis can rapidly identify problems and significantly reduce troubleshooting time.

Particles in a flowing stream, backlit by a high speed strobe light, are photographed by a high resolution digital camera to create a video file of images for the flowing particles. The pixel size of the camera and the number of pixels in the image are used to measure a large number of particle size and shape parameters, along with a measure of transparency.

Microtrac's DIA measurement principle involves a sample that is introduced through a nozzle for dry dispersion and analysis or suspended in a circulating fluid for wet analysis. As particles enter the sensing zone, the high speed camera will take photos and transfer the information to a PC. Microtrac's sophisticated software delivers over 30 size and shape parameters to the user.

Some of the parameters of importance to customers include length, width, aspect ratios (W/L), sphericity, transparency, solidity, and surface roughness, among many others.

Although the measurement technology of DIA is straightforward, the data analysis used to identify and solve problems is extremely powerful.

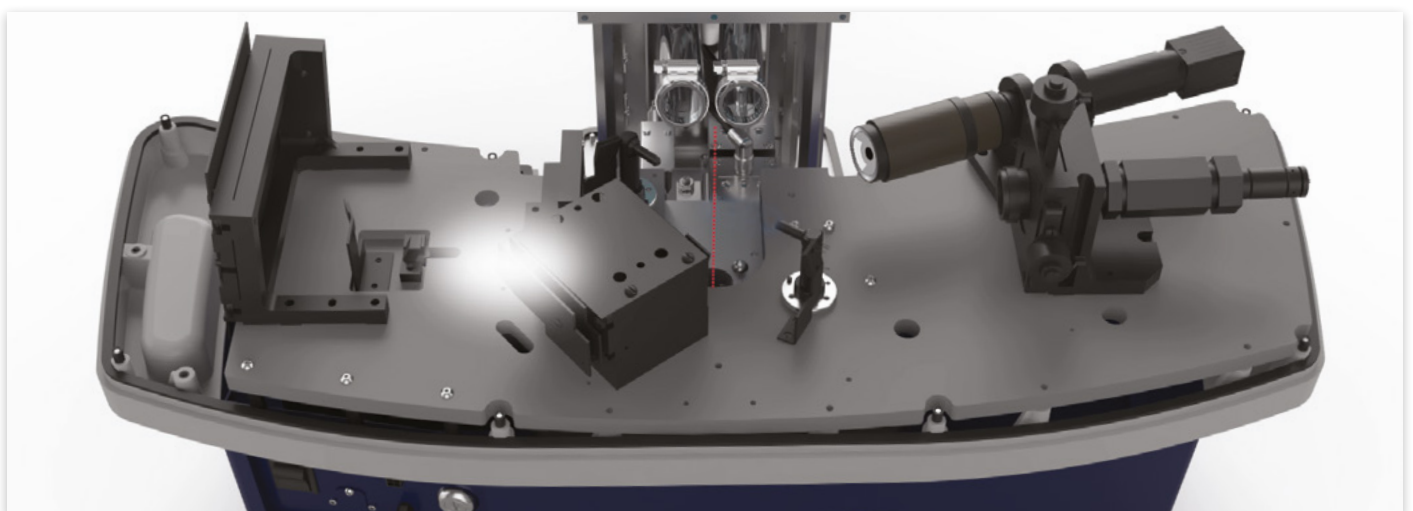
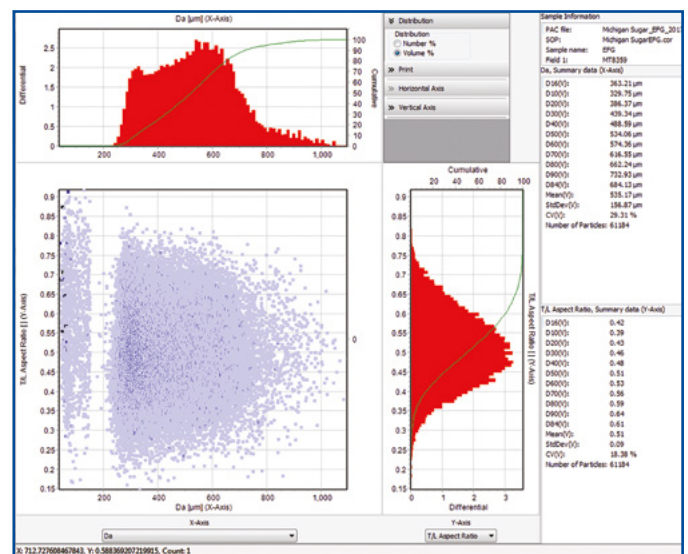

Introducing the Sync

Microtrac's synchronous size and shape analyser, Sync, integrates the world's leading laser diffraction technology with the world's leading dynamic image analysis technology – *same bench, same sample, same run, same flow cell, same user interface*. Users can now get their tried and true particle size distribution together with particle morphology in a single, easy to use graphical user interface.



Whether your sample is wet or dry, big or small

Using our patented methodology, the Sync interrogates particles, wet or dry, with laser light while a high-speed digital camera takes images simultaneously. The data collected is processed by our FLEX software and presents the user with particle size and shape information. While the software is powerful, the graphical user interface is intuitive and easy to use. The Sync enables users to get more detailed information about their material than ever before and will quickly render size-only instrumentation outdated and incomplete.



small, regular or irregular — think Sync.

FlowSync: Wet Delivery System

The FlowSync's automated filling, de-aerating, pre-circulating and circulating operation means each sample is handled with a consistency that improves the repeatability of particle size distribution and shape data.

Consistency

An in-line ultrasonic probe with variable power disperses agglomerated materials to ensure consistent sample dispersion during measurements.

Versatility

Users can program, save and recall unlimited SOP routines for fill, disperse, measure, rinse and run commands.

Connectivity

A separate fill pump allows the user to connect to any water or solvent source. The recirculator fills, de-aerates, auto-dilutes and pre-circulates automatically.



Auto Dispersion

The FlowSync's fluid dynamics feature a built-in turbulence to ensure that all particles are moving constantly within the flow, negating the need for an external stirrer.

Self-Cleaning

The wash feature in the sample vessel ensures the walls of the vessel are thoroughly cleaned during the 'rinse' cycle. This eliminates 'carry-over' of material during repeated measurements.

Quick Connect

The FlowSync features a one-step smart disconnect/connect mechanism. Changing from wet to dry analysis mode requires no complicated wiring or tubing reconnection. Simply disengage one sample module and engage the other.



TurboSync: Dry Delivery System

The TurboSync's primary function is to deliver a properly dispersed sample to the measuring cell, allowing for consistent and repeatable particle size analyses of dry powders.

Flexibility

Compressed air and flow conditions settings allow the operator to achieve optimal dispersion usually associated with fluid dispersal systems for highly agglomerated materials such as alumina. Dispersion conditions can be fine-tuned for measurement of the most fragile materials.

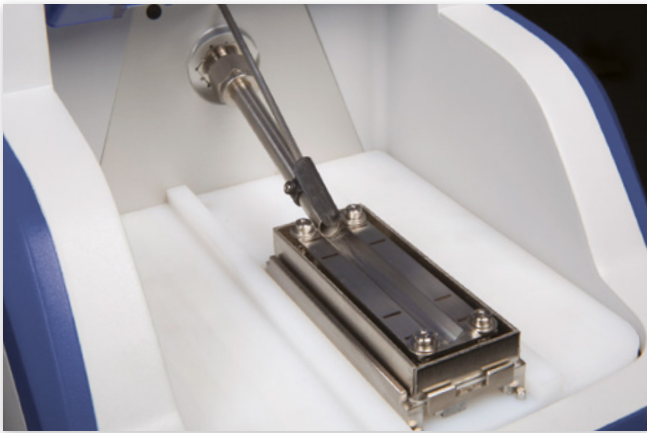

Small Sample Volumes

Sample volumes can be as small as 0.1 cc. Ideal for applications where the sample is expensive to produce or produced in small volumes.

Rapid Measurements

Measurement time is typically 10 seconds with the TurboSync autoscan.

Automatic Sampling

The Microtrac FLEX software facilitates programming of measurement cycles. Simply place the sample in the sample tray and press RUN. All data is saved on the system PC or can be exported to user networks or LIMS systems.

Repeatability

Consistent control of aspiration settings deliver excellent sample-to-sample and bench-to-bench repeatability.

Quick Connect

The TurboSync features a one-step smart disconnect / connect mechanism. Changing from wet to dry analysis mode requires no complicated wiring or tubing reconnection. Simply disengage one sample module and engage the other.



FLEX: Integrating Powerful LD & DIA Software

It only seemed appropriate that Microtrac named our powerful, flexible, easy-to-use software FLEX. Designed with the end-user in mind, FLEX allows the operators to measure, recall, validate, export and print their analysis effortlessly.

How it works

FLEX software takes all the guesswork out of the analysis. Simply load your material, establish your measurement SOP and the Microtrac Auto Sequence feature takes care of the rest. Users can also set up SOP libraries that save important information such as material, refractive index, fluids, dispersion settings and pump speed that can be recalled at any time, saving users from tedious data entry.

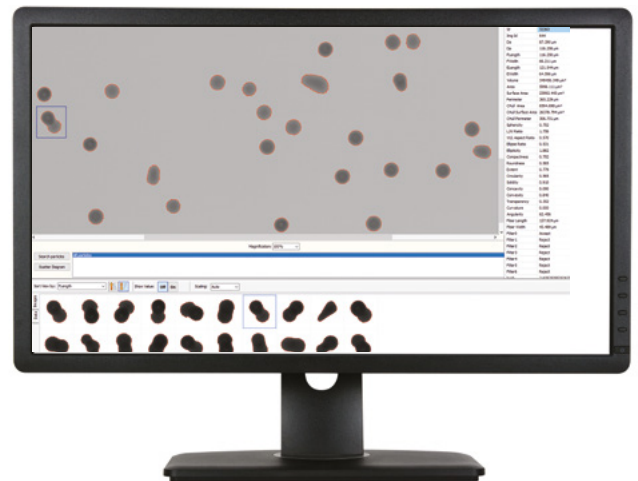

Manage your data

Like taking a deeper dive into your data? FLEX gives you the option to either export your data to your preferred statistical analysis package or to use ours. Operators can also review a previous measurement with our database recall function.

FLEX features

Data Tolerance: Set Pass / Fail alerts when your material deviates from upper and lower size limits, ideal for quality control applications.

Trending: Ability to trend individual size parameters over a specific time period or material type.

Tailored Reports: Use customisable reports to present your data the way you want to see it.

Security / Data Protection: Easy to set up and administer password protected security settings including electronic signatures.

Compliance: FLEX is fully compliant per FDA 21 CFR Part 11 guidelines.

Enhanced Size & Shape Capabilities

FLEX, Microtrac's easy to use software for Sync, now integrates instrument control and reporting for both laser diffraction and dynamic image analysis in one graphical user interface. FLEX enables users to measure, recall, validate, export and print their analysis effortlessly. Through the use of SOPs, users can set up libraries with their analysis settings, material, fluids, dispersion settings, pump speed and imaging parameters - simplifying analysis procedures and ensuring consistency from run to run.

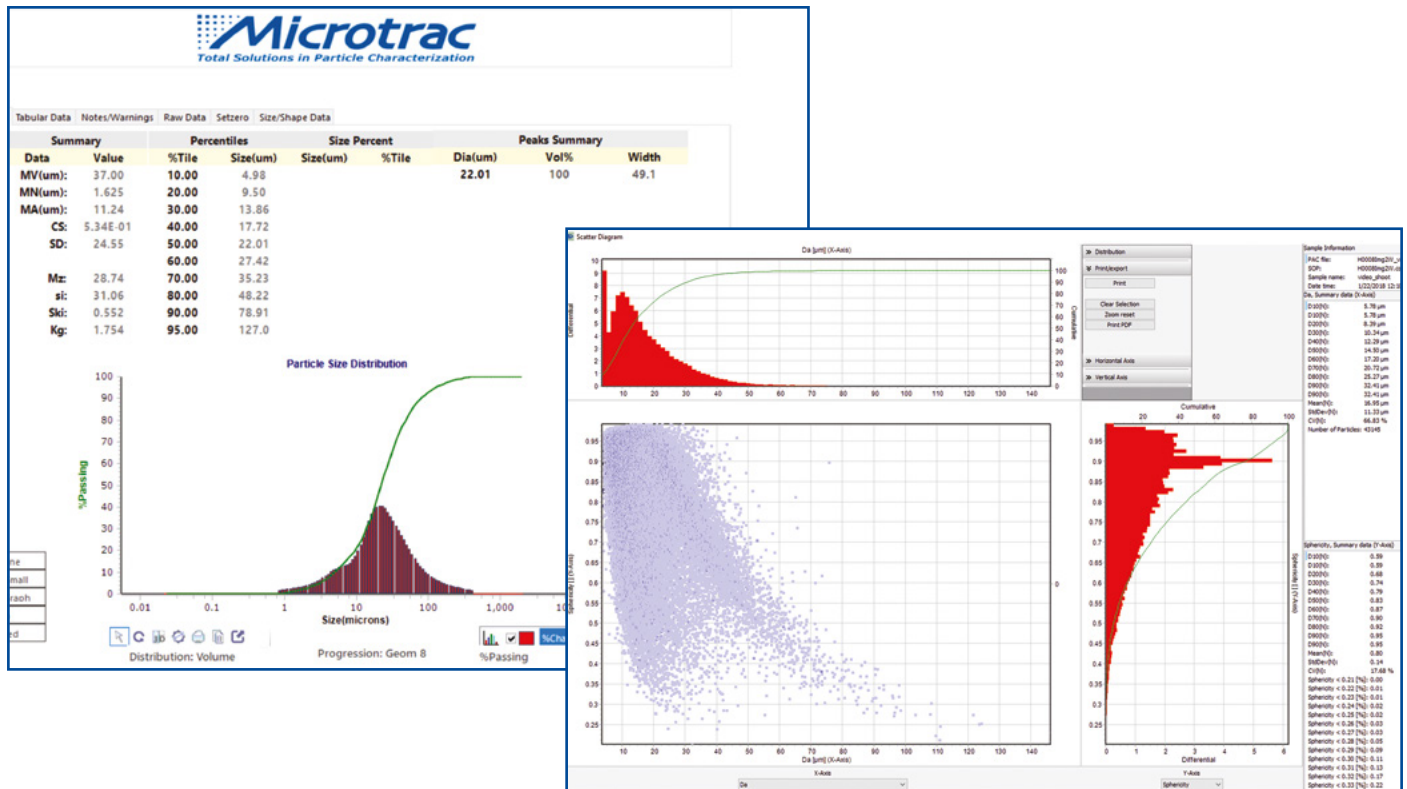

In addition to particle size distributions from laser diffraction, FLEX now integrates key features from dynamic image analysis including:

- Reporting of graphical and tabular sizes and shapes
- Displays position of every particle relative to X & Y axis selected parameters
- Realtime visualisation of particles during measurement & data recall
- Over 30 size & shape summary parameters for each measurement & individual particles
- Zoom in and inspect individual particles
- Search and filter function allows you to zero-in on an area of interest
- Innovative LD / DIA blend feature in algorithm produces accurate particle size distributions up to 4000 microns

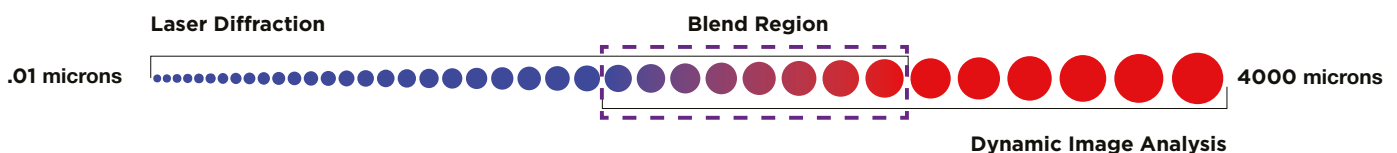

Applications

Metal Powders

Industrial Minerals

Ceramics

Glass Beads

Batteries

Oil & Gas

Chemicals

Paints / Pigments

Pharmaceuticals

Coatings

Cement

3D Printing



Much More!

Features

- Integrates the world's leading laser diffraction and dynamic image analysis technology in one instrument
- Synchronous size and shape analysis
- Fast and easy switch between wet and dry systems - click and go
- Advanced design for unsurpassed dispersion of wet or dry material
- Easy to use, integrated DIA and LD FLEX software
- Powerful reporting that integrates particle size and shape data
- Small bench footprint

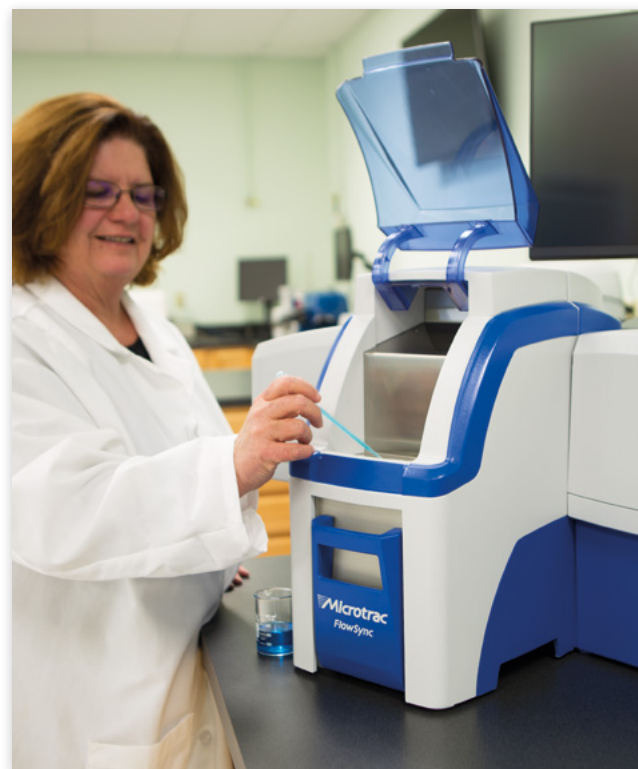

Key Benefits

- Significantly reduced troubleshooting time when particle size is not what is expected
- View Particles allows users to see particles and qualify more thoroughly than ever before
- Particle shape does impact particle performance and can change - users can now define their product in a more detailed and useful way utilising both size and shape parameters
- Ease of use and ease of changeover from wet to dry enables sites with multiple users to just click and go when running different materials - no learning curve and with SOPs, no setup time
- Same sample, same bench, same flow path, same sample cell - one run yields PSD with more than 30 size and shape parameters
- Optimise quality control by adding shape to your size specifications

Specifications

Measuring Range	0.01 to 4000 microns
Precision*	Spherical glass beads D50 = 642 microns, precision as CV = 0.7% Spherical glass beads D50 = 57 microns, precision as CV = 1.0% Spherical latex beads D50 = 0.4 microns, precision as CV = 0.6%
Laser Class	Red 780 nm, blue 405 nm - class 1 laser product per 21 CFR 1040.10 & IEC60825-1
Laser Power	Red laser 3 mW nominal; blue lasers 4-8 mW nominal
Detection System	Two fixed photo-electric detectors with logarithmically spaced segments are placed at correct angles for optimal scattered light detection from 0.02 to 163 degrees using 151 detector segments.
Data Handling	Volume, number and area distributions as well as percentile and other summary data. Data is stored in ODBC format in encrypted Microsoft Access Databases to ensure compatibility with external statistical software applications. Data integrity may be ensured using FDA 21 CFR Part 11 compliant security features including password protection, electronic signatures and assignable permissions.
Typical Analysis Time	10 to 30 seconds
Electrical	AC input: 90 – 264 VAC, 47 - 63 Hz, single phase
Power Consumption	25 W nominal, 50 W max., depending on options installed
Environmental	Temperature: 5° to 40° Celsius (50° to 95° Fahrenheit) Humidity: 90% RH, non- condensing maximum Storage Temperature: -10° to 50° Celsius (14° to 122° Fahrenheit) (dry only) Pollution: Degree 2
Compliance	ISO 13320 Laser Diffraction, ISO 13322 Imaging, ISO 9276-6 Representation of results of particle size analysis
Image Analysis	5.2 megapixel (2560 x 2048), 22 fps at max resolution
Wet Operation	Volume: 200 ml nominal Flow rate: 0 bis 65 ml/sek with water Inlet pressure: 50 psig (345 kPa) maximum
Dry Operation	100 psi (689 kPa) maximum pressure 5 CFM (8,5 m ³ /h) at 50 psi (345 kPa) minimum flow rate Free of dry contaminants, moisture and oil.
Vacuum	Vacuum must meet or exceed 50 CFM (85 m ³ /h)
Physical Specifications	Case Material: Impact resistant plastic Exterior surfaces are finished with corrosion resistant paint or plating Chemical Compatibility: Class I
Dimensions	46H x 82W x 50D cm (18,1H x 32,3W x 19,7D in)
Weight	FlowSync: 19,5kg (43lbs); TurboSync: 13,6kg (30lbs); Sync: 23,6kg (50,8lbs)

*Depending on sample material and sample preparation

Contact:

Europe: +49 2151 361-389-0

USA: 1-888-643-5880

www.microtrac.com

Microtrac
Total Solutions in Particle Characterization

