

|  |  |  |  |                 |  |
|--|--|--|--|-----------------|--|
|  |  |  |  | Datum           | Durchlauf-Sohlenreiniger ECO<br>Bürstenlänge: 400 mm |
|  |  |  |  | 18.06.2010      |  |
|  |  |  |  |                 |  |
|  |  |  |  |                 |  |
|  |  |  |  |                 |  |
|  |  |  |  |                 |  |
|  |  |  |  | Masse: 90.25 kg | Masstab: 1:25  |

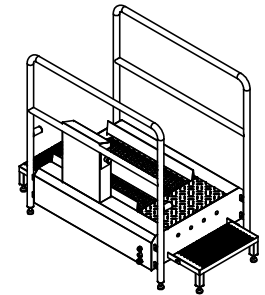

|  |  |  |  |                  |  |
|--|--|--|--|------------------|--|
|  |  |  |  | Datum            | Durchlauf-Sohlenreiniger ECO<br>Bürstenlänge: 700 mm |
|  |  |  |  | 13.02.2013       |  |
|  |  |  |  |                  |  |
|  |  |  |  |                  |  |
|  |  |  |  |                  |  |
|  |  |  |  |                  |  |
|  |  |  |  | Masse: 126.68 kg | Masstab: 1:30  |

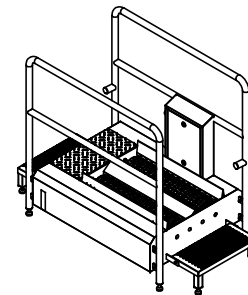
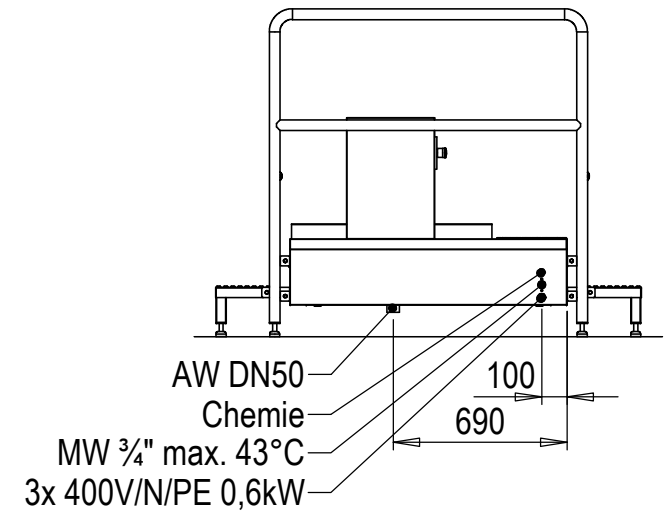
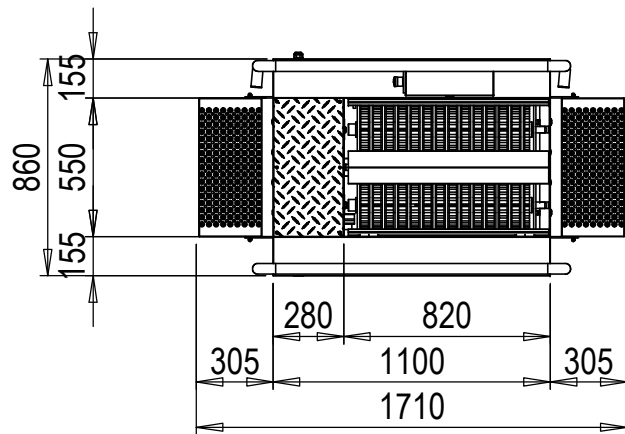
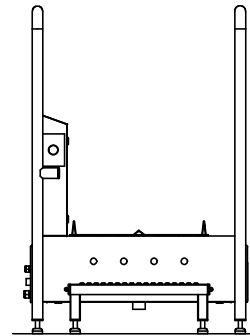
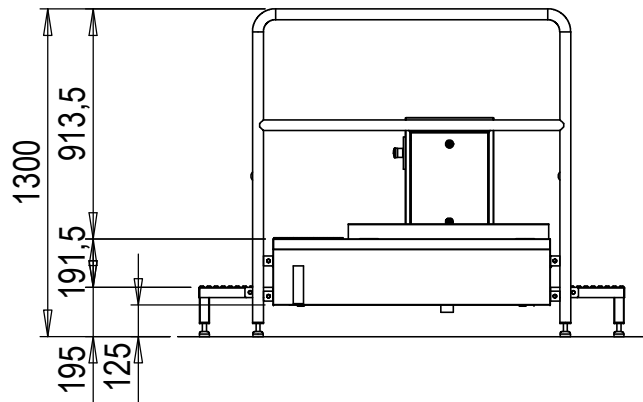
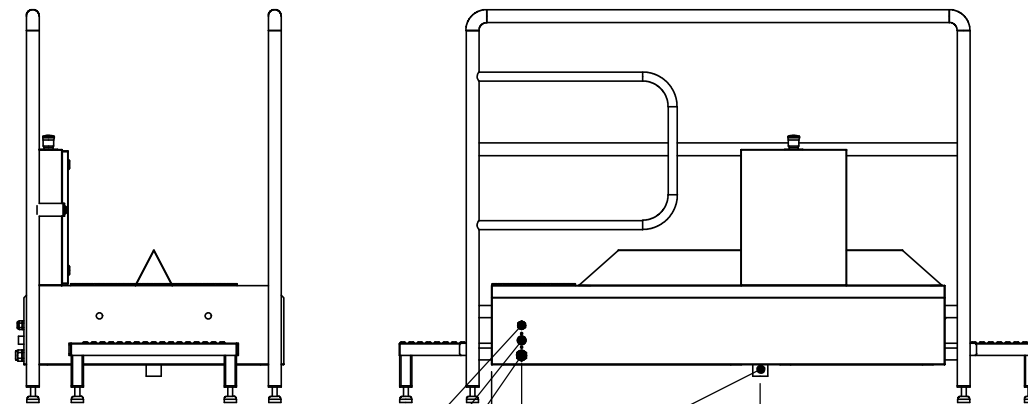
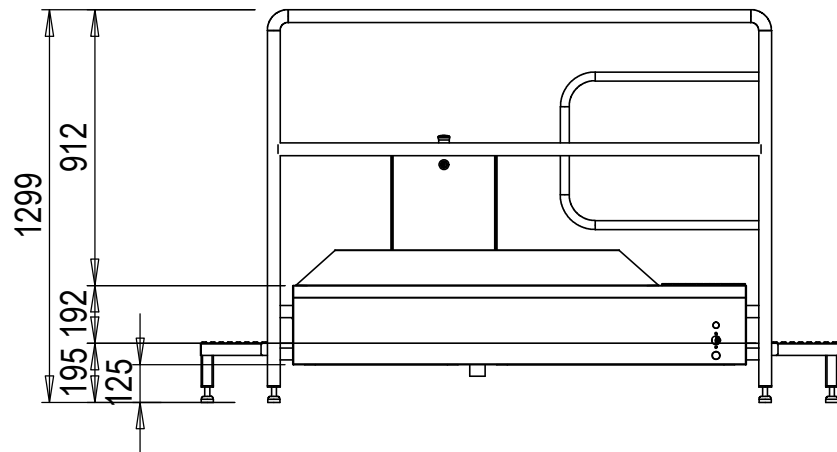

Chemie  
 Wasser 3/4" max 43°C  
 3x 400V/N/PE  
 Abwasser DN50

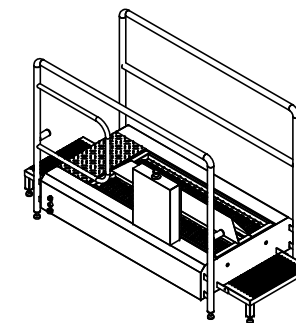
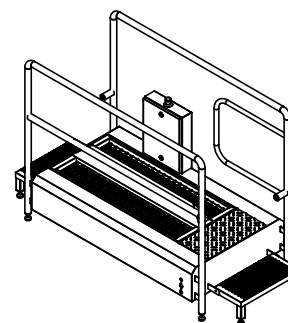
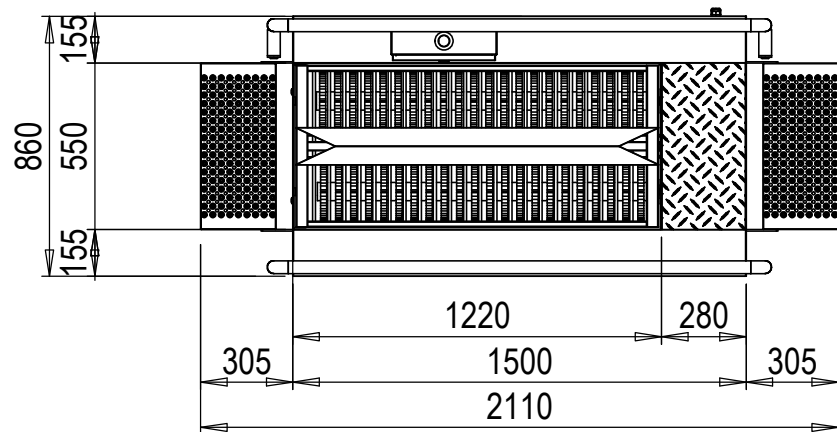
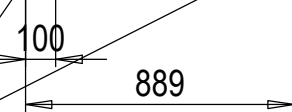

|  |  |  |  |                  |   |
|--|--|--|--|------------------|---|
|  |  |  |  | Datum            | Durchlauf-Sohlenreiniger ECO<br>Bürstenlänge: 1100 mm |
|  |  |  |  | 26.02.2010       |   |
|  |  |  |  |                  |   |
|  |  |  |  |                  |   |
|  |  |  |  |                  |   |
|  |  |  |  |                  |   |
|  |  |  |  |                  |   |
|  |  |  |  | Masse: 135.34 kg | Massstab: 1:25  |