

MDT 219 J8

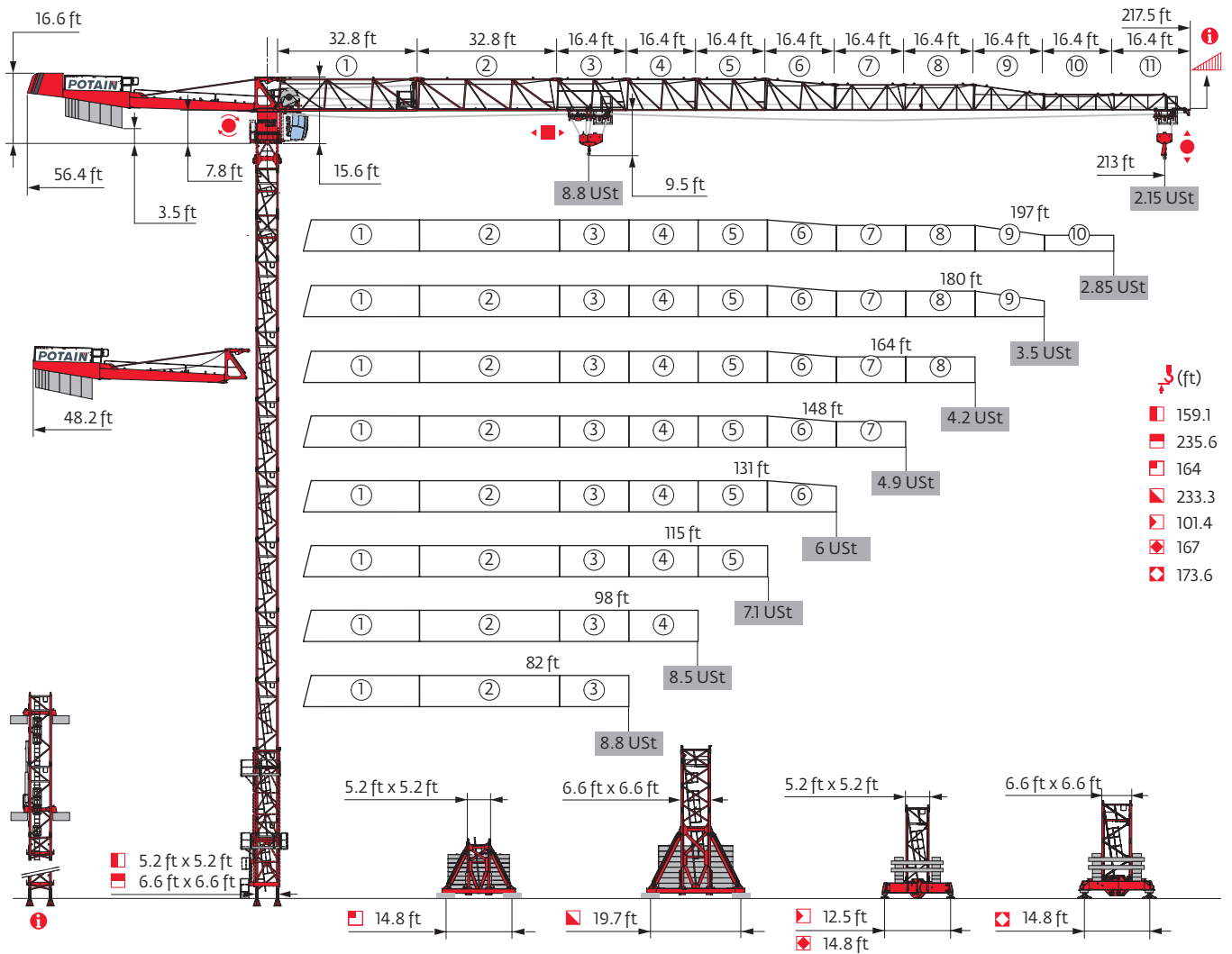

Mast - Reactions

5.2 ft City - ZC 4230 -

Height (ft)	82	98	115	131	148	164	180	197	213
(ft)	101.4	79.4	101.4	101.4	101.4	95.8	95.8	101.4	101.4
/P+ (ft)	101.4	-	-	-	-	95.8	95.8	101.4	101.4
	10.9 ft	0	1	0	0	1	1	0	0
	16.4 ft	6	4	6	6	5	5	6	6
FI (Ust)	● 71	70	74	74	75	76	76	78	78
	■ 57	58	58	58	58	58	55	56	59

5.2 ft City - ZD 4230 -

Height (ft)	82	98	115	131	148	164	180	197	213
(ft)	150.6	150.6	155.8	150.6	150.6	150.6	145	145	145
/P+ (ft)	150.6	145	150.6	150.6	150.6	150.6	145	145	145
	10.9 ft	0	0	2	0	0	1	1	1
	16.4 ft	9	9	8	9	9	8	8	8
FI (Ust)	● 76	78	79	83	83	81	81	82	83
	■ 71	71	77	74	75	76	75	78	80

5.2 ft City - ZD 463 -

Height (ft)	82	98	115	131	148	164	180	197	213
(ft)	167	167	167	161.4	161.4	155.8	150.6	155.8	155.8
/P+ (ft)	167	161.4	161.4	161.4	161.4	155.8	150.6	155.8	155.8
	10.9 ft	0	0	1	1	2	0	2	2
	16.4 ft	10	10	10	9	8	9	8	8
FI (Ust)	● 82	84	85	86	88	84	84	88	89
	■ 84	84	85	83	85	81	79	88	93

5.2 ft - P 41A

Height (ft)	82	98	115	131	148	164	180	197	213
(ft)	159.1	159.1	159.1	153.5	153.5	148	148	148	148
/P+ (ft)	159.1	159.1	159.1	153.5	153.5	148	148	148	148
	6.6 ft	1	1	1	1	1	1	1	1
	10.9 ft	2	2	2	0	0	1	1	1
	16.4 ft	8	8	8	9	9	8	8	8
F2 (Ust)	● 132	148	148	144	144	136	140	142	144
	■ 159	159	162	150	153	145	153	161	168
F3 (Ust)	● 98	112	111	108	107	99	103	105	106
	■ 130	127	130	118	120	113	120	127	135

5.2 ft - S 41A -

Height (ft)	82	98	115	131	148	164	180	197	213
(ft)	164	164	164	164	158.5	158.5	152.9	152.9	152.9
/P+ (ft)	164	164	164	164	158.5	158.5	152.9	152.9	152.9
	6.6 ft	1	1	1	1	1	1	1	1
	10.9 ft	0	0	0	0	1	1	2	2
	16.4 ft	9	9	9	9	8	8	7	7
FI (Ust)	● 84	90	90	91	90	88	89	89	90
	■ 91	90	92	93	89	90	90	94	99

5.2 ft - ZD 4230 -

Height (ft)	82	98	115	131	148	164	180	197	213
(ft)	146	146	146	146	146	146	140.8	140.8	140.8
/P+ (ft)	146	129.6	129.6	140.8	146	146	140.8	140.8	140.8
	6.6 ft	1	1	1	1	1	1	1	1
	10.9 ft	2	2	2	2	2	0	0	0
	16.4 ft	7	7	7	7	7	8	8	8
FI (Ust)	● 76	79	79	79	84	82	82	82	83
	■ 75	75	76	77	79	79	77	80	84

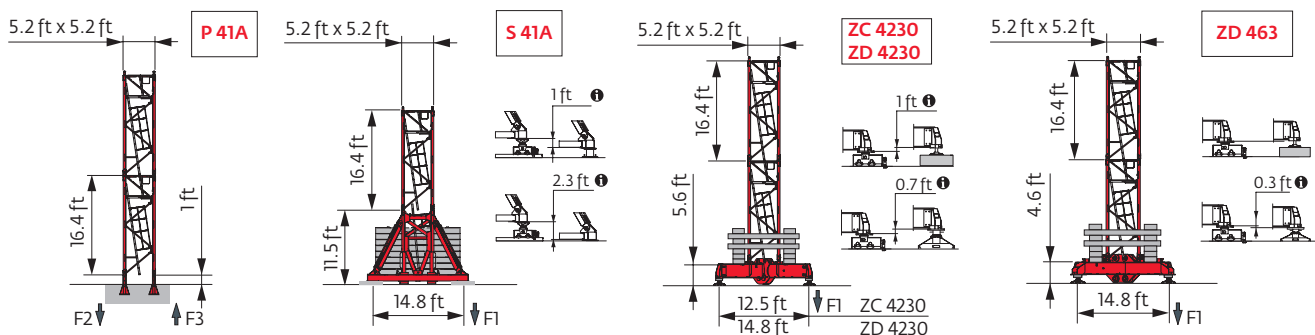



6.6 ft - P 602B

Height (ft)	82	98	115	131	148	164	180	197	213	
Height (ft)	235.6	235.6	235.6	230	230	230	230	224.7	219.2	
Height/P ₊ (ft)	235.6	235.6	235.6	230	230	230	230	224.7	219.2	
	6.6 ft	1	1	1	1	1	1	1	1	
	10.9 ft	0	0	0	1	1	1	2	0	
	16.4 ft	14	14	14	13	13	13	12	13	
F2 (Ust)	●	170	176	177	175	177	177	182	179	175
	■	336	335	338	327	330	331	338	331	320
F3 (Ust)	●	126	132	131	129	130	129	133	131	128
	■	296	295	297	285	287	288	293	287	277

6.6 ft - V 60A - 

Height (ft)	82	98	115	131	148	164	180	197	213
Height (ft)	211.3	211.3	211.3	211.3	211.3	211.3	206	206	200.5
Height/P ₊ (ft)	211.3	211.3	211.3	211.3	211.3	211.3	206	206	200.5
	6.6 ft	1	1	1	1	1	1	1	1
	10.9 ft	1	1	1	1	1	2	2	0
	16.4 ft	11	11	11	11	11	10	10	11
F1 (Ust)	●	100	102	103	104	105	105	105	104
	■	144	144	145	146	147	148	145	144

6.6 ft - V 63A - 

Height (ft)	82	98	115	131	148	164	180	197	213
Height (ft)	233.3	233.3	233.3	233.3	233.3	233.3	233.3	228	228
Height/P ₊ (ft)	233.3	233.3	233.3	233.3	233.3	233.3	233.3	228	228
	6.6 ft	1	1	1	1	1	1	1	1
	10.9 ft	0	0	0	0	0	0	1	1
	16.4 ft	12	12	12	12	12	12	11	11
F1 (Ust)	●	120	122	122	123	124	125	125	126
	■	179	178	180	181	182	183	186	187

6.6 ft - ZD 463 - 

Height (ft)	82	98	115	131	148	164	180	197	213
Height (ft)	173.6	173.6	173.6	173.6	173.6	173.6	168	162.4	162.4
Height/P ₊ (ft)	173.6	173.6	173.6	173.6	173.6	173.6	168	162.4	162.4
	6.6 ft	1	1	1	1	1	1	1	1
	10.9 ft	0	0	0	0	0	1	2	2
	16.4 ft	10	10	10	10	10	9	8	8
F1 (Ust)	●	100	104	104	105	105	104	103	104
	■	132	130	132	133	135	132	130	135

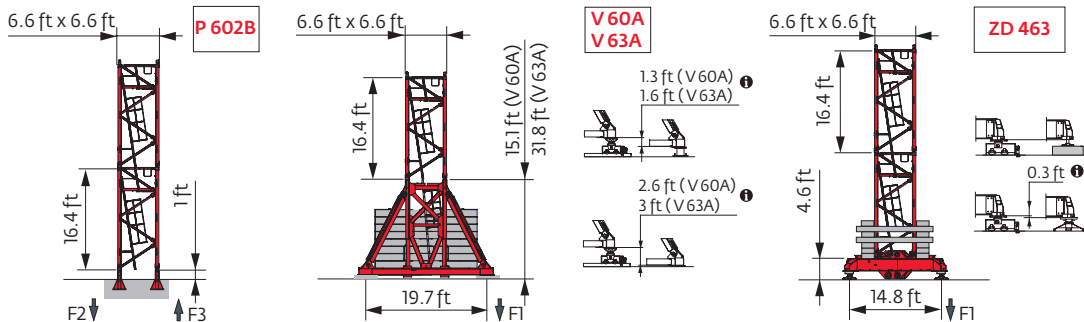

Note: When "ASCE" is noted in this data sheet it is referring to 115 mph Wind Zone, Exposure B, Design Wind Speed = 98 mph. See back cover for design wind speed calculations.

i Motorized accesses of Cab-IN and TCL types: Adapted mast compositions, base ballast and reactions.

Anchorage

i

Base ballast

USt / 5.2 ft City - ZC 4230

ft	82	98	115	131	148	164	180	197	213
101.4	88.2		88.2	88.2	88.2			88.2	88.2
95.8	88.2		88.2	88.2	88.2	88.2	88.2	88.2	88.2
90.6	88.2		88.2	88.2	88.2	88.2	88.2	88.2	88.2
85	88.2		88.2	88.2	88.2	88.2	88.2	88.2	88.2
79.4	88.2	88.2	88.2	88.2	88.2	88.2	88.2	88.2	88.2
63	88.2	88.2	88.2	88.2	88.2	88.2	88.2	88.2	88.2

USt / 5.2 ft City - ZD 463

ft	82	98	115	131	148	164	180	197	213
167	99.2	99.2	99.2						
161.4	99.2	99.2	93.7	93.7	99.2				
155.8	93.7	93.7	93.7	93.7	93.7	93.7		99.2	99.2
150.6	88.2	93.7	88.2	88.2	88.2	88.2	93.7	93.7	93.7
134.2	71.7	88.2	88.2	82.7	82.7	71.7	77.2	77.2	71.7
117.8	60.6	88.2	82.7	82.7	77.2	66.1	60.6	60.6	60.6
101.4	60.6	88.2	82.7	82.7	77.2	60.6	60.6	55.1	60.6
85	60.6	88.2	82.7	82.7	77.2	60.6	60.6	55.1	55.1
68.6	60.6	88.2	82.7	82.7	77.2	60.6	60.6	55.1	55.1
52.2	60.6	88.2	82.7	82.7	77.2	60.6	60.6	55.1	55.1

USt / 5.2 ft - ZD 4230

ft	82	98	115	131	148	164	180	197	213
146	93.7	93.7	93.7	93.7	93.7	93.7			
140.8	88.2	88.2	88.2	93.7	93.7	88.2	93.7	93.7	93.7
124.3	77.2	93.7	93.7	88.2	82.7	77.2	77.2	77.2	77.2
107.9	77.2	88.2	82.7	82.7	77.2	77.2	77.2	77.2	77.2
91.5	77.2	88.2	82.7	82.7	77.2	77.2	77.2	77.2	77.2
75.1	77.2	88.2	82.7	82.7	77.2	77.2	77.2	77.2	77.2
58.7	77.2	88.2	82.7	82.7	77.2	77.2	77.2	77.2	77.2

USt / 6.6 ft - V 63A

ft	82	98	115	131	148	164	180	197	213
233.3	198.4	198.4	198.4	198.4	198.4	198.4	198.4		
228	185.2	185.2	185.2	185.2	185.2	185.2	185.2	198.4	198.4
211.6	158.7	158.7	158.7	158.7	158.7	158.7	158.7	158.7	172
195.2	119.1	119.1	119.1	119.1	119.1	119.1	132.3	132.3	132.3
178.8	92.6	92.6	92.6	92.6	92.6	92.6	92.6	105.8	105.8
162.4	66.1	66.1	66.1	66.1	66.1	66.1	66.1	79.4	79.4
146	52.9	52.9	52.9	52.9	52.9	52.9	52.9	52.9	52.9
129.6	52.9	52.9	39.7	39.7	39.7	39.7	52.9	39.7	39.7
113.2	39.7	39.7	39.7	39.7	39.7	39.7	39.7	39.7	39.7
96.8	26.5	39.7	39.7	39.7	39.7	26.5	26.5	26.5	39.7
80.4	26.5	39.7	39.7	39.7	39.7	26.5	26.5	26.5	39.7
64	26.5	39.7	39.7	39.7	39.7	26.5	26.5	26.5	39.7

USt / 5.2 ft City - ZD 4230

ft	82	98	115	131	148	164	180	197	213
155.8			93.7						
150.6	93.7	93.7	93.7	93.7	93.7	93.7			
145	88.2	93.7	93.7	93.7	88.2	88.2	93.7	93.7	93.7
128.6	71.7	93.7	88.2	88.2	88.2	77.2	77.2	77.2	71.7
112.2	66.1	88.2	88.2	82.7	82.7	66.1	66.1	66.1	66.1
95.8	66.1	88.2	88.2	82.7	82.7	66.1	60.6	60.6	60.6
79.4	66.1	88.2	88.2	82.7	82.7	66.1	60.6	60.6	60.6
63	66.1	88.2	88.2	82.7	82.7	66.1	60.6	60.6	60.6

USt / 5.2 ft - S 41A

ft	82	98	115	131	148	164	180	197	213
164	105.8	105.8	105.8	105.8					
158.5	105.8	105.8	105.8	105.8	105.8	105.8			
152.9	99.2	99.2	99.2	99.2	99.2	99.2	105.8	105.8	105.8
136.5	86	99.2	92.6	92.6	92.6	86	86	86	86
120.1	72.8	92.6	86	86	86	72.8	72.8	72.8	72.8
103.7	59.5	86	79.4	79.4	72.8	66.1	59.5	59.5	66.1
87.3	59.5	86	79.4	79.4	72.8	59.5	59.5	52.9	59.5
70.9	59.5	86	79.4	79.4	72.8	59.5	59.5	52.9	59.5
54.5	59.5	86	79.4	79.4	72.8	59.5	59.5	52.9	59.5

USt / 6.6 ft - V 60A

ft	82	98	115	131	148	164	180	197	213
211.3	145.5	145.5	145.5	145.5	145.5	145.5			
206	145.5	145.5	145.5	145.5	145.5	145.5	145.5	145.5	
200.5	132.3	132.3	132.3	132.3	132.3	132.3	132.3	132.3	145.5
184.1	105.8	92.6	105.8	105.8	105.8	92.6	105.8	105.8	119.1
167.7	79.4	66.1	66.1	66.1	66.1	66.1	79.4	79.4	92.6
151.3	66.1	66.1	52.9	52.9	52.9	52.9	66.1	66.1	66.1
134.8	52.9	52.9	52.9	52.9	52.9	52.9	52.9	52.9	52.9
118.4	39.7	52.9	52.9	39.7	39.7	39.7	39.7	39.7	39.7
102	26.5	52.9	52.9	39.7	39.7	26.5	26.5	26.5	39.7
85.6	26.5	52.9	52.9	39.7	39.7	26.5	26.5	26.5	39.7
69.2	26.5	52.9	52.9	39.7	39.7	26.5	26.5	26.5	39.7
52.8	26.5	52.9	52.9	39.7	39.7	26.5	26.5	26.5	39.7

USt / 6.6 ft - ZD 463

ft	82	98	115	131	148	164	180	197	213
173.6	137.8	132.3	132.3	132.3	132.3	132.3			
168	121.3	121.3	121.3	121.3	121.3	121.3	126.8		
162.4	110.2	110.2	110.2	110.2	110.2	110.2	115.7	126.8	132.3
146	93.7	93.7	88.2	93.7	93.7	93.7	99.2	99.2	99.2
129.6	77.2	82.7	82.7	77.2	77.2	77.2	77.2	77.2	77.2
113.2	60.6	82.7	82.7	77.2	71.7	60.6	60.6	60.6	60.6
97.1	55.1	82.7	82.7	77.2	71.7	60.6	55.1	55.1	55.1
80.7	55.1	82.7	82.7	77.2	71.7	60.6	55.1	55.1	55.1
64.3	55.1	82.7	82.7	77.2	71.7	60.6	55.1	55.1	55.1

Load curves



▲▲▲▲ (ft)		56	66	72	82	89	98	105	115	121	131	138	148	154	164	171	180	187	197	203	213	ft	
▲▲▲▲	8.8 USt	▲▲▲▲										▲▲▲▲											
▲▲▲▲	4.4 USt	▲▲▲▲										▲▲▲▲											
213	10 → 66	120 - 129	8.8	8.8	8.1	7	6.4	5.7	5.3	4.7	4.4	4.3	4	3.7	3.5	3.2	3	2.8	2.65	2.45	2.3	2.15	USt
	10 → 72	122 - 131	8.8	8.8	8.8	7.6	6.8	6	5.4	4.8	4.4	4.4	4.1	3.8	3.6	3.3	3.1	2.95	2.8	2.55	2.35	2.15	USt P+
197	10 → 72	129 - 138	8.8	8.8	8.7	7.6	7	6.2	5.7	5.1	4.8	4.4	4.4	4	3.8	3.6	3.4	3.2	3	2.85	2.85	2.3	USt
	10 → 76	130 - 138	8.8	8.8	8.8	8.1	7.4	6.5	5.9	5.3	4.8	4.4	4.4	4.1	3.9	3.6	3.4	3.2	3	2.85	2.85	2.3	USt P+
180	10 → 77	137 - 146	8.8	8.8	8.8	8.2	7.5	6.7	6.2	5.6	5.2	4.7	4.4	4.4	4.1	3.8	3.7	3.4	3.4	3.4	3.4	3.4	USt
	10 → 81	138 - 148	8.8	8.8	8.8	8.6	7.9	7	6.4	5.7	5.2	4.7	4.4	4.4	4.2	3.9	3.7	3.5	3.5	3.5	3.5	3.5	USt P+
164	10 → 82	146 - 154	8.8	8.8	8.8	8.8	8	7.2	6.7	6	5.6	5.1	4.8	4.4	4.4	4.2	4.2	4.2	4.2	4.2	4.2	4.2	USt
	10 → 84	147 - 157	8.8	8.8	8.8	8.8	8.3	7.4	6.9	6.2	5.7	5.2	4.8	4.4	4.4	4.2	4.2	4.2	4.2	4.2	4.2	4.2	USt P+
148	10 → 83		8.8	8.8	8.8	8.8	8.2	7.3	6.7	6.1	5.7	5.2	4.9	4.5	4.5	4.5	4.5	4.5	4.5	4.5	4.5	4.5	USt
	10 → 90		8.8	8.8	8.8	8.8	8.8	8	7.4	6.7	6.2	5.6	5.2	4.8	4.8	4.8	4.8	4.8	4.8	4.8	4.8	4.8	USt P+
131	10 → 84		8.8	8.8	8.8	8.8	8.3	7.4	6.9	6.2	5.8	5.3	5.3	5.3	5.3	5.3	5.3	5.3	5.3	5.3	5.3	5.3	USt
	10 → 92		8.8	8.8	8.8	8.8	8.8	8.1	7.6	6.8	6.4	5.9	5.9	5.9	5.9	5.9	5.9	5.9	5.9	5.9	5.9	5.9	USt P+
115	10 → 85		8.8	8.8	8.8	8.8	8.5	7.5	7	6.3	5.9	5.9	5.9	5.9	5.9	5.9	5.9	5.9	5.9	5.9	5.9	5.9	USt
	10 → 93		8.8	8.8	8.8	8.8	8.8	8.3	7.7	7	6.3	5.9	5.9	5.9	5.9	5.9	5.9	5.9	5.9	5.9	5.9	5.9	USt P+
98	10 → 87		8.8	8.8	8.8	8.8	8.6	7.7	7.1	6.4	6.1	5.7	5.7	5.7	5.7	5.7	5.7	5.7	5.7	5.7	5.7	5.7	USt
	10 → 95		8.8	8.8	8.8	8.8	8.8	8.4	7.7	7.1	6.4	6.1	5.7	5.7	5.7	5.7	5.7	5.7	5.7	5.7	5.7	5.7	USt P+
82	10 → 82		8.8	8.8	8.8	8.8	8.8	8.8	8.8	8.8	8.8	8.8	8.8	8.8	8.8	8.8	8.8	8.8	8.8	8.8	8.8	8.8	USt
	10 → 82		8.8	8.8	8.8	8.8	8.8	8.8	8.8	8.8	8.8	8.8	8.8	8.8	8.8	8.8	8.8	8.8	8.8	8.8	8.8	8.8	USt P+

$W = W - 0.41 \text{ USt max.}$



▲▲▲▲ (ft)		56	66	72	82	89	98	105	115	121	131	138	148	154	164	171	180	187	197	203	213	ft	
▲▲▲▲	8.8 USt	▲▲▲▲										▲▲▲▲											
▲▲▲▲	4.4 USt	▲▲▲▲										▲▲▲▲											
213	8 → 67	122 - 125	8.8	8.8	8.2	7.1	6.5	5.8	5.4	4.8	4.5	4.1	3.8	3.5	3.3	3	2.8	2.6	2.45	2.25	2.05	1.95	USt
	8 → 73	124 - 126	8.8	8.8	8.8	7.7	6.9	6.1	5.5	4.9	4.5	4.2	3.9	3.6	3.4	3.1	2.95	2.75	2.6	2.4	2.2	1.95	USt P+
197	8 → 72	131 - 132	8.8	8.8	8.8	7.7	7.1	6.3	5.8	5.2	4.9	4.4	4.2	3.8	3.6	3.3	3.2	2.95	2.85	2.65	2.65	2.65	USt
	8 → 77	132 - 135	8.8	8.8	8.8	8.2	7.5	6.6	6	5.3	4.9	4.5	4.3	3.9	3.7	3.4	3.2	3	2.85	2.7	2.7	2.7	USt P+
180	8 → 78	139 - 141	8.8	8.8	8.8	8.3	7.6	6.8	6.3	5.7	5.3	4.8	4.5	4.2	3.9	3.6	3.4	3.2	3.2	3.2	3.2	3.2	USt
	8 → 81	140 - 143	8.8	8.8	8.8	8.7	8	7.1	6.5	5.8	5.3	4.8	4.5	4.3	4	3.7	3.5	3.3	3.3	3.3	3.3	3.3	USt P+
164	8 → 82	149 - 151	8.8	8.8	8.8	8.8	8.1	7.3	6.8	6.1	5.7	5.2	4.9	4.4	4.3	4	4.2	4.2	4.2	4.2	4.2	4.2	USt
	8 → 85	149 - 151	8.8	8.8	8.8	8.8	8.4	7.5	7	6.2	5.8	5.2	4.9	4.5	4.3	4.1	4.1	4.1	4.1	4.1	4.1	4.1	USt P+
148	8 → 83		8.8	8.8	8.8	8.8	8.3	7.4	6.8	6.2	5.8	5.3	5	4.6	4.6	4.6	4.6	4.6	4.6	4.6	4.6	4.6	USt
	8 → 91		8.8	8.8	8.8	8.8	8.8	8.1	7.5	6.8	6.3	5.7	5.3	4.9	4.9	4.9	4.9	4.9	4.9	4.9	4.9	4.9	USt P+
131	8 → 85		8.8	8.8	8.8	8.8	8.4	7.5	7	6.3	5.9	5.4	5.4	5.4	5.4	5.4	5.4	5.4	5.4	5.4	5.4	5.4	USt
	8 → 93		8.8	8.8	8.8	8.8	8.8	8.2	7.7	6.9	6.5	6	6	6	6	6	6	6	6	6	6	6	USt P+
115	8 → 86		8.8	8.8	8.8	8.8	8.6	7.6	7.1	6.4	6.1	5.7	5.7	5.7	5.7	5.7	5.7	5.7	5.7	5.7	5.7	5.7	USt
	8 → 94		8.8	8.8	8.8	8.8	8.8	8.4	7.8	7.1	6.4	6.1	5.7	5.7	5.7	5.7	5.7	5.7	5.7	5.7	5.7	5.7	USt P+
98	8 → 88		8.8	8.8	8.8	8.8	8.7	7.8	7.1	6.4	6.1	5.7	5.7	5.7	5.7	5.7	5.7	5.7	5.7	5.7	5.7	5.7	USt
	8 → 96		8.8	8.8	8.8	8.8	8.8	8.5	7.8	7.1	6.4	6.1	5.7	5.7	5.7	5.7	5.7	5.7	5.7	5.7	5.7	5.7	USt P+
82	8 → 82		8.8	8.8	8.8	8.8	8.8	8.8	8.8	8.8	8.8	8.8	8.8	8.8	8.8	8.8	8.8	8.8	8.8	8.8	8.8	8.8	USt
	8 → 82		8.8	8.8	8.8	8.8	8.8	8.8	8.8	8.8	8.8	8.8	8.8	8.8	8.8	8.8	8.8	8.8	8.8	8.8	8.8	8.8	USt P+

$W = W - 0.13 \text{ USt max.}$

Jib weight & counter-jib ballast

▲▲▲▲	▲▲▲▲ (lb) - 33 LVF (+/- 5%)			▲▲▲▲		▲▲▲▲ (lb)
	▲▲▲▲	▲▲▲▲	▲▲▲▲	7,937 lb	2,425 lb	
213 ft	23,896	23,433	24,083	4	4	41,447
197 ft	23,455	22,992	23,642	4	4	41,447
180 ft	22,750	22,353	22,948	4	4	41,447
164 ft	22,088	21,691	22,287	4	4	41,447
148 ft	21,314	20,918	21,513	4	3	39,022
131 ft	20,455	20,058	20,653	4	2	36,597
115 ft	19,396	18,999	19,595	4	1	34,172
98 ft	18,290	17,893	18,488	4	0	31,747
82 ft	17,183	16,786	17,381	3	2	28,660

CAU - 7,937 lb

CAV - 2,425 lb

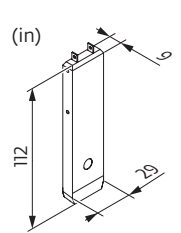
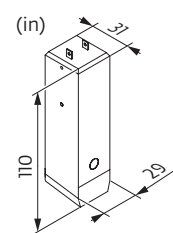







Dimensions and weight

Slewing crane part:  213 ft -  -  33 LVF

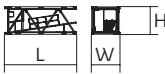

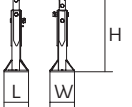
Slewing crane part		L (ft)	W (ft)	H (ft)	lb (+/- 5%)	
Counter-jib		36.7	5	8.3	13,096	
Towerhead + cab		Ultra View □ 5.2 ft □ 6.6 ft	15.4 15.6	7.5 7.5	8.2 8.2	14,749 16,513
Jib section		① 33 LVF 6 DVF	35.8	9.6	8.6	9,304
Jib section		②	33.7	3.4	7.9	4,156
Jib section		③ ④ ⑤ ⑦ ⑧ ⑩	17.2 17 17 17 17 16.9	3.4 3.4 3.4 3.4 3.4 3.4	7.7 7.6 7.6 6.3 6.2 3.9	1,654 1,327 1,327 860 774 529
Jib section		⑥ ⑨	17 16.9	3.4 3.4	7.6 6.2	1,058 661
Jib section		⑪	16.7	3.4	3.8	441
Hoisting winch (+ rope)		33 LVF 50 LVF 50 LVF GH	4.5 5 5.3	2.7 3.1 4.4	2.5 3 4.1	2,006 2,646 4,288
Trolley		 8.8 USt	5.9	4.4	3.2	362
Pulley block		 8.8 USt	3.3	1.4	6.6	441
Trolley		 8.8 USt	5.4	4.3	3	362
Trolley		 8.8 USt 4.4 USt	5.2 5.2	4.3 4.2	3 3	353 507
Pulley block		 8.8 USt 4.4 USt	5.4 3.6	0.8 0.5	5.6 4.9	675 695

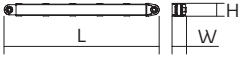
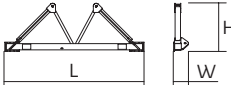
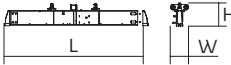
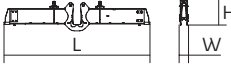
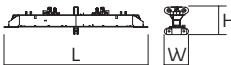
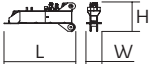
Crane tower			L (ft)	W (ft)	H (ft)	lb (+/- 5%)
Telescopic cage T41 Telescopic cage T61		□ 5.2 ft □ 6.6 ft	35.6 35.5	12.3 13.6	13.5 14.7	15,653 21,385
K40/K40 K60/K60		□ 5.2 ft □ 6.6 ft	7.3 7.3	6.9 8.1	6.8 8.2	3,208 4,365
K 447B K 447E KM 447E KM 449E K 649B KM 649E		□ 5.2 ft □ 5.2 ft □ 5.2 ft □ 5.2 ft □ 6.6 ft □ 6.6 ft	33.5 33.5 33.5 33.5 33.6 33.8	5.5 5.3 5.3 5.3 6.8 6.7	5.3 5.3 5.3 5.3 6.7 6.7	7,606 7,474 7,088 8,448 11,663 10,692
K 447A KMT 447A K 449A KMT 449A KR 649A KRMT 649A K 649A KMT 649A		□ 5.2 ft □ 5.2 ft □ 5.2 ft □ 5.2 ft □ 6.6 ft □ 6.6 ft □ 6.6 ft □ 6.6 ft	17.1 17.1 17.1 17.1 17.2 17.2 17.2 17.2	5.5 5.5 5.5 5.5 6.9 6.9 6.8 6.8	5.3 5.3 5.3 5.3 6.8 6.8 6.7 6.7	4,079 3,847 4,916 4,696 7,165 6,724 6,184 5,666
K 447C K 649C KRMT 649C		□ 5.2 ft □ 6.6 ft □ 6.6 ft	11.3 11.7 11.7	5.5 6.8 6.9	5.3 6.7 6.8	2,998 4,376 5,401
Fixing angles		P 41A P 602B	1.2 2.1	1.2 2.1	3.7 4.2	293 650
Basic mast unit		S 41A V 60A V 63A	11.9 16.4 32.9	6.4 7.9 7.9	6.8 7.9 7.9	6,537 9,674 16,502
Struts		S 41A V 60A V 63A	10.4 14.8 14.8	0.9 1 1.1	0.8 1 1.1	489 919 1,135
Half-bearer		S 41A V 60A V 63A	16.7 22 22	2 2.3 2.3	5.8 7.6 7.6	2,524 3,519 4,079
Cross girder		ZC 4230 ZD 4230	18.5 21.8	2.7 2.7	3.4 3.4	3,505 4,035
Cross girder		ZC 4230 ZD 4230	18.5 21.8	1.5 1.5	4.4 4.4	4,178 4,707
Cross girder		ZD 463	25.1	3.8	4.5	7,904
1/2 Cross girder		ZD 463	11.2	2.3	4.4	3,649

Mechanisms

480 V - 60 Hz											hp	kW	
	33 LVF 20 Optima	fpm	89	118	167	240	46	59	89	121	33	22	951 ft
		USt	4.4	3.3	2.2	0.9	8.8	6.6	4.4	2			
	50 LVF 20 Optima	fpm	157	203	285	397	82	108	151	200	50	37	1,191 ft
		USt	4.4	3.3	2.2	1.2	8.8	6.6	4.4	2.8			
50 LVF 20 GH Optima	fpm	161	210	289	371	82	105	151	187	50	37	2,080 ft	
	USt	4.4	3.3	2.2	1.2	8.8	6.6	4.4	2.9				
	6 DVF 4 Optima	fpm	0 → 262 (8.8 USt) 0 → 328 (2.2 USt)						5.5	4			
	RVF 162 Optima+	rpm	0 → 0.8						2 x 7.5	2 x 5.5			

480 V (+6% -10%) 60 Hz	33 LVF: 45 → 32 kVA 50 LVF / 50 LVF GH: 58 → 38 kVA	

33 LVF 20 Optima

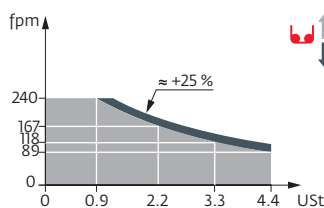

50 LVF 20 Optima

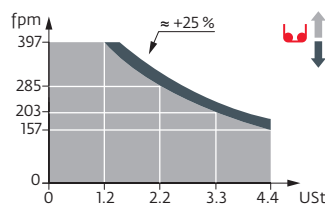

50 LVF 20 GH Optima

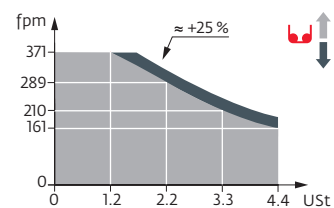

These mast combinations meet the EN 14439 and ASME B30.3-2016 specifications for "out of service" wind conditions, provided the illustrated wind speed matches required design wind speed for the location of the tower crane. The "out of service" design wind speed was determined in accordance with ASCE 7-10, Figure 26.5-1A. The wind velocity, used for this configuration was 98 mph (158 kph), which represents a nominal design 3-second wind gust at 33 ft (10 m) above ground for Exposure B category. A factor of 0.85 was applied to the 700-year ultimate design wind speed of 115 mph (185 kph), per ASCE 37-02, with the assumption that this crane is considered a temporary structure used during a construction period of 2 years or less.

- Jib elevation
- Total ballast weight
- Travelling
- Standard equipment
- Jib weight
- Required power
- Options
- Lorry 44 ft
- Power Control Function: winch speeds adapted to the available power
- Potain Plus function: Plus load curves
- Container High Cube 40 ft, and/or Flat Rack 20 ft
- Consult us
- Hook heights with Plus load curves
- Hoisting
- Reactions in service
- Trolleying
- Reactions out of service
- Slewing

This commercial document is not legally binding. For any technical information, please refer to the corresponding instructions.

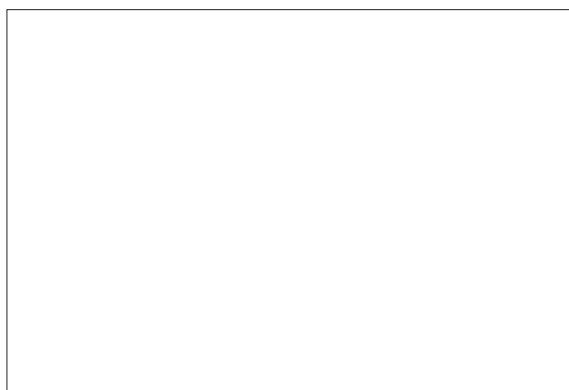

© 2019 The Manitowoc Company, Inc.
www.manitowoc.com