



PREMIUM PRO-E
0.25



Chain hoist PLANETA-PREMIUM PRO-E

Available for load capacities up to 1,000 kg. The new **PLANETA-PREMIUM PRO-E** series is a further development of our reliable manual chain hoist **PREMIUM PRO**. Instead of a hand chain this manual chain hoist is driven by a cordless screwdriver. Corrosion protection and material are at the same high level. The work can now be done with less effort.

Product features:

- Galvanized load chain acc. EN 818-7-T
- Completely protected against corrosion
- Closed housing against dust and dirt
- 360° freely rotating support and load hooks, made of hardened and tempered steel
- Driven by cordless screwdriver

Only operate in battery/rechargeable battery mode!

No operation by pneumatic or hydraulic or mains operated support

Optional: With RFID chip for digital equipment testing.

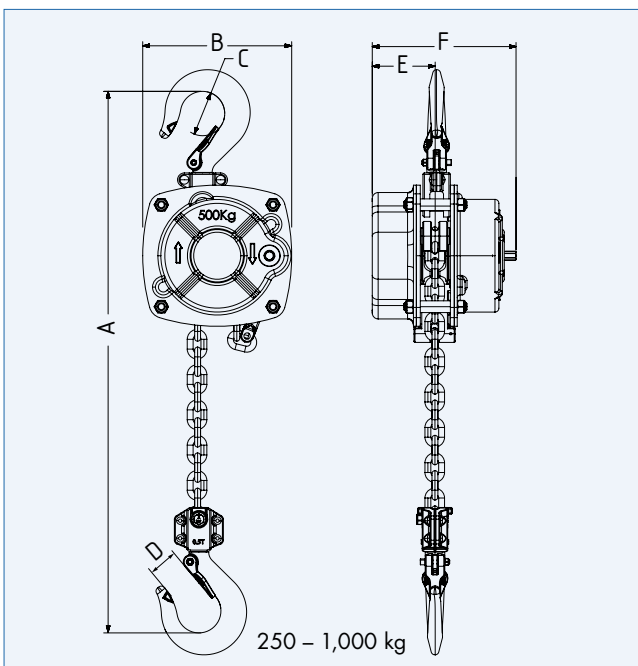

TYPE	PREMIUM PRO-E ...	0.25	0.5	1
Capacity*	kg	250	500	1,000
Chain size	mm	5 x 15	6 x 18	8 x 24
Number of chain falls		1	1	1
Min. headroom (A)	mm	318	390	417
Maximum drive speed	r/min	2,500	2,500	2,500
Lifting speed at max. drive speed	m/min	2.35	2.12	1.46
B (Dimensions)	mm	122	152	176
C	mm	35	45	50
D	mm	25	30	34
E	mm	54	64	76
F	mm	123	147	164
Net weight	kg	7.6	10.5	16.2
Weight for 1 m additional lifting height	kg	0.5	0.8	1.4
PREMIUM PRO-E ... with 3 m lift	Order No.	G10470	G10471	G10472
Additional 1 m lift	Order No.	G10473	G10474	G10475
RFID chip incl. mounting	Order No.	G10600	G10600	G10600

* Load capacities 2,000 kg, 3,000 kg on request!