

# Concitherm Plate Heat Exchangers

## The large evaporator plate

Concitherm stands for an efficient and true free flow plate heat exchanger with the highest performance. Optimised plate design enables wide flow gaps with few contact points even with 3 m<sup>2</sup> per laser-welded cassettes. Low pressure losses in the heat exchanger avoid an intermediate pump, hence reduce installation and operational costs. Furthermore, in comparison to conventional tube evaporators, Concitherm offers an almost 100% higher heat transfer coefficient. Concitherm plate evaporators can serve as boosters to conventional evaporators as well as in stand-alone applications.

### Your advantages at a glance

3 m<sup>2</sup> heat transfer surface per laser-welded cassette enables:

- large evaporator duties
- compact unit design
- short resistance time
- less gaskets

Large inlet/outlet areas for vapours result in:

- high evaporation capacity
- lower investment costs, if used as a booster to a Robert's evaporator

Free flow gaps ensure:

- constant juice flow into the vapour chamber
- low pressure drops
- high heat transfer coefficient (OHTC-value)



## Concitherm 193

The Concitherm CT 193 is the ideal evaporator system for liquid media containing particles. Compared with traditional tube evaporators the Concitherm offers high heat transfer values and an extremely short residence time of the media which has a particularly beneficial effect on the quality of sensitive products.

The Concitherm CT 193 is a semi-welded plate rising film evaporator with embossed special steel plates and a carbon steel frame. Two pressed plates are welded at the edges to form a gastight cassette. This creates welded plate gaps for the heating steam and gasketed gaps for the product to be evaporated. The free flow of the medium is ensured by a 7.5 mm plate gap. The plate structure is specially designed for evaporation applications. The system's performance can be

adapted or changed at any time simply by increasing or decreasing the number of cassettes. And the Concitherm CT 193 is extremely lightweight, easy to install and compact to save space within the evaporator plant.

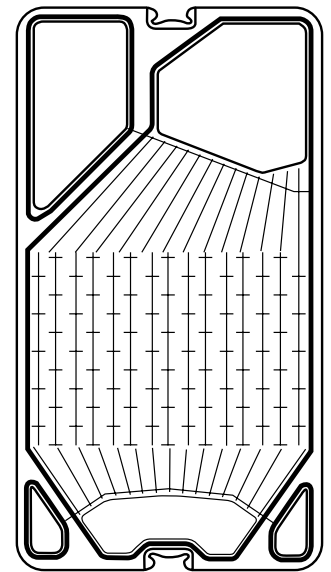
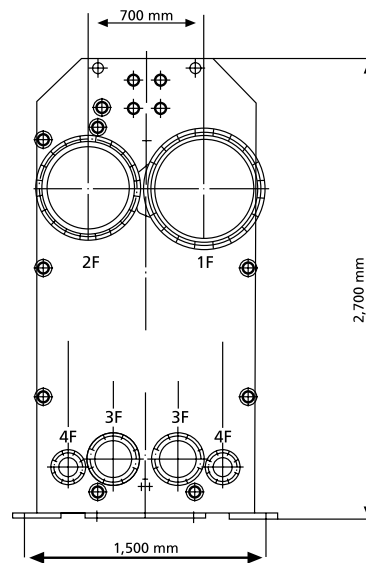
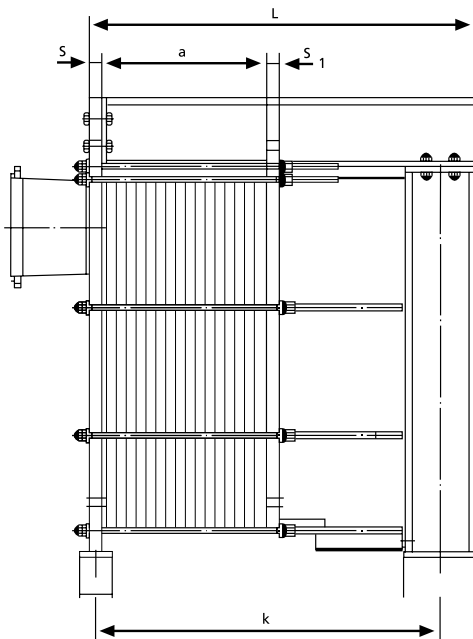

Connections: 1F – DN 600 mm    2F – DN 500 mm    3F – max. DN 150 mm    4F – max. DN 100 mm

## GEA PHE Systems – Competence in Heat Transfer

With emphasis on the highest quality standards and constant innovations, GEA PHE Systems continues to expand its market position: Within the GEA Process Equipment Division, GEA Ecoflex together with GEA ViEX, GEA WTT, GEA Ecobraze, GEA PHE Systems NA and GEA EcoServe forms GEA PHE Systems, the Center of Competence and Service Center for gasketed, fully welded and brazed plate heat exchangers of GEA Group:

- HVAC
- Refrigeration
- Sugar
- Chemical
- Paper
- Food
- Power
- Marine
- General Industry
- Renewable Energy

The specifications contained in this printing unit are intended only to serve the non-binding description of our products and services and are not subject to guarantee. Binding specifications, especially pertaining to performance data and suitability for specific operating purposes, are dependent upon the individual circumstances at the operation location and can, therefore, only be made in terms of precise requests.

Your contact:



### GEA Ecoflex GmbH

Karl-Schiller-Straße 1-3 · 31157 Sarstedt · Germany  
 Phone +49 5066 601-0 · Fax +49 5066 601-104  
 info@gea-ecoflex.com · www.gea-phe.com