

# K-Beam® Accelerometer

Type 8315A...

## Capacitive MEMS, Single Axis Accelerometer

Type 8315A ... is a high sensitivity, low noise, single axis accelerometer family which measures acceleration and/or low-frequency vibration in the primary sensing axis. The accelerometer features include:

- Measuring ranges:  $\pm 2$  g,  $\pm 10$  g,  $\pm 30$  g,  $\pm 50$  g,  $\pm 100$  g,  $\pm 200$  g
- Frequency response: 0 ... 1 000 Hz (5 %) (except  $\pm 2$  g)
- Bipolar  $\pm 4$  V, single ended  $2,5$  V  $\pm 2$  V and  $\pm 8$  V differential accelerometer output options
- Operating temperature  $-55$  ...  $125$  °C
- Low noise
- Excellent thermal stability
- 25,4 x 21,6 mm footprint
- Wide supply voltage range, 6 ... 50 VDC
- 6 000 gpk shock rated
- Conforming to CE

### Description

The 8315A... Capacitive Accelerometer family utilizes a silicon Micro-Electro-Mechanical System (MEMS) variable capacitance sensing element. The sensing element of each axis, consists of a very small inertial mass and a flexure element cantilever positioned between two plates. As the mass deflects under acceleration, the capacitance between these plates changes. AC excitation and synchronous amplitude demodulation circuitry contained in the accelerometer's internal signal conditioner provides an analog output signal proportional to the applied acceleration. This output signal is scaled as a voltage which is proportional to the applied acceleration.

There are 3 housing/electrical interface options (AC, TA, TB) which determine the available output signal formats. The accelerometer is powered by a single regulated supply between 6 and 50 VDC.

The AC option is a hard anodized aluminum housing with an epoxy seal and an integral PVC cable. The maximum temperature range is  $+85$  °C and the available output signal formats are bipolar  $0\pm 4$  V, single ended  $2,5\pm 2$  V and differential  $0\pm 8$  V. The sensing element and electronics are contained in this lightweight housing with an environmental seal and integral ground isolation.



8315A ... TA

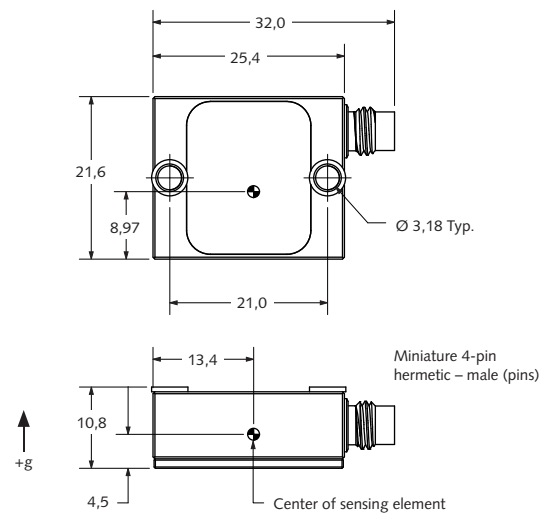

The TA and TB options offer a welded titanium housing with either an industry standard 4-pin,  $\frac{1}{4}$ -28 connector or integral Teflon® jacketed cable. The maximum temperature range is  $+125$  °C and the available output signal formats are bipolar  $0\pm 4$  V (with temperature output) , single ended  $2,5\pm 2$  V (with temperature output) and differential  $0\pm 8$  V. Temperature output is provided if external compensation of the output signal is desired. The sensing element and electronics are contained in a lightweight, welded titanium housing for a fully hermetic design with integral ground isolation. For adhesive mounting, the hard anodized plate, at the bottom of the sensor provides ground isolation. For screw mounting, the sensors are supplied with integral isolation inserts in the screw holes to ensure a ground isolated mount in combination with the hard anodized plate on the bottom of the sensor.

8315A\_000-859e-08.11

Teflon® is a registered trademark of DuPont

This information corresponds to the current state of knowledge. Kistler reserves the right to make technical changes. Liability for consequential damage resulting from the use of Kistler products is excluded.

### Application

The 8315A ... is an instrument grade, single axis accelerometer. As such, the 8315A ... is well suited for a wide variety of R&D and OEM applications requiring precision measurements and packaging designed for demanding application and handling needs.

In particular, the sensor design is optimized for low frequency applications common to Aviation/Aerospace, Automotive, Civil Engineering Structures, Seismic and other R&D studies. In particular, Aviation/Aerospace ground and flight testing often evaluates dynamics and structural vibration to assess performance parameters, reliability and integrity. Automotive laboratory and road testing often evaluates system parameters such as vehicle ride, dynamics and structural analysis to assess performance parameters, reliability and durability. Civil engineering structures such as bridges often are evaluated for structural response to assess the integrity of the bridge to ensure safety. Seismic ground and structural testing is often performed to measure the effect of earthquakes and other natural phenomena. Other R&D studies include human motion studies, robotics and platform motion control systems for example.

### Mounting

Reliable and accurate measurements require that the mounting surface be clean and flat. The accelerometer can be directly attached to the test structure with the supplied screws for a ground isolated mount or with adhesive. Several optional accessories are offered to mount the 8315A ... The 8464K01 is an adhesive mounting base with 2, 4-40 threaded holes to mount the sensor with the supplied screws. The 8464K02 is similar to the 8464K01 except is has a threaded 10-32 hole to provide a ground isolated stud mount. The 8464K03 is similar to the 8464K01 except it provides magnetic mounting for the sensor. The 8522 is a triaxial mounting cube which is used to provide a biaxial or triaxial solution for the 8315A family of sensors. The instruction manual for the 8315A ... provides detailed information regarding mounting surface preparation.

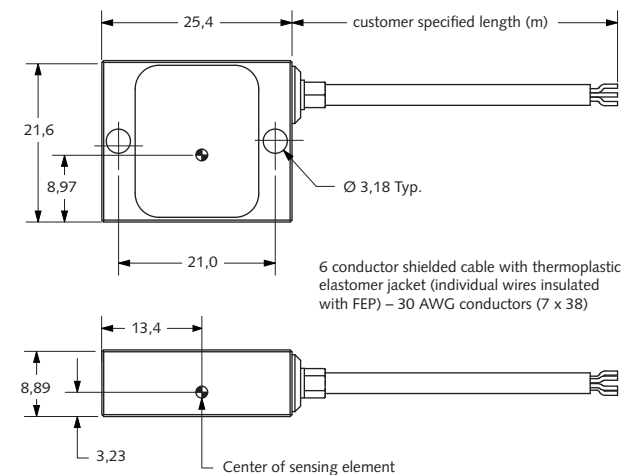
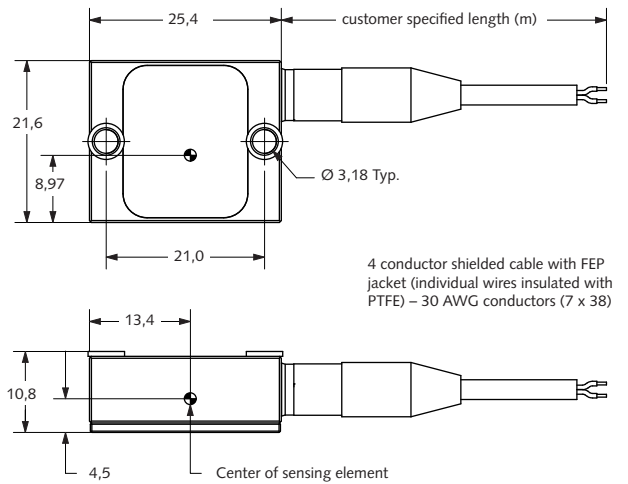

Type	Unit	8315A2D0	8315A010	8315A030	8315A050	8315A100	8315A200
Acceleration range	g	±2	±10	±30	±50	±100	±200
Frequency response, ±5 %	Hz	0...250	0...1000				
Damping ratio, typical		0,7	0,7	0,7	0,7	0,7	0,7
Sensitivity, ±5 % (ref 100 Hz) , Output Type (A; B; D)	mV/g	2 000; 1 000; 4 000	400; 200; 800	133,3; 66,6; 266,6	80; 40; 160	40; 20; 80	20; 10; 40
Resonant frequency, nom.	kHz	1,3	2	4	5,1	7,2	11
Transverse sensitivity, typ. (max.)	%	1,0 (3,0)					
Sensitive axis misalignment, typ. (max.)	mrad	10 (30)					
Amplitude linearity, max.	% FSO	±1					
Phase shift (max.) 0 (@ 0 Hz) ; 2 (@ 10 Hz) ;	degrees	20 (@ 100 Hz)	10 (@ 100 Hz)				
Noise density, 0 - 100 Hz typ. (max)	mgrms/√ Hz	0,025 (0,030)	0,125 (0,15)	0,375 (0,45)	0,625 (0,75)	1,25 (1,5)	2,5 (3)
Noise 0 - 100 Hz, typ.	mgrms	0,25	1,25	3,75	6,25	12,5	25
Resolution (threshold), typ.	mgrms	0,35	1,75	3,85	8,75	17,5	35
<b>Electrical</b>							
0 g output, Output Type (A ; B ; D)	mV	0 ±60 ; 2 500 ±60 ; 0 ±120					
Capacitive load, max.	µF	0,5					
Load resistance, min.	kΩ	30					
Output impedance, typ.	Ω	300					
Supply current, nom.	mA	1,6					
Supply voltage, temperature	VDC	6 ... 50 (≤ 100 °C); 6 ... 35 (≤ 110 °C); 6 ... 20 (≤ 120 °C); 6 ... 12,5 (≤ 125 °C)					
Reverse polarity protection		Yes					
<b>Environmental</b>							
Shock, (half sine, 200 µs)	g	6 000					
Random, (20 - 2 000 Hz)	g rms	20					
Storage temperature range	°C	-55 ... 125 (TA or TB housing); -55 ... 85 (AC housing)					
Operating temperature range	°C	-55 ... 125 (TA or TB housing); -55 ... 85 (AC housing)					
Temp. coeff. sensitivity, typ. (max)	ppm/°C	±100 (±300)					
Temp. coeff. sensitivity, typ. (max)	%/°C	±0,01 (±0,030)					
Temp. coeff. of bias, typ. (max)	mg/°C	±0,1 (±0,8)	±0,5 (±4)	±1,5 (±12)	±2,5 (±20)	±5 (±40)	±10 (±80)
<b>Temperature sensor</b>							
Output @ 20 °C	V	1,632					
Sensitivity	mV/°C	-11,77					
Accuracy	°C	±5					
<b>Physical</b>							
Case		Titanium or Anodized Aluminum					
Mounting		4-40 / M3					
Sealing		Environmental (AC housing); Hermetic (TA or TB housing)					
Ground isolation		Yes					
Weight (excluding cable)	grams	15 (TA or TB housing)/ 12 (AC housing)					
Cable length tolerance	m	±0,1					

Operation of sensor with supply voltage exceeding stated values at indicated temperatures will cause permanent damage to sensor.

**Optional Accessories**

- Adhesive mounting base (off-ground) with two 4-40 female threaded holes on sensor side **8464K01**
- Mounting base (off-ground) with two 4-40 female threaded holes on sensor side, one 10-32 threaded female thruhole, with 10-32 stud **8464K02**
- Magnetic mounting base **8464K03**
- Triaxial mounting cube, with 10-32 UNF-2A x 1/2" screw and #10 washer, two 4-40 UNC-2A x 7/16" screws with washers **8522**
- Baseplate conversion for backward compatibility to 8305/8310/8312 mounting pattern with 10-32 stud **8464K04**
- Flexible shielded breakout cable, silicone jacket (mates with 8315 with integral connector option) pigtail wires on opposite end (lengths 2, 5, 10 and sp meters) **1534AxxK00**
- Extension cable, 4-pin 1/4-28 neg. to 4-pin 1/4-28 neg. Teflon® jacket **1592A ...**
- Output cable, 4-pin neg., 1/4-28 neg. to pigtails Teflon® jacket **1592M1sp**

**Included Accessories Titanium Housing**

- Mounting screw, M3 x 14mm long **431-0492-004**
- Mounting screw, 4-40 UNC-2A x 9/16" long **431-0491-002**
- Mounting wax **8432**

**Included Accessories Aluminum Housing**

- Mounting screw, M3 x 12 mm long **431-0492-003**
- Mounting screw, 4-40 UNC-2A x 1/2" long **431-0375-005**
- Fiber washer **434-0318-001**
- Mounting wax **8432**

Electrical Interface			Function-Output		
A (pin)	B (Wire Color)	C (Wire Color)	Type A0, B0	Type AT, BT	Type D0
1	Red	Red	Power	Power	Power
2	Black	Black	Return	Return	Return
3	Yellow	Green	N/C	Temperature	Output-
4	White	White	Output+	Output+	Output+
-	-	Orange	N/C	N/C	N/C
-	-	Blue	N/C	N/C	N/C
-	Shield	Shield	Case	Case	Case

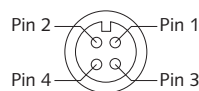

1/4-28, 4-pin connector sensor view

**Ordering Key**

Type 8315A

**Measuring Range**

±2 g	<b>2D0</b>
±10 g	<b>010</b>
±30 g	<b>030</b>
±50 g	<b>050</b>
±100 g	<b>100</b>
±200 g	<b>200</b>

**Output Type**

0±4 V FSO, no temperature output	<b>A0</b>
0±4 V FSO, with temperature output	<b>AT</b>
2,5±2 V FSO, no temperature output	<b>B0</b>
2,5±2 V FSO with temperature output	<b>BT</b>
0±8 V FSO differential, no temperature output	<b>D0</b>

**Housing/Electrical Interface**

Anodized aluminum housing with integral cable (max temperature to 85 °C (output types A0, B0 and D0 only)	<b>AC</b>
Titanium housing with 4 pin connector (output types AT, BT and D0 only)	<b>TA</b>
Titanium housing with integral cable (teflon) (output types AT, BT and D0 only)	<b>TB</b>

**Cable Length**

none	<b>00</b>
sp = length in meters (for AC and TB housing/electrical interface only)	<b>sp</b>

Measure	Connect	Amplify	Output	Analyze
Type 8315A ... AC Type 8315A ... TB Integral cable	Integral pigtail	customer supplied		Read out
Type 8315A ... TA 4-pin pos.	Type 1592M1/1534A ... 4-pin neg. pigtails	customer supplied		Read out
Type 8315A ... TA 4-pin pos.*	Type 1592A ... 4-pin neg. 4-pin neg.	Type 5210 Power supply	Type 1511 BNC pos. BNC pos.	Read out

Fig. 1: Measuring chain

\* excludes D0 (Differential) output Types

8315A\_000-859e-08.11