

# Prüfpumpen

Languages > 

## Prüfpumpen PI 25 - 50 - 100



Prüfpumpe PI 25-50-100  
Art.-Nr.:257110102510 - 257110000000

### Merkmale

Prüfpumpe zur Druckprüfung von Rohrleitungen und Behälter  
Pumpenkörper aus Gauguß  
Stahlbehälter, Kolben und Ventile aus Messing  
Manometer

### Technische Daten

#### Prüfpumpe PI 25

Anschlußgewinde Ø 3/8" außen  
Behälter Volumen 12 Liter  
Max. Druck 25 bar  
Gewicht 10 kg

#### Prüfpumpe PI 50

Anschlußgewinde Ø 3/8" außen  
Behälter Volumen 38 Liter  
Max. Druck 50 Bar  
Gewicht 21,5 kg

#### Prüfpumpe PI 100

Anschlußgewinde Ø 3/8" außen  
Behälter Volumen 38 Liter  
Max. Druck 100 Bar  
Gewicht 21,5 kg

### Pumpenmaße

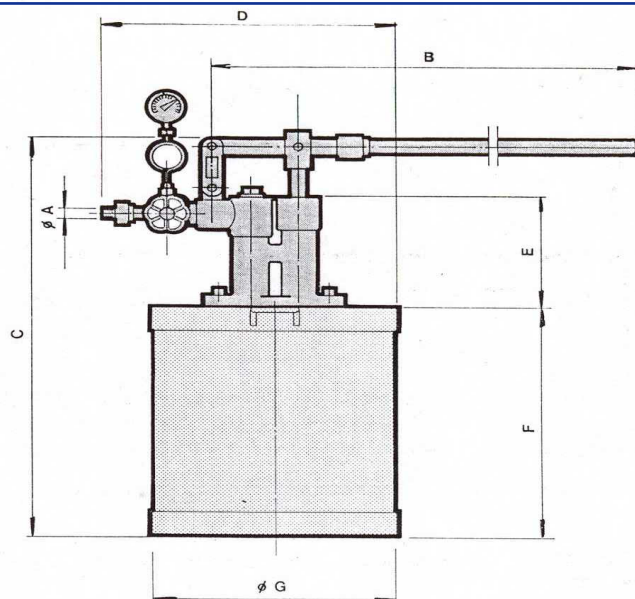

Typ	A	B	C	D	E	F	G	Kg
PI / 25	1/2" GAS	420	450	315	120	272	255	10,300
PI / 50	1/2" GAS	683	558	404	150	397	390	21,600
PI / 100	1/2" GAS	683	558	404	150	397	390	21,600

\* Änderungen und Irrtümer vorbehalten, alle Preise zzgl. Verpackung und Mwst.

# Prüfpumpen

Languages > 

## Prüfpumpen PI 25 - 50 - 100



Prüfpumpen PI 25-50-100  
Art.-Nr.: 257110102510 - 257110000000

### Ersatzteilliste

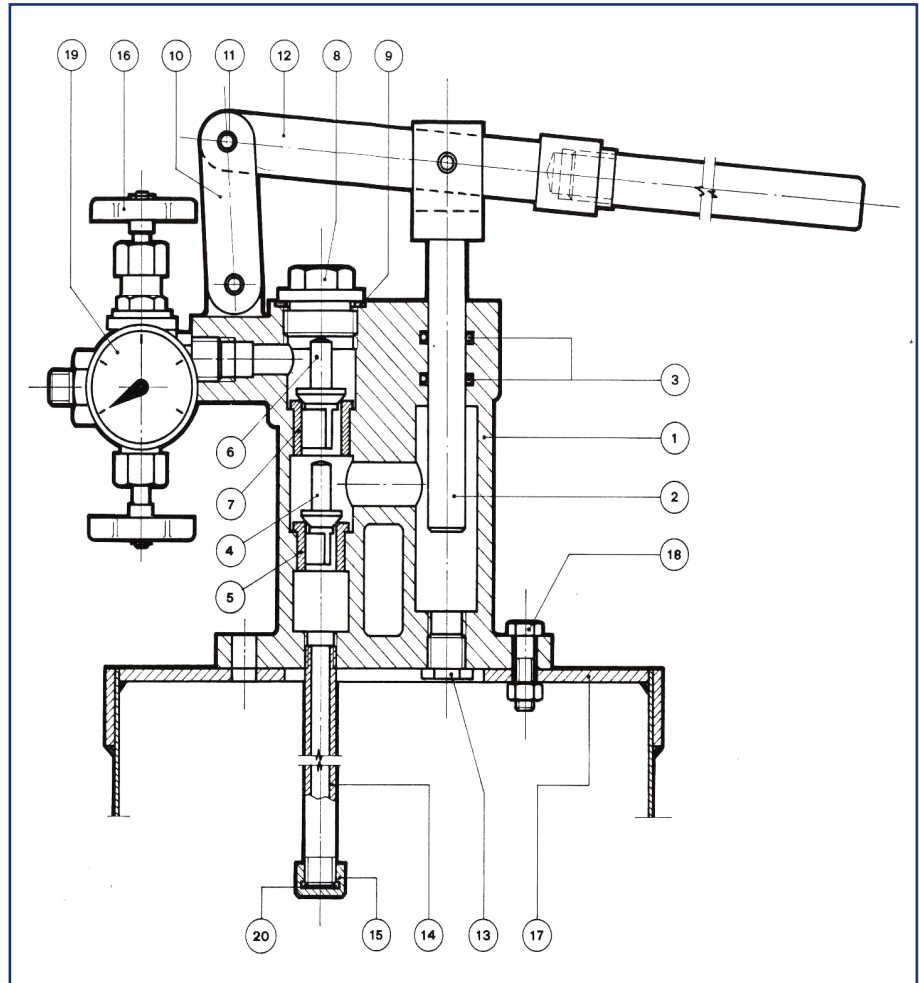

### Beschreibung der Ersatzteile

1. Körper	10. Pumpenhebel
2. Kolben	11. Elastischer Anschlussstift
3. Dichtungsring	12. Hebel
4. Unterer Schließer	13. Unterer Stopfen
5. Sitz des unteren Schließers	14. Ansaugrohr
6. Oberer Schließer	15. Filterkappe
7. Sitz des oberen Schließers	16. Hahn
8. Stopfen	17. Behälter
9. Dichtung	18. Bolzen
10. Pumpenhebel	19. Edelstahlfilter

\* Änderungen und Irrtümer vorbehalten, alle Preise zzgl. Verpackung und Mwst.

# Test Pumps

Languages > 

## Test Pumps PI 25 - 50 - 100



Test Pumps PI 25-50-100  
Art.-Nr.:257110102510 - 257110000000

### Characteristics

Manual hydraulic test pump for leakage testing of tubes and containers in sanitarian and heating techniques  
Cast iron body and cover  
Steel container, coil and double control valve  
Pressure gauge

### Technische Daten

#### Test Pump PI 25

Male Thread  $\varnothing$  3/8"  
Tank Volume 12 liter  
Max. Pressure 25 bar  
Weight 10 kg

#### Test Pump PI 50

Male Thread  $\varnothing$  3/8"  
Tank Volumen 38 liter  
Max. Pressure 50 Bar  
Weight 21,5 kg

#### Test Pump PI 100

Male Thread  $\varnothing$  3/8"  
Tank Volumen 38 Liter  
Max. Pressure 100 Bar  
Weight 21,5 kg

### Measurements

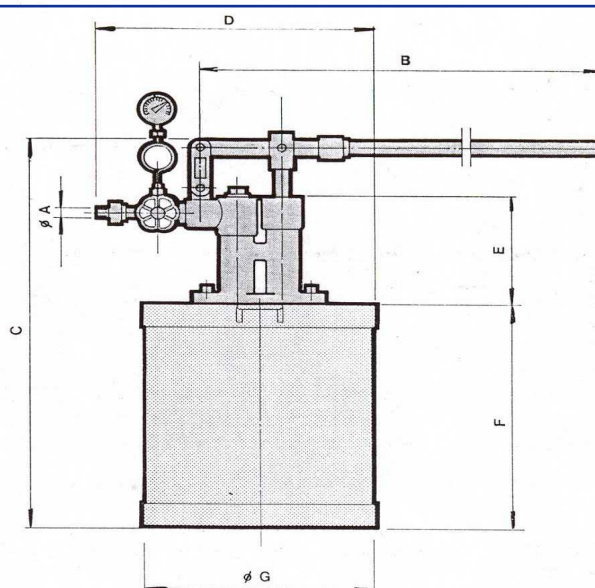

Type	A	B	C	D	E	F	G	Kg
PI / 25	1/2"GAS	420	450	315	120	272	255	10,300
PI / 50	1/2"GAS	683	558	404	150	397	390	21,600
PI/100	1/2"GAS	683	558	404	150	397	390	21,600

\* Changes and mistakes excepted, prices plus packing and VAT.

# Test Pumps

Languages > 

## Test Pumps PI 25 - 50 - 100



Test Pumps PI 25-50-100  
Art.-Nr.:257110102510 - 257110000000

### Spare Part list

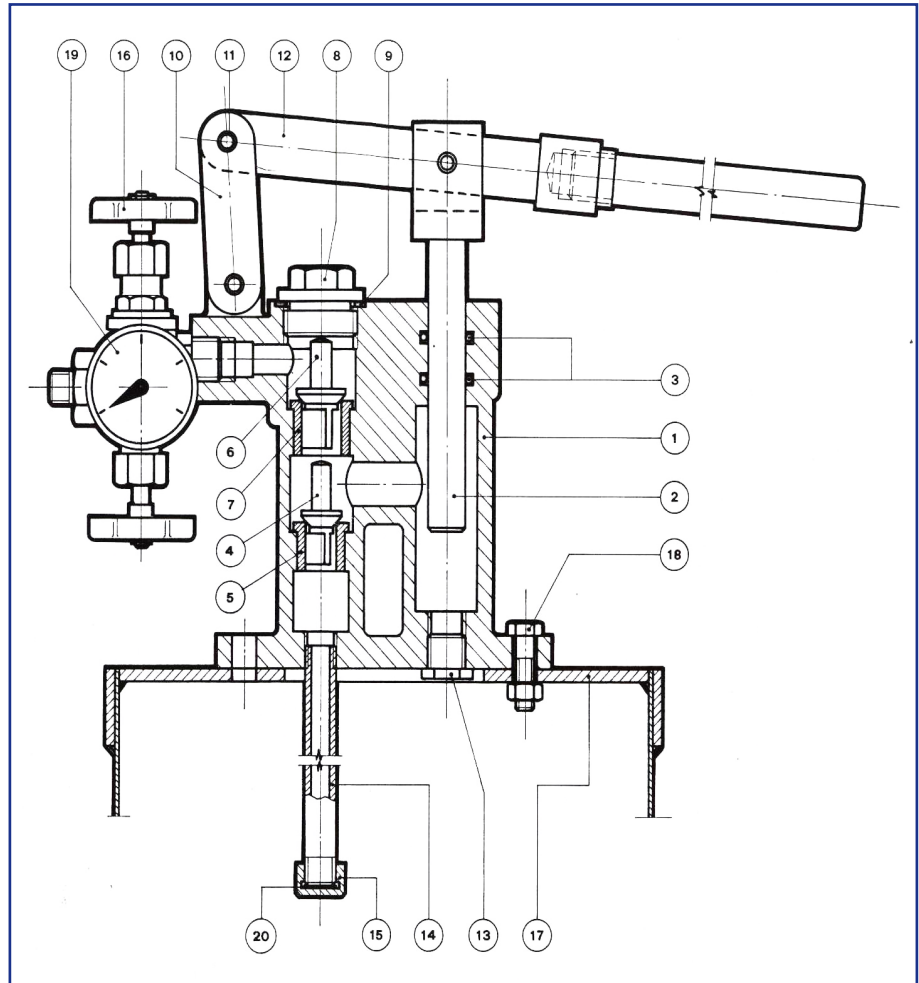

### Spare Part list description

1. Body	10. Pump lever
2. Piston	11. Elastic pin
3. O-Ring	12. Lever
4. Inferior shutter	13. Inferior plug
5. Inferior shutter seat	14. Suction tube
6. Superior shutter	15. Filter Cap
7. Superior shutter seat	16. Tap
8. Plug	17. Tank
9. Seals	18. Bolt
10. Pump lever	19. Stainless Steel filter

\* Changes and mistakes excepted, prices plus packing and VAT.