

FLAT TOP TOWER CRANE



Specifications:

- ▶ Max jib length: 80,00 m
- ▶ Capacity at max length: 4,00 t
- ▶ Max capacity: 20,00 t

WORKS FOR YOU.™

KEY

Legenda · Zeichenerklärung · Légende · Leyenda · Legenda · Условные обозначения



Hoisting · Sollevamento · Heben · Levage · Elevación · Elevação · Подъем



Trolleying · Traslazione carrello · Katzfahren · Distribution · Distribución · Distribuição · Передвижение каретки



Slewing · Rotazione · Schwenken · Orientation · Orientació · Giro · Поворот



Travelling · Traslazione · Schienenfahren · Translation · Traslación · Móvel · Передвижение



Directive on noise level · Direttiva sul livello acustico · Richtlinie für den Schall-Leistungspegel · Directive sur le niveau acoustique · Directiva sobre el nivel acustico · Diretiva sobre nível de ruídos · Директива по уровню шума



Consult us · Consultateci · Auf Anfrage · Nous consulter · Consultarnos · Consulte-nos · Проконсультироваться с нами



Power requirements · Potenza totale richiesta · Geforderte Stromstärke · Puissance totale nécessaire · Potencia necesaria · Requisitos de energia · Требования по питанию



Power supply · Alimentazione · Stromversorgung · Alimentation · Alimentación · Fonte de alimentação · Питание



In service · In servizio · In Betrieb · En service · En servicio · Em serviço · При работе



Out of service · Fuori servizio · Außer Betrieb · Hors service · Fuera de servicio · Fora de serviço · В режиме простоя



Max. under hook height · Altezza max. sotto gancio · Höchste Hakenhöhe · Hauteur maxi. sous crochet · Maxima altura bajo gancho · Alt. máx. sob o gancho · Макс высота крюка



Without load, without ballast, max. jib and max. height · A vuoto, senza zavorra, braccio max., altezza max. · Ohne Last und Ballast, mit Maximalausleger und Maximalhöhe · A vide, sans lest, avec flèche et hauteur maximum · Sin carga, sin lastre, con pluma y altura máxima · Sem carga, sem lastro, lança máxima, altura máxima · Без груза, без балласта, на макс. Длине вспомогательной стрелы и макс. Высоте



Counterweight · Zavorra controbraccio · Gegengewicht · Lest de contre-flèche · Lastre de contra flecha · Contrapeso · Противовес

C25

EN 14439-C25 · EN 14439 - C25 · EN14439 - C25 · EN 14439 - C25 · EN 14439 - C25 · EN 14439 - C25 · EN14439 - C25

CONTENTS

СТТ 472-20

Indice · Inhalt · Contenu · Contenido · Sumário · Содержание

Page · Pagina · Seite · Page · Página · Página · Страница:

Load Diagram · Diagramma di portata · Lastkurven · Courbes de charges · Curvas de cargas · Diagrama de carga · Диаграмма грузоподъёмности	4
Tower · Torre · Turm · Tour · Torre · Torre · Башня	8
Mechanisms · Meccanismi · Antriebe · Mécanismes · Mecanismos · Mecanismo · Механизм	16
Transportation · Trasporto · Transport · Transport · Transporte · Transporte · Транспортировка	18

LOAD DIAGRAM

Diagramma di portata · Lastkurven · Courbes de charges · Curvas de cargas · Diagrama de carga · Диаграмма грузоподъёмности

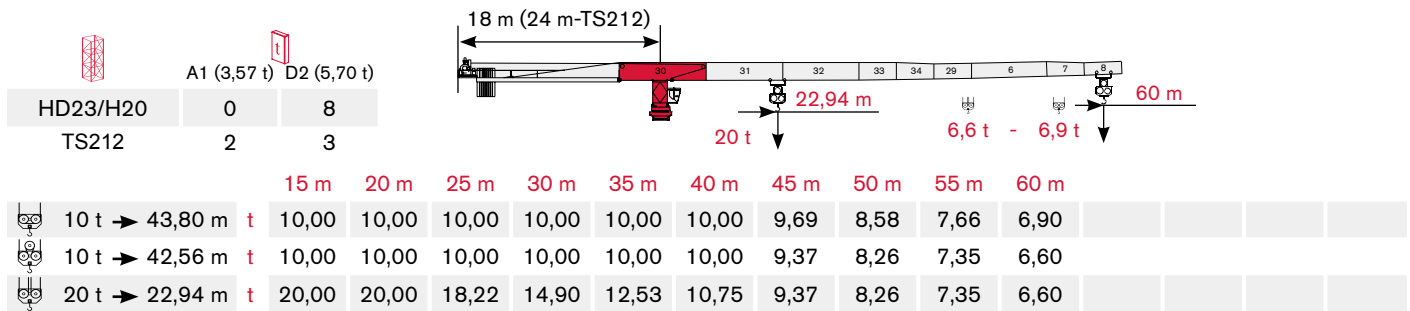
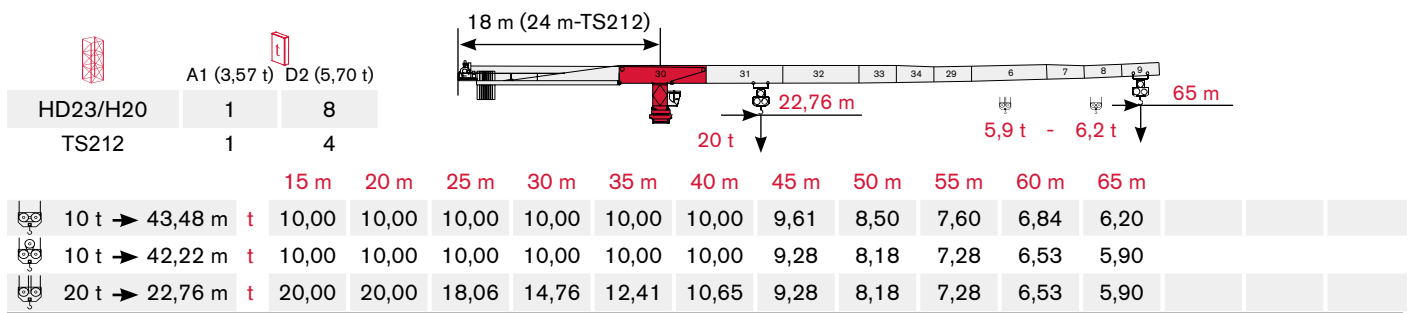
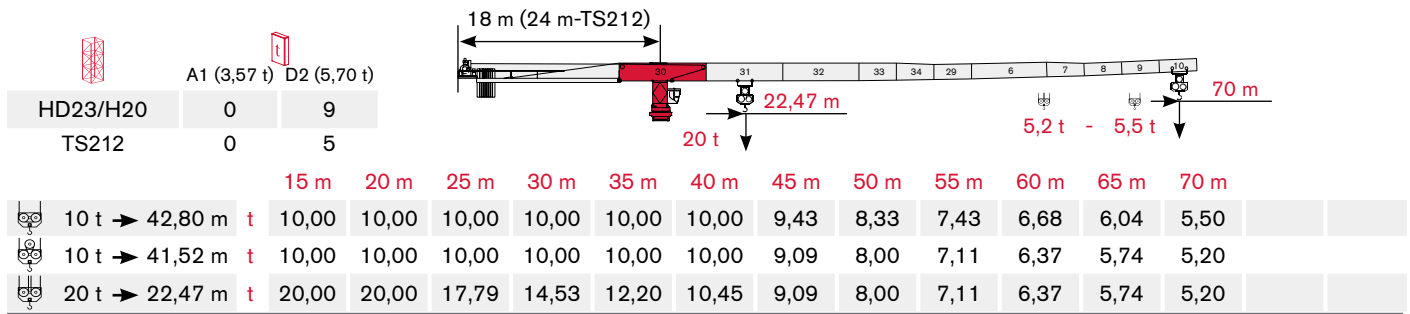
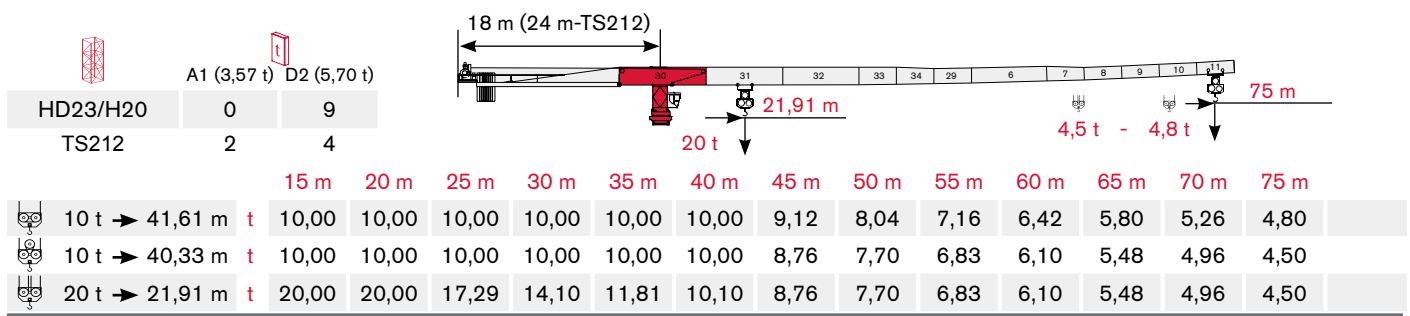
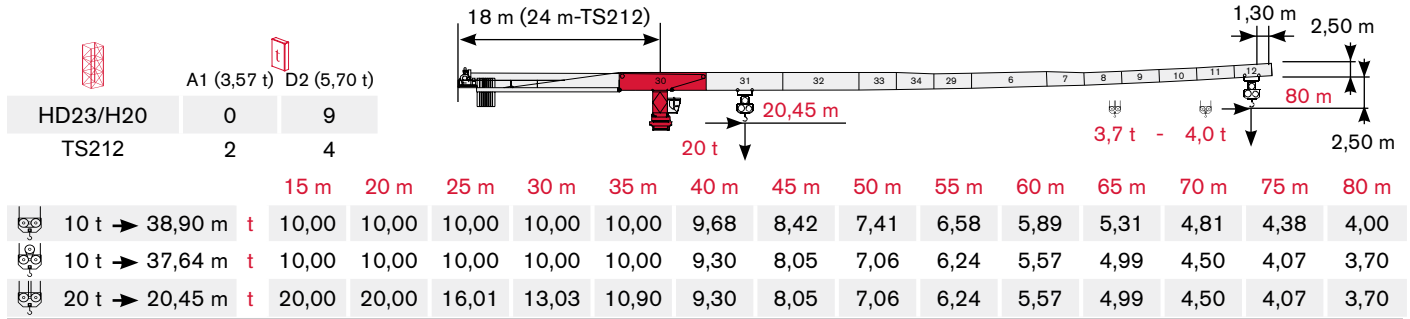

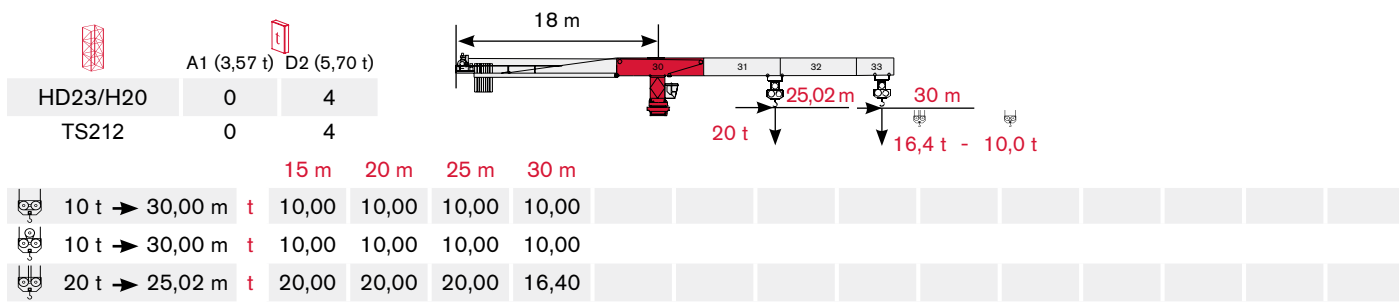
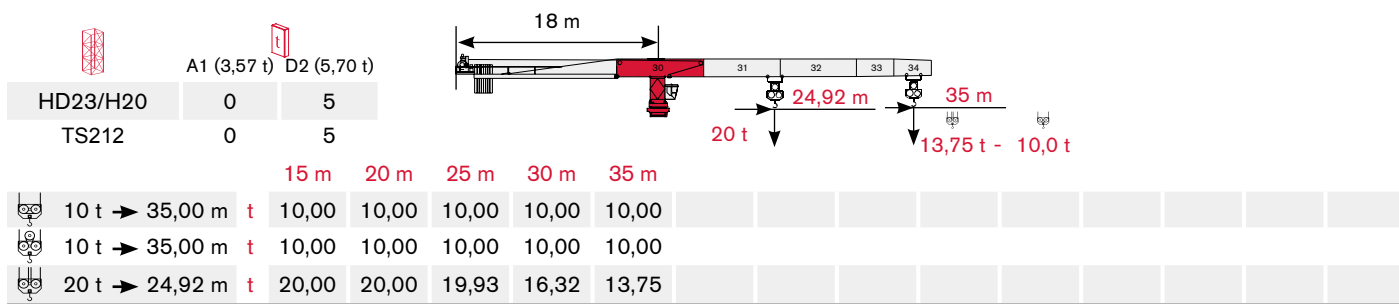
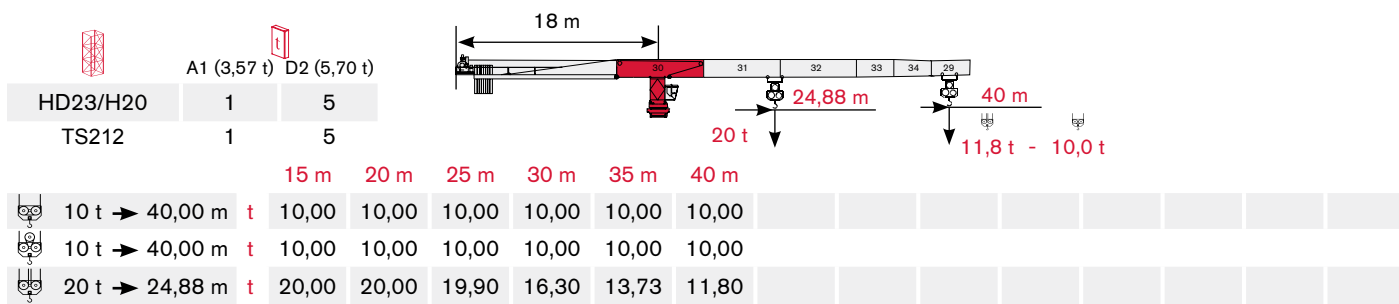
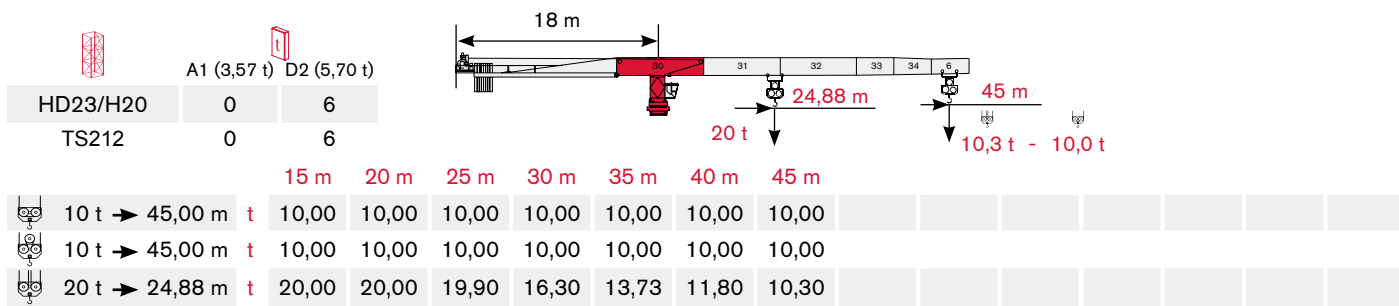
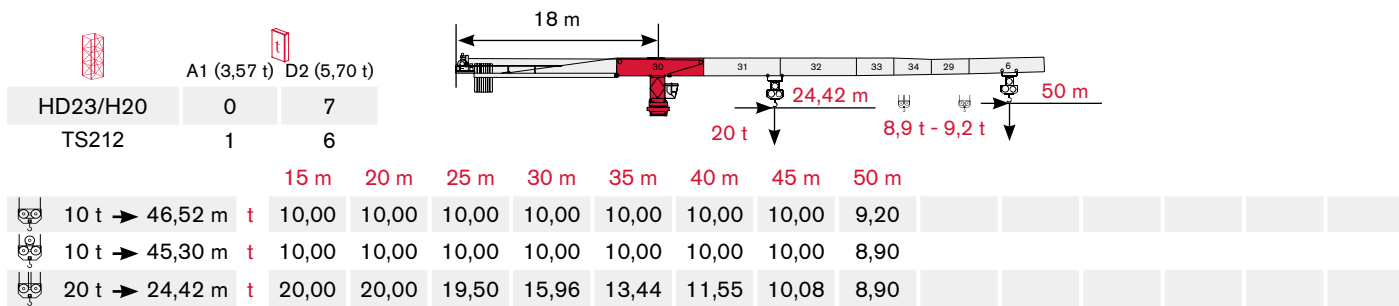
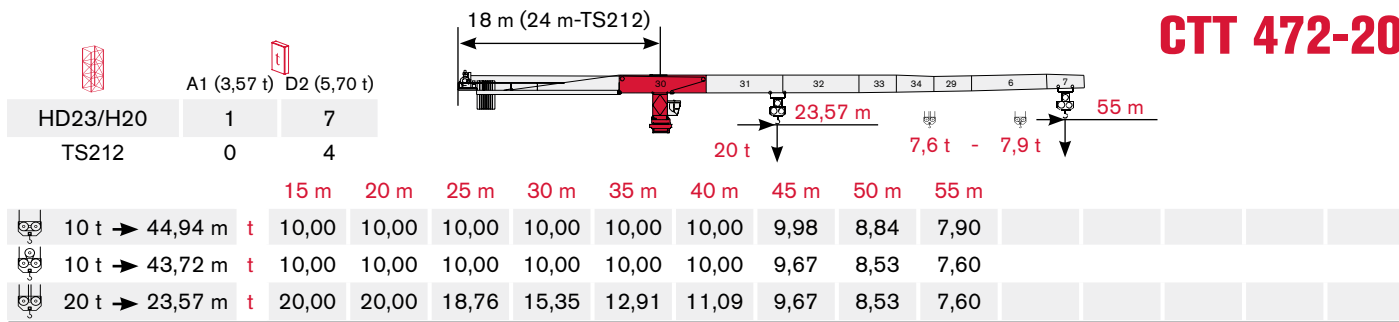

LOAD DIAGRAM

Diagramma di portata · Lastkurven · Courbes de charges · Curvas de cargas · Diagrama de carga · Диаграмма грузоподъёмност

TEREX POWER PLUS

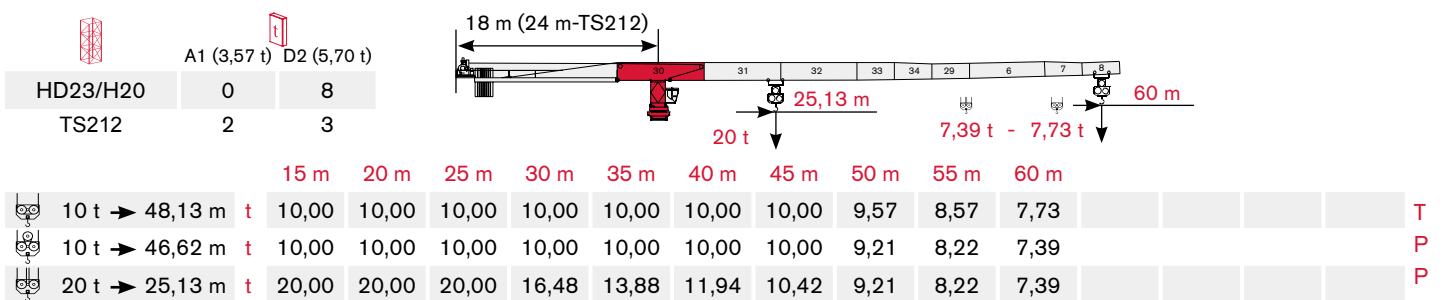
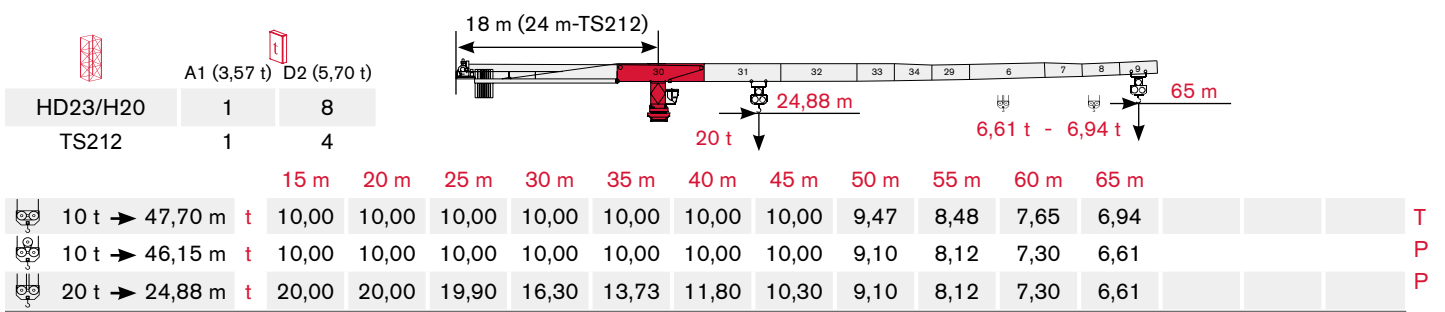
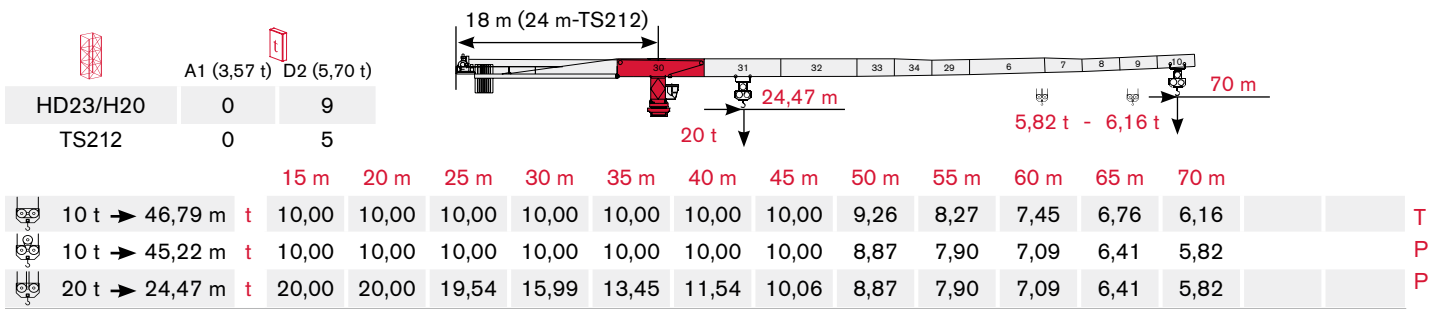
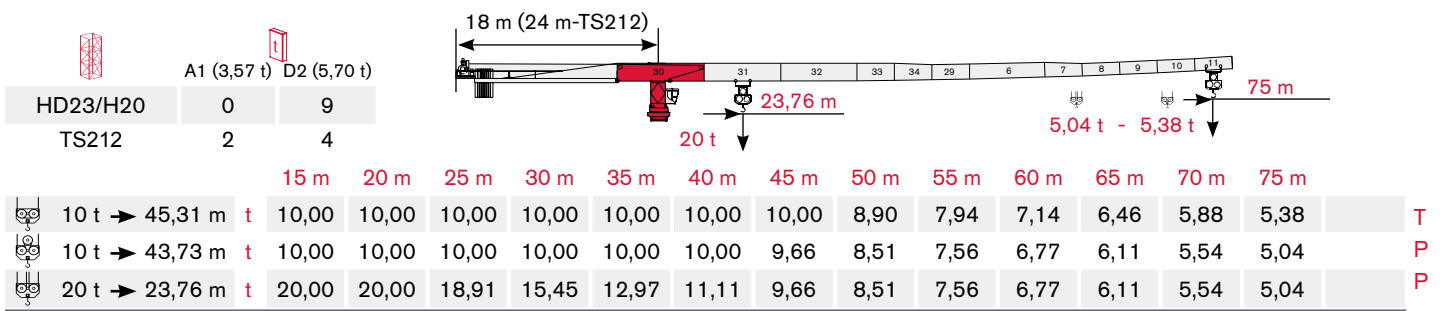
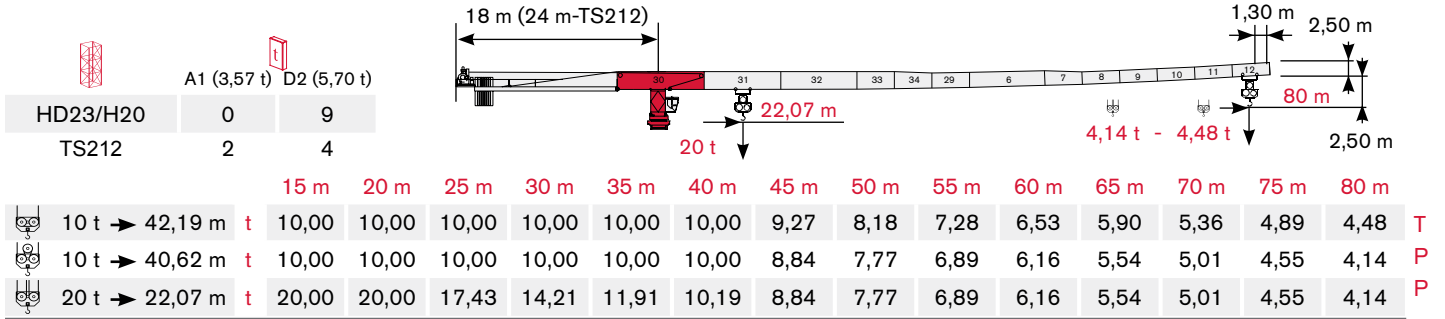

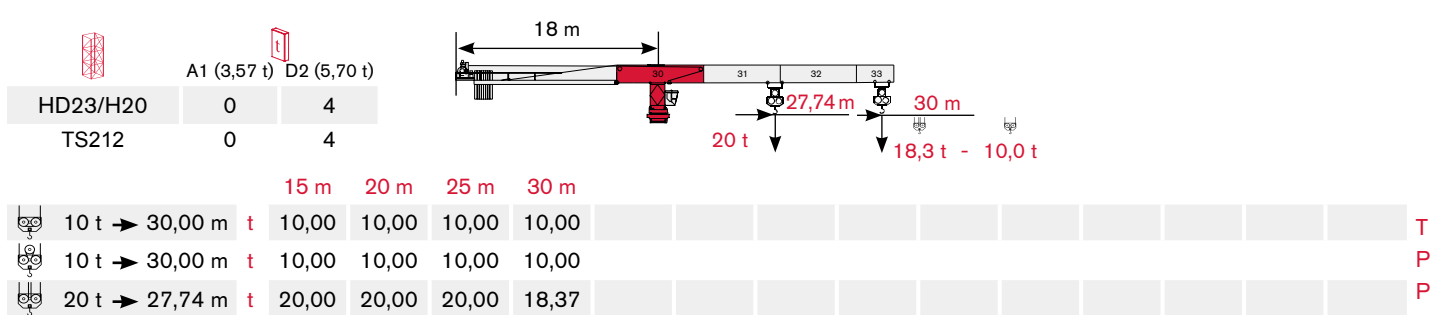
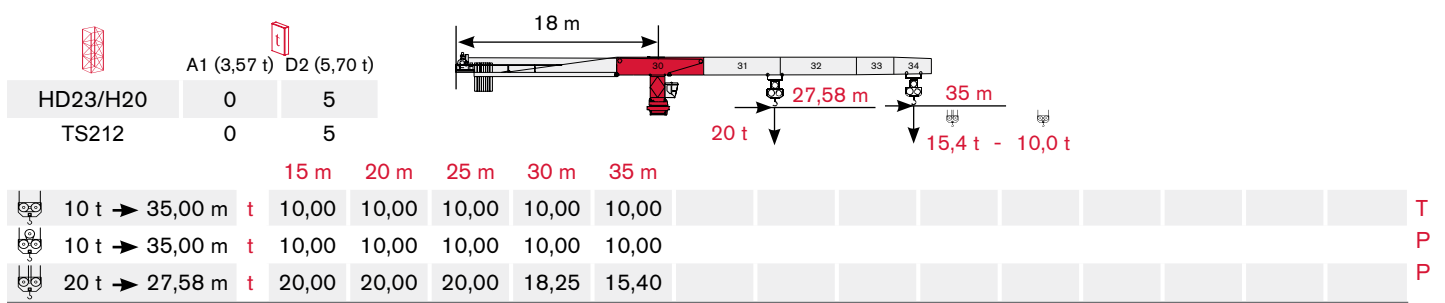
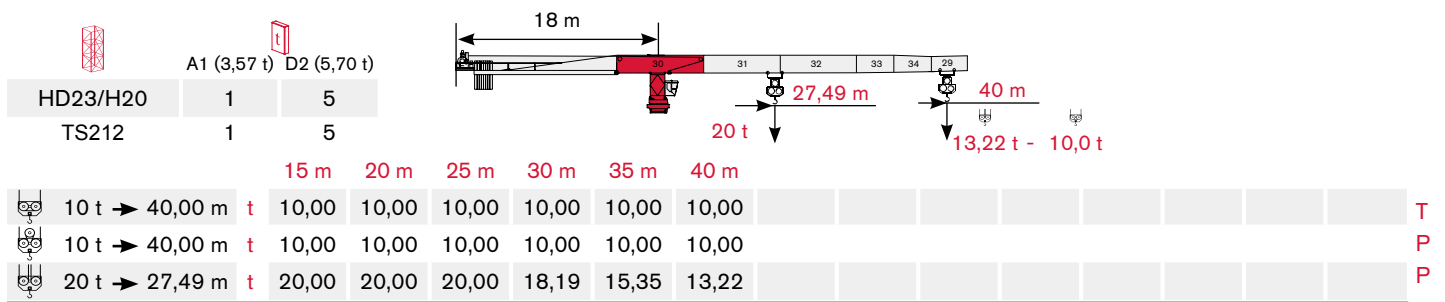
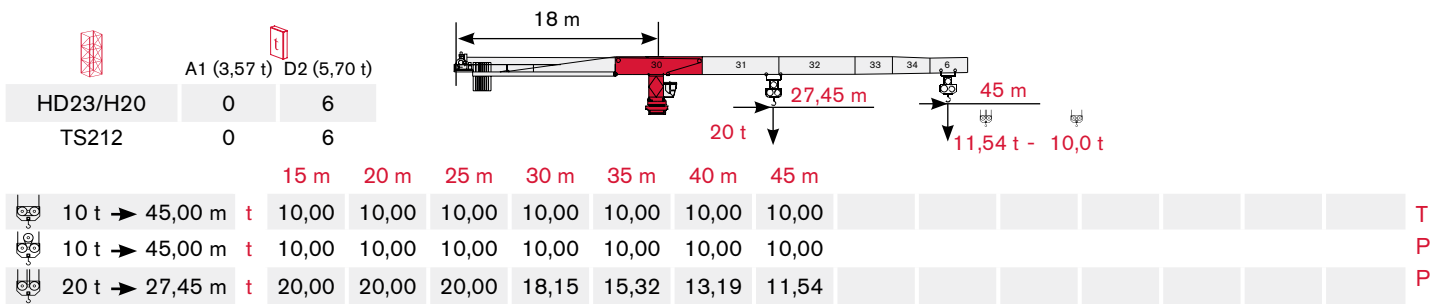
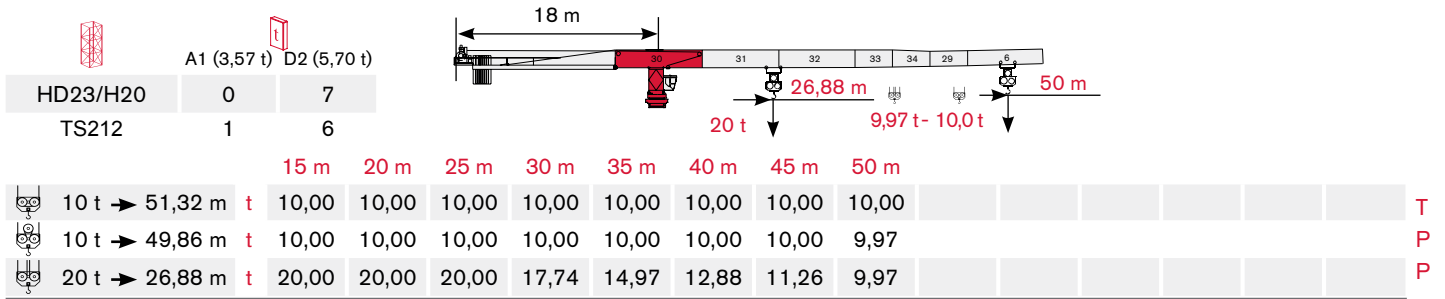
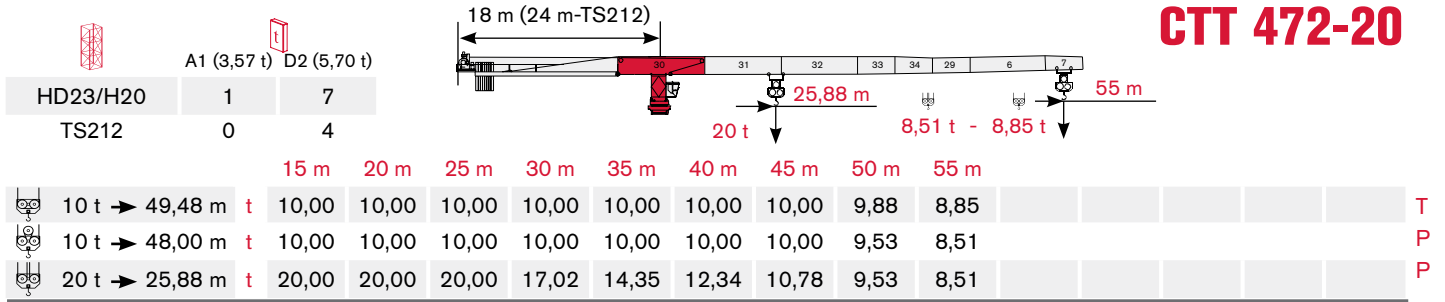

TOWER

Torre · Turm · Tour · Torre · Torre · Башня

Standard Configurations · Installazioni Standard · Standardkonfiguration · Standard Implantations · Implantaciones Standard · Configuração padrão · Стандартная конфигурация крана

H20

Tower: H20 & Basement: RTL

	●	◊
R1	-3470 kN	-2950 kN
R2	2575 kN	2264 kN
	1003 kN	

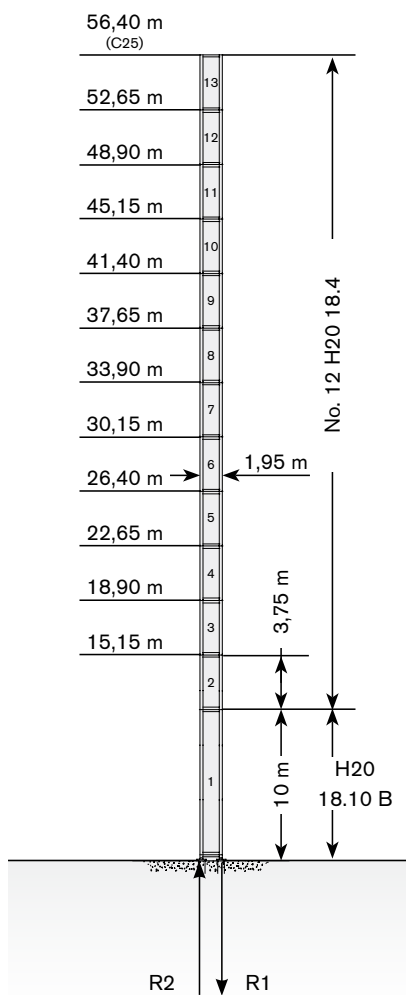

→	max. H (m)	
	FEM 1001	FEM 1005 C25
30->50 m	56,40	56,40
55->80 m	56,40	56,40

Tower: H20 & Basement: FTR

	●	◊
R1	-1723 kN	-1550 kN
R2	0 kN	0 kN
	1051 kN	

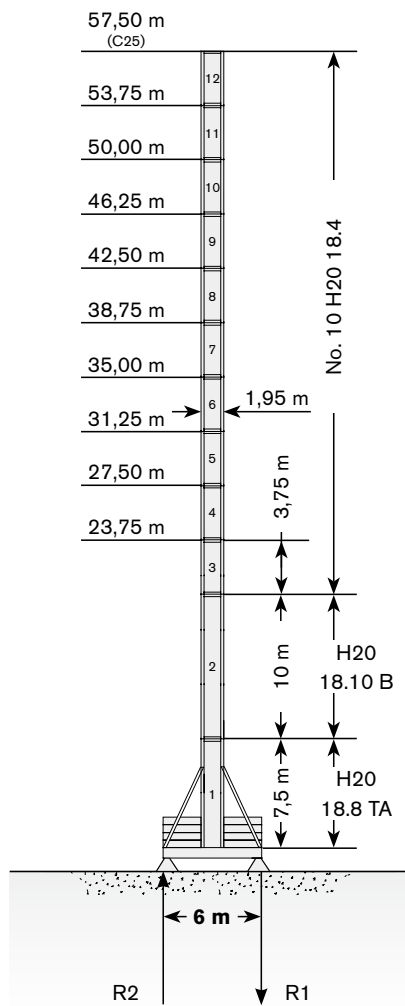

→	max. H (m)	
	FEM 1001	FEM 1005 C25
30->50 m	57,50	57,50
55->80 m	53,75	53,75

Tower: H20 & Basement: TTR

	●	◊
R1	-1738 kN	-1259 kN
R2	0 kN	-35 kN
	964 kN	

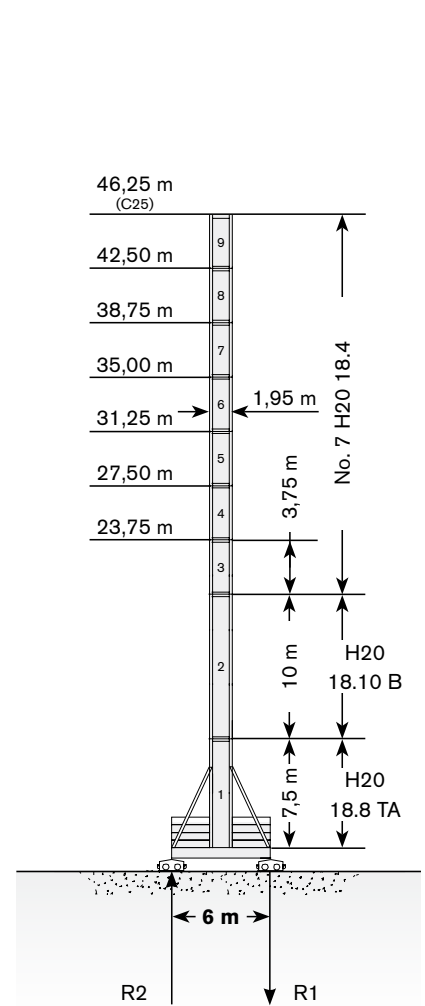

→	max. H (m)	
	FEM 1001	FEM 1005 C25
30->50 m	46,25	46,25
55->80 m	46,25	46,25

Max. under hook height · Altezza max. sotto gancio · Höchste Hakenhöhe · Hauteur maxi. sous crochet · Maxima altura bajo gancho · alt. máx. sob o gancho · макс высота крюка

Different heights and tower combinations are available; please consult us · Altezze diverse e combinazioni di torre sono disponibili; consultateci · Andere Höhen und Turmkombinationen auf Anfrage · Différentes hauteurs et combinaisons de tour sont disponibles; nous consulter · Hay diferentes alturas y combinaciones de torre disponibles. Consultémos · Diferentes alturas e combinações de torres disponíveis; fale conosco · Возможны другие сочетания высоты и конфигурации башни; проконсультируйтесь с нами



Other configurations · Altre Installazioni · Aufstellmöglichkeiten · Autres Implantations · Otras Implantaciones · Outras configurações · Другие конфигурации

Bottom climbing crane · Gru climbing · Kletterkran im Gebäude · Télescope sur dalles · Telescopiaje grúa trepadora · Guindaste automontante interno · Самоподъемный кран

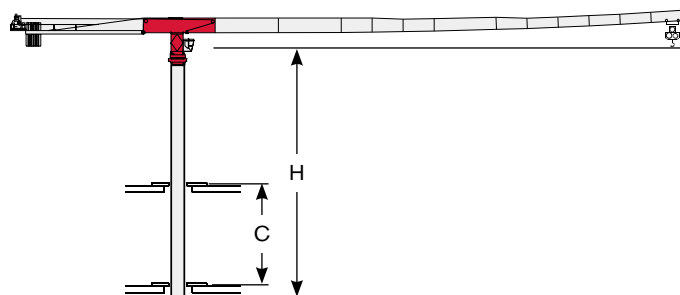

Crane tied to the structure · Gru ancorata · Geankerter Kran · Grue ancrée · Grúa anclada · Guindaste ancorado na estrutura · Кран, крепящийся к сооружению

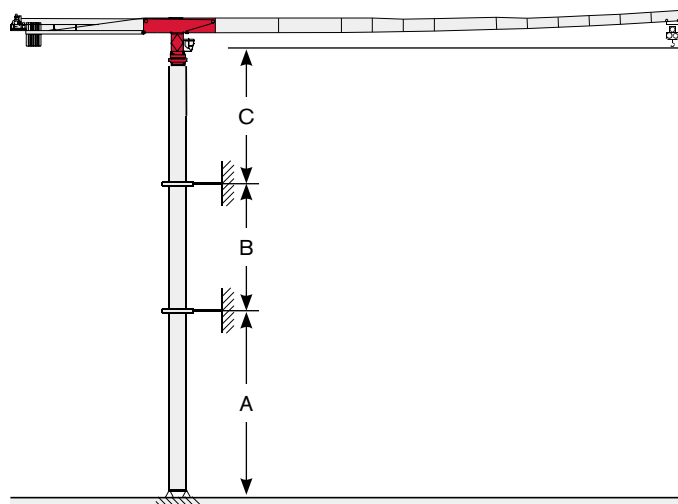

Tower: H20

Jib (m)	C min/max (m)	H min/max (m)
30 > 50	12/16	30/41,25
55 > 80	12/16	30/37,5

Tower: H20 & Basement: RTL

Jib (m)	A min/max (m)	B min/max (m)	C max (m)
all	25/44	18/24	32



Different heights and tower combinations are available; please consult us ▪ Altezze diverse e combinazioni di torre sono disponibili; consultateci ▪ Andere Höhen und Turmkombinationen auf Anfrage ▪ Différentes hauteurs et combinaisons de tour sont disponibles; nous consulter ▪ Hay diferentes alturas y combinaciones de torre disponibles. Consultémos ▪ Diferentes alturas e combinações de torres disponíveis; fale conosco ▪ Возможны другие сочетания высоты и конфигурации башни; проконсультируйтесь с нами

TOWER

Torre · Turm · Tour · Torre · Torre · Башня

Standard Configurations · Installazioni Standard · Standardkonfiguration · Standard Implantations · Implantaciones Standard · Configuração padrão · Стандартная конфигурация крана

HD23

Tower: HD23 & Basement: FP1

	●	◆
R1	-1611 kN	-1760 kN
R2	0 kN	0 kN
	1316 kN	

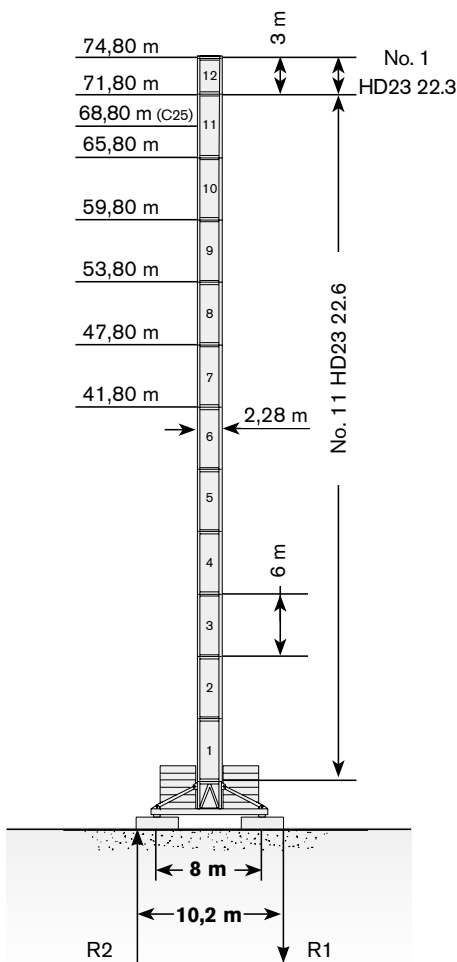

→	max. H (m)	
	FEM 1001	FEM 1005 C25
30->50 m	74,80	68,80
55->80 m	74,80	68,80

Tower: HD23 & Basement: T1

	●	◆
R1	-1598 kN	-1401 kN
R2	0 kN	0 kN
	1248 kN	

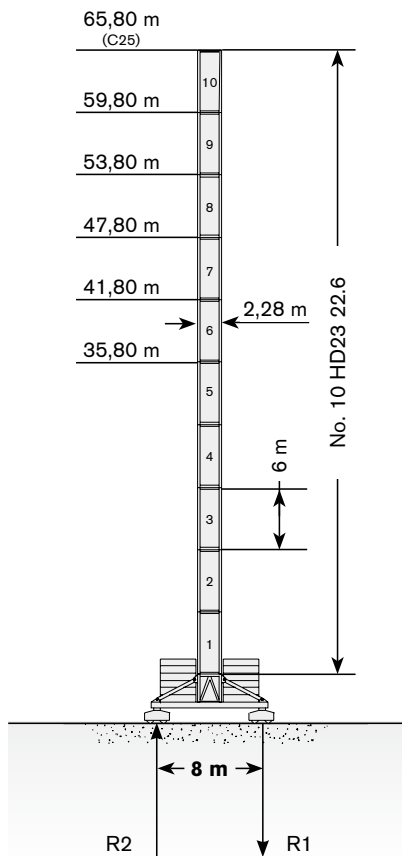

→	max. H (m)	
	FEM 1001	FEM 1005 C25
30->50 m	65,80	65,80
55->80 m	62,80	62,80

Tower: HD23 & Basement: R1

	●	◆
R1	-3610 kN	-3809 kN
R2	2636 kN	2998 kN
	1146 kN	

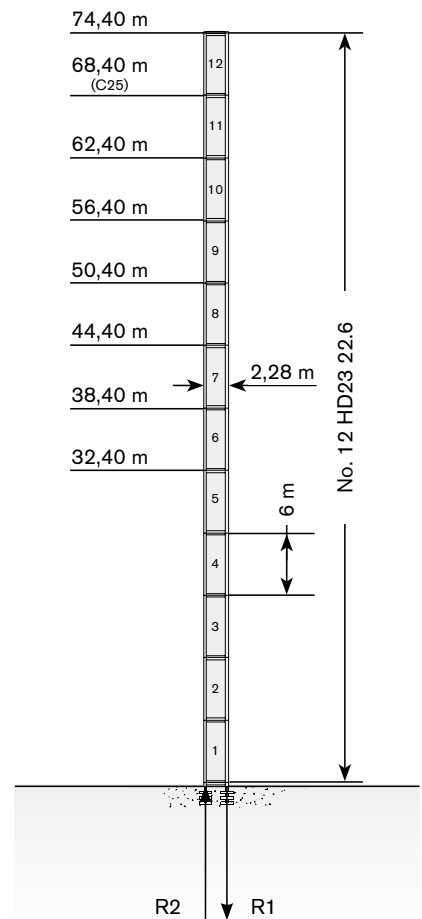

→	max. H (m)	
	FEM 1001	FEM 1005 C25
30->50 m	74,40	68,40
55->80 m	74,40	68,40

Max. under hook height · Altezza max. sotto gancio · Höchste Hakenhöhe · Hauteur maxi. sous crochet · Maxima altura bajo gancho · alt. máx. sob o gancho · макс высота крюка

Different heights and tower combinations are available; please consult us · Altezze diverse e combinazioni di torre sono disponibili; consultateci · Andere Höhen und Turmkombinationen auf Anfrage · Différentes hauteurs et combinaisons de tour sont disponibles; nous consulter · Hay diferentes alturas y combinaciones de torre disponibles. Consúltenos · Diferentes alturas e combinações de torres disponíveis; fale conosco · Возможны другие сочетания высоты и конфигурации башни; проконсультируйтесь с нами



TOWER

Torre · Turm · Tour · Torre · Torre · Башня

Standard Configurations · Installazioni Standard · Standardkonfiguration · Standard Implantations · Implantaciones Standard · Configuração padrão · Стандартная конфигурация крана

HD23

Tower: HD23 & Basement: R3

	●	◊
R1	-4345 kN	-6592 kN
R2	3244 kN	5732 kN
	1398 kN	

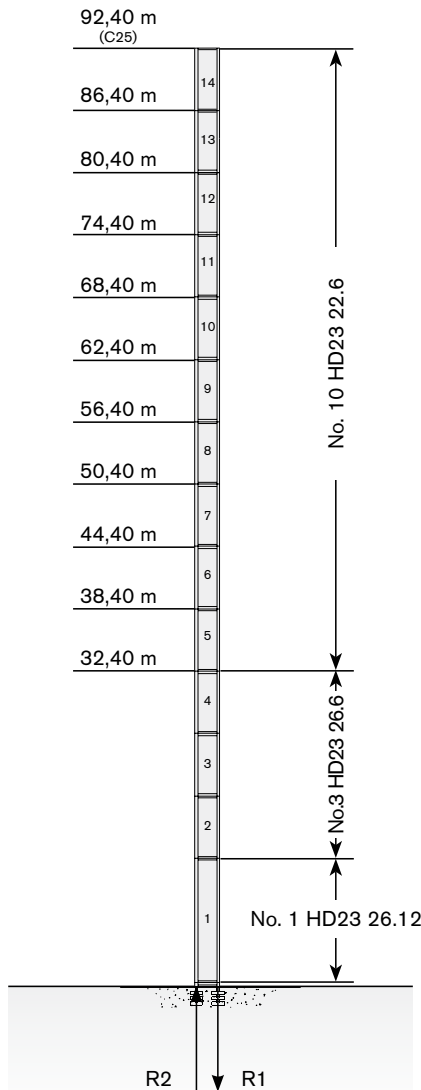

→	max. H (m)	
	FEM 1001	FEM 1005 C25
		
30->50 m	92,40	92,40
55->80 m	92,40	86,40

Max. under hook height · Altezza max. sotto gancio · Höchste Hakenhöhe · Hauteur maxi. sous crochet · Maxima altura bajo gancho · alt. máx. sob o gancho · макс высота крюка

Different heights and tower combinations are available; please consult us · Altezze diverse e combinazioni di torre sono disponibili; consultateci · Andere Höhen und Turmkombinationen auf Anfrage · Différentes hauteurs et combinaisons de tour sont disponibles; nous consulter · Hay diferentes alturas y combinaciones de torre disponibles. Consultémos · Diferentes alturas e combinações de torres disponíveis; fale conosco · Возможны другие сочетания высоты и конфигурации башни; проконсультируйтесь с нами



Other configurations · Altre Installazioni · Aufstellmöglichkeiten · Autres Implantations · Otras Implantaciones · Outras configurações · Другие конфигурации

Bottom climbing crane · Gru climbing · Kletterkran im Gebäude · Télescope sur dalles · Telescopage grúa trepadora · Guindaste automontante interno · Самоподъемный кран

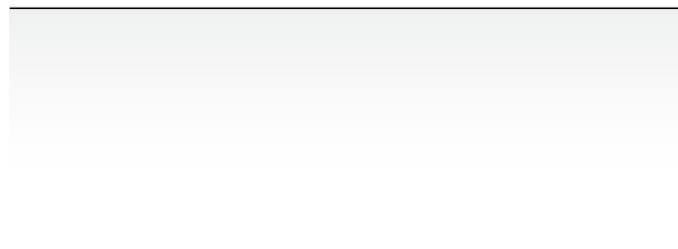
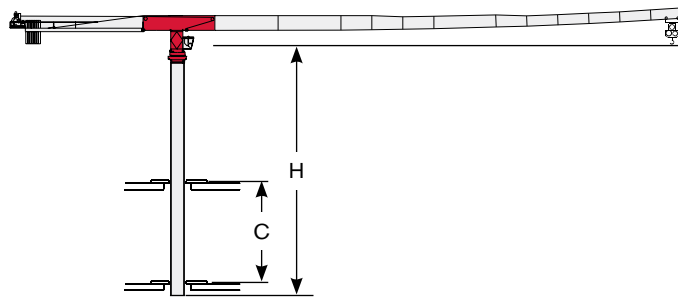

Tower: HD23

Jib (m)	C min/max (m)	H min/max (m)
all	10/16	36/54

Crane tied to the structure · Gru ancorata · Geankerter Kran · Grue ancrée · Grúa anclada · Guindaste ancorado na estrutura · Кран, крепящийся к сооружению

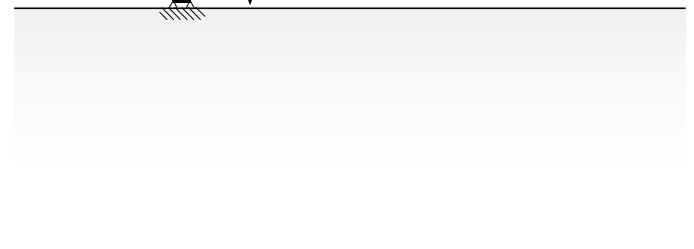
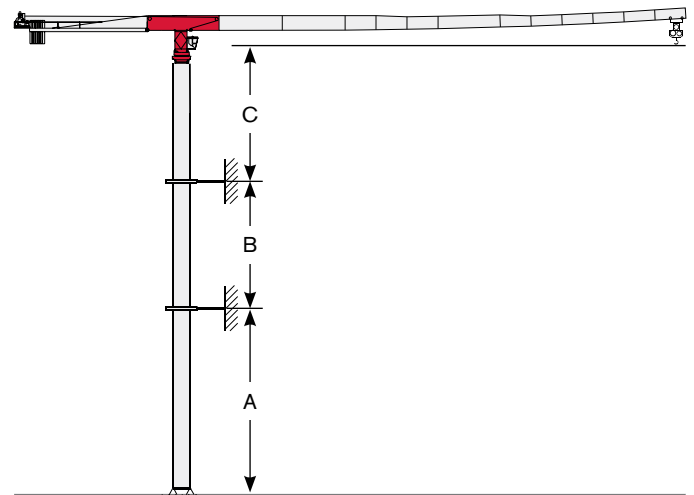

Tower: HD23 & Basement: R2

Jib (m)	A min/max (m)	B min/max (m)	C max (m)
all	42/66	24/42	42



Different heights and tower combinations are available; please consult us ▪ Altezze diverse e combinazioni di torre sono disponibili; consultateci ▪ Andere Höhen und Turmkombinationen auf Anfrage ▪ Différentes hauteurs et combinaisons de tour sont disponibles; nous consulter ▪ Hay diferentes alturas y combinaciones de torre disponibles. Consultémos ▪ Diferentes alturas e combinações de torres disponíveis; fale conosco ▪ Возможны другие сочетания высоты и конфигурации башни; проконсультируйтесь с нами

TOWER

Torre · Turm · Tour · Torre · Torre · Башня

Standard Configurations · Installazioni Standard · Standardkonfiguration · Standard Implantations · Implantaciones Standard · Configuração padrão · Стандартная конфигурация крана

TS212

Tower: TS212 & Basement: R4

	●	◊
R1	-2709 kN	-2528 kN
R2	1919 kN	1869 kN
	1020 kN	

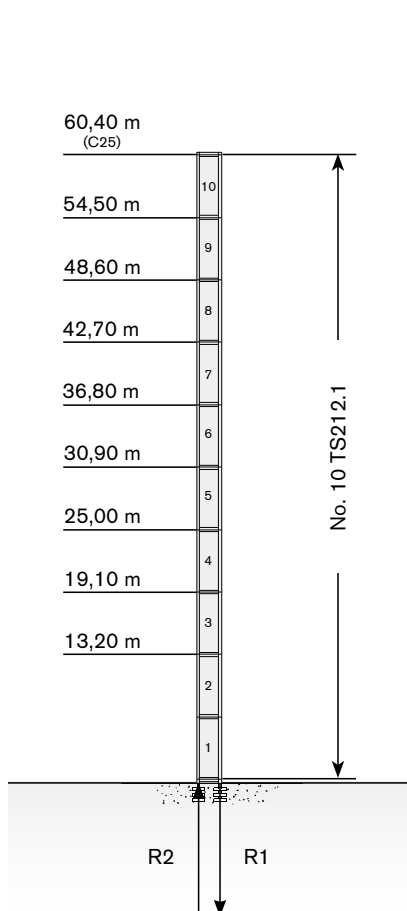

→	max. H (m)	
	FEM 1001	FEM 1005 C25
30->50 m	60,40	60,40
55->80 m	60,40	60,40

Tower: TS212 & Basement: FP4

	●	◊
R1	-1372 kN	-1455 kN
R2	0 kN	0 kN
	1260 kN	

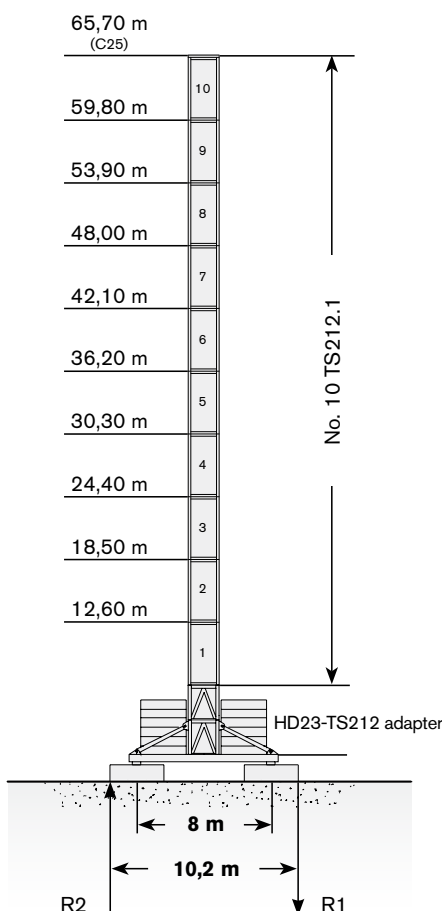

→	max. H (m)	
	FEM 1001	FEM 1005 C25
30->50 m	65,70	65,70
55->80 m	65,70	65,70

Tower: TS212 & Basement: T4

	●	◊
R1	-1331 kN	-952 kN
R2	0 kN	-69 kN
	1180 kN	

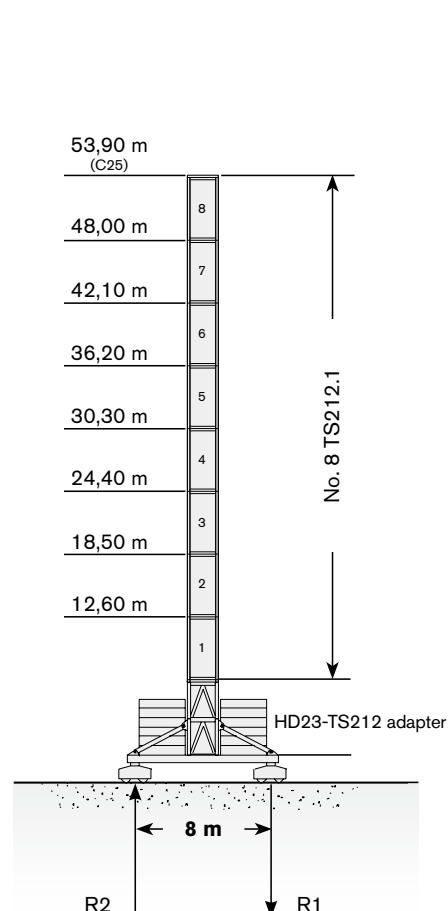

→	max. H (m)	
	FEM 1001	FEM 1005 C25
30->50 m	53,90	53,90
55->80 m	53,90	53,90

Max. under hook height · Altezza max. sotto gancio · Höchste Hakenhöhe · Hauteur maxi. sous crochet · Maxima altura bajo gancho · alt. máx. sob o gancho · макс высота крюка

Different heights and tower combinations are available; please consult us · Altezze diverse e combinazioni di torre sono disponibili; consultateci · Andere Höhen und Turmkombinationen auf Anfrage · Différentes hauteurs et combinaisons de tour sont disponibles; nous consulter · Hay diferentes alturas y combinaciones de torre disponibles. Consultémos · Diferentes alturas e combinações de torres disponíveis; fale conosco · Возможны другие сочетания высоты и конфигурации башни; проконсультируйтесь с нами

Other configurations · Altre Installazioni · Aufstellmöglichkeiten · Autres Implantations · Otras Implantaciones · Outras configurações · Другие конфигурации

Crane tied to the structure · Gru ancorata · Geankerter Kran · Grue ancrée · Grúa anclada · Guindaste ancorado na estrutura · Кран, крепящийся к сооружению

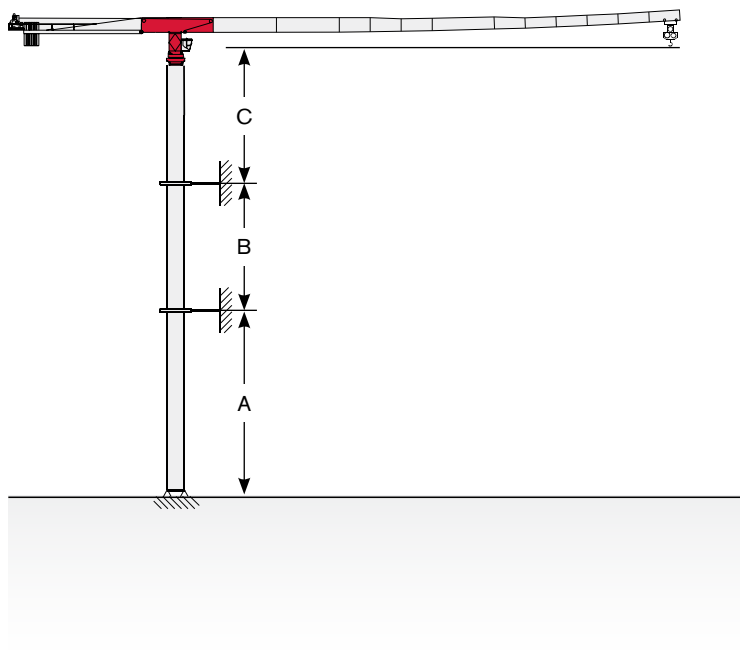





Tower: TS212

Jib (m)	A min/max (m)	B min/max (m)	C max (m)
all	30/53	17,7/35,4	44

MECHANISMS





Meccanismi · Antriebe · Mécanismes · Mecanismos · Mecanismo · Механизм

Power supply · Alimentazione · Stromversorgung · Alimentation · Suministro eléctrico · Requisitos de energia · Требования по питанию

	80 AFC 100	 186 kVA*	 400V - 50Hz / 460V - 60Hz	 2000/14/CE modificata
---	------------	--	---	---

* Average consumption · Consumo medio · Durchschnittsverbrauch · Consommation moyenne · Consumo medio · Consumo médio · Среднее потребление

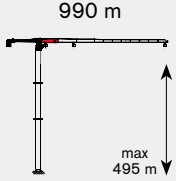

Hoisting · Sollevamento · Heben · Levage · Elevación · Elevação · Подъем

			t	m/min	kW	
	80 AFC 100 D2		10	0 → 38	80	
			8,5	0 → 45		
			5,5	0 → 64		
			3,5	0 → 90		
			0,7	0 → 190		
			20	0 → 19		
			17	0 → 22		
			11	0 → 32		
			7	0 → 45		
			1,4	0 → 95		

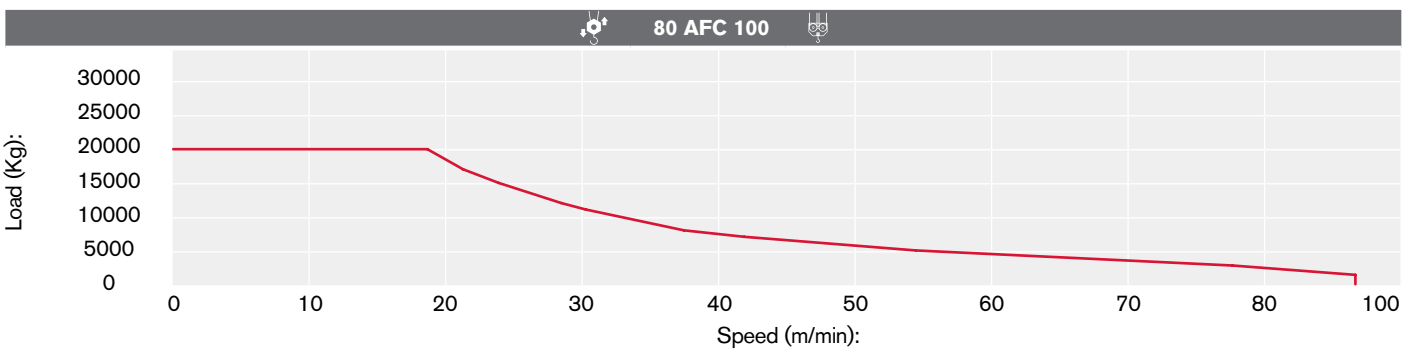
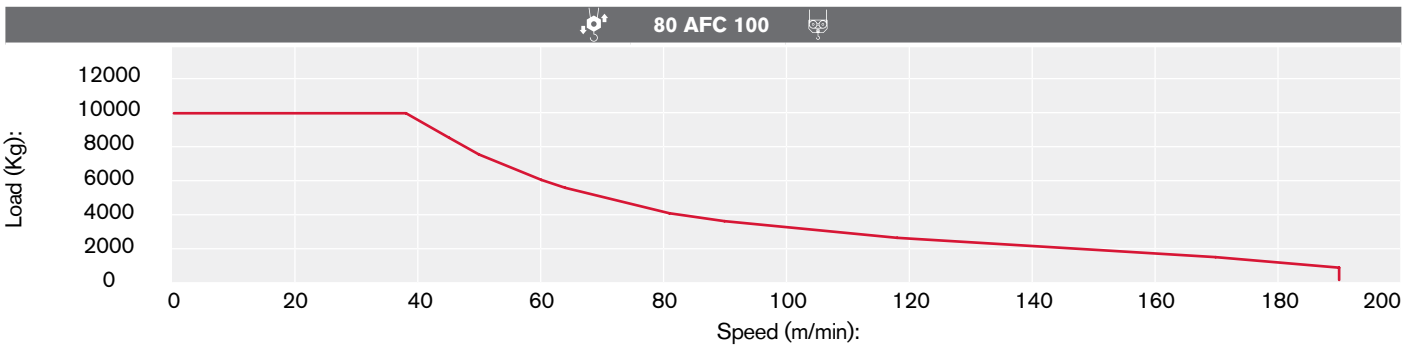

Hoisting Speed · Velocità di Sollevamento · Heben Geschwindigkeit · Vitesse de Levage · Velocidad de Elevación · Velocidade de içamento · Скорость подъема

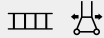
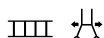

Additional Specifications · Altre movimentazioni · Weitere Leistungsdaten · Spécifications additionnelles · Otras prestaciones · Especificações adicionais · Дополнительные спецификации

	DVF 5 15 D5	0 → 12,5 → 47 → 110 m/min	15 kW
	SVF 2 2 19	0,9 r.p.m.	2 x 18,5 kW
	TSR 2RG 4M8	12 → 24 m/min (50 Hz) 14 → 28 m/min (60 Hz)	4 x 80 Nm
	TSR 4RG 4M8	12 → 24 m/min (50 Hz) 14 → 28 m/min (60 Hz)	4 x 80 Nm

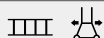
Tower height max.

		T1	T2	T2 C25
	TSR 2RG 4M8	35,6 m	48 m	42 m
	TSR 4RG 4M8	> 35,6 m	> 48 m	> 42 m



TRANSPORTATION

Trasporto · Transport · Transport · Transporte · Transporte · Транспортировка

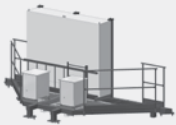

Packing list

Undercarriage

CTT 472-20 H20	DESCRIPTION · DESCRIZIONE · BESCHREIBUNG · DESCRIPTION · DESCRIPCIÓN · DESCRIÇÃO · ОПИСАНИЕ	LENGTH · LUNGHEZZA · LÄNGE · LONGUEUR · LONGITUD · COMPRIMENTO · ДЛИНА	WIDTH · LARGHEZZA · BREITE · LARGEUR · ANCHURA · LARGURA · ШИРИНА	HEIGHT · ALTEZZA · HÖHE · HAUTEUR · ALTURA · ALTURA · · ВИСОТА	QUANTITY · QUANTITÀ · MENGE · QUANTITÉ · · CANTIDAD · QUANTIDADE · КОЛИЧЕСТВО	WEIGHT · PESO · GEWICHT · POIDS · PESO · PESO · BEC
	STRUT MOUNTING TOWER SECTION H20 18.8TA FOR 6×6 m UNDERCARRIAGE	7,50 m	2,30 m	2,30 m	1	6660 kg*
	6×6 m UNDERCARRIAGE LONG BEAM	8,95 m	0,50 m	1,05 m	1	2088 kg
	6×6 m UNDERCARRIAGE SHORT BEAM	4,4 m	0,5 m	1,05 m	2	1010 kg
	6×6 m UNDERCARRIAGE JOINING SLEEPER	5,5 m	0,15 m	0,48 m	2	280 kg
	6×6 m UNDERCARRIAGE JOINING SLEEPER	5,5 m	0,15 m	0,48 m	2	220 kg
	6×6 m UNDERCARRIAGE STRUT	5,10 m	0,24 m	0,30 m	4	500 kg
CTT 472-20 HD23						
	8×8 m UNDERCARRIAGE STRUT MOUNTING TOWER SECTION	2,90 m	2,90 m	2,90 m	1	9150 kg
	8×8 m UNDERCARRIAGE STRUT	4,30 m	0,30 m	2,25 m	4	1820 kg
	8×8 m UNDERCARRIAGE INTERNAL BEAM	4,00 m	0,16 m	0,33 m	4	210 kg
	8×8 m UNDERCARRIAGE EXTERNAL BEAM	5,96 m	0,30 m	0,33 m	4	626 kg
	10×10 m UNDERCARRIAGE STRUT MOUNTING TOWER SECTION	3,00 m	3,00 m	3,10 m	1	10450 kg
	10×10 m LEFT + RIGHT UNDERCARRIAGE STRUT	5,70 m	2,60 m	0,70 m	2 left + 2 right	3825 kg
	CROSSBEAM FOR TRAVELLING 10×10 m UNDERCARRIAGE	7,00 m	2,20 m	0,40 m	2	2030 kg

CTT 472-20 HD23	DESCRIPTION · DESCRIZIONE · BESCHREIBUNG · DESCRIPTION · DESCRIPCIÓN · DESCRIÇÃO · ОПИСАНИЕ	LENGTH · LUNGHEZZA · LÄNGE · LONGUEUR · LONGITUD · COMPRIMENTO · ДЛИНА	WIDTH · LARGHEZZA · BREITE · LARGEUR · ANCHURA · LARGURA · ШИРИНА	HEIGHT · ALTEZZA · HÖHE · HAUTEUR · ALTURA · ALTURA · ВЫСОТА	QUANTITY · QUANTITÀ · MENGE · QUANTITÉ · CANTIDAD · QUANTIDADE · КОЛИЧЕСТВО	WEIGHT · PESO · GEWICHT · POIDS · PESO · PESO · BEC
	10×10 m UNDERCARRIAGE ELECTRICAL BOX SUPPORT PLATFORM FOR TVF 4RT 4M9 TRAVELLING DRIVE UNIT	5,70 m	2,20 m	2,40 m	1	1300 kg
	10×10 m UNDERCARRIAGE ELECTRICAL BOX SUPPORT PLATFORM FOR TSR 4RG 4M8 TRAVELLING DRIVE UNIT	5,60 m	2,10 m	3,70 m	1	645 kg



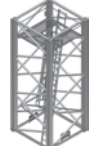
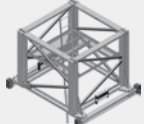

Tower

CTT 472-20 H20						
	H20 18.10 B TOWER SECTION	10,0 m	2,00 m	1,95 m	1	7000 kg*
	H20 18.4 TOWER SECTION	3,75 m	2,00 m	1,95 m	1	2955 kg*
CTT 472-20 TS212						
	MAST SECTION ADAPTER HD23 - TS212	2,98 m	2,38 m	2,00 m	1	3235 kg
	TOWER MAST SECTION TS212	5,94 m	2,37 m	2,44 m	1	4220 kg
	TOWER MAST SECTION TSK212	2,37 m	2,98 m	2,02 m	1	2800 kg



* inclusive of ladders, platforms and assembly equipment

TRANSPORTATION

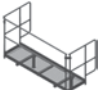

Trasporto · Transport · Transport · Transporte · Transporte · Транспортировка

CTT 472-20 HD23	DESCRIPTION · DESCRIZIONE · BESCHREIBUNG · DESCRIPTION · DESCRIPCIÓN · DESCRIÇÃO · ОПИСАНИЕ	LENGTH · LUNGHEZZA · LÄNGE · LONGUEUR · LONGITUD · COMPRIMENTO · ДЛИНА	WIDTH · LARGHEZZA · BREITE · LARGEUR · ANCHURA · LARGURA · ШИРИНА	HEIGHT · ALTEZZA · HÖHE · HAUTEUR · ALTURA · ALTURA · · ВИСОТА	QUANTITY · QUANTITÀ · MENGE · QUANTITÉ · · CANTIDAD · · CANTIDADE · КОЛИЧЕСТВО	WEIGHT · PESO · GEWICHT · POIDS · PESO · PESO · ВЕС
	TOWER SECTION HD23 26.6	6,00 m	2,34 m	2,32 m	1	6300 kg*
	TOWER SECTION HD23 26.3	3,00 m	2,34 m	2,32 m	1	3658 kg
	TOWER SECTION HD23 22.6	6,00 m	2,28 m	2,29 m	1	4675 kg*
	TOWER SECTION HD23 22.3	3,00 m	2,29 m	2,28 m	1	2660 kg*
	SLEWING UNIT CTT472-20 HD23	3,00 m	2,30 m	2,40 m	1	10970 kg
	SLEWING UNIT PLATFORM	2,30 m	0,70 m	1,50 m	1	132 kg

Cab

CTT 472-20						
	CAB PLATFORM	5,00 m	2,30 m	2,70 m	1	2050 kg
	CAB MAST	3,60 m	2,00 m	2,00 m	1	2650 kg

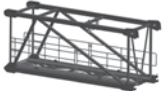
Upper Part

CTT 472-20						
	COUNTER JIB	9,80 m	2,10 m	2,30 m	1	3865 kg
	SECTION CB TS212 - 472	6,3 m	1,99 m	2,55 m	1	3500 kg
	WINCH COUNTERJIB 80 AFC 100 D2	3,67 m	2,20 m	2,46 m	1	R01 6200 kg** R02 5600 kg**
	COUNTER JIB PLATFORMS UNIT	3,50 m	0,80 m	0,40 m	1	782 kg

Upper Part

CTT 472-20	DESCRIPTION · DESCRIZIONE · BESCHREIBUNG · DESCRIPTION · DESCRIÇÃO · DESCRIÇÃO · ОПИСАНИЕ	LENGTH · LUNGHEZZA · LÄNGE · LONGUEUR · LONGITUD · COMPRIMENTO · ДЛИНА	WIDTH · LARGHEZZA · BREITE · LARGEUR · ANCHURA · LARGURA · ШИРИНА	HEIGHT · ALTEZZA · HÖHE · HAUTEUR · ALTURA · ALTURA · ВЫСОТА	QUANTITY · QUANTITÀ · MENGE · QUANTITÉ · CANTIDAD · QUANTIDADE · КОЛИЧЕСТВО	WEIGHT · PESO · GEWICHT · POIDS · PESO · PESO · ВЕС
	JIB SECTION - 30	12,00 m	2,20 m	2,60 m	1	10000 kg
	JIB SECTION - 31	10,50 m	1,90 m	2,50 m	1	4700 kg
	JIB SECTION - 32	10,00 m	1,90 m	2,50 m	1	3750 kg
	JIB SECTION - 33	5,00 m	1,90 m	2,50 m	1	1750 kg
	JIB SECTION - 34	5,00 m	1,90 m	2,50 m	1	1615 kg
	JIB SECTION - 29	5,00 m	1,90 m	2,30 m	1	1532 kg
	JIB SECTION - 06	10,30 m	1,90 m	2,20 m	1	1915 kg
	JIB SECTION - 07	5,28 m	1,90 m	2,18 m	1	900 kg
	JIB SECTION - 08	5,25 m	1,87 m	1,86 m	1	780 kg
	JIB SECTION - 09	5,20 m	1,87 m	1,86 m	1	640 kg
	JIB SECTION - 10	5,20 m	1,90 m	1,86 m	1	510 kg
	JIB SECTION - 11	5,20 m	1,90 m	1,90 m	1	452 kg
	JIB SECTION - 12	5,20 m	1,90 m	1,80 m	1	380 kg
	JIB POINT	2,10 m	1,20 m	1,60 m	1	270 kg
	TROLLEY	2,40 m	2,30 m	1,50 m	1	672 kg
	HOIST BLOCK UNIT	1,60 m	0,60 m	1,65 m	1	887 kg max

* inclusive of ladders, platforms and assembly equipment

** without rope

TEREX CRANES

Tower Cranes

Via delle Innovazioni, 17
33074 Fontanafredda (PN)
Italy

Ph: +39 0434 989111
Email: info.cranes@terex.com

Rough Terrain Cranes

Via Cassoletta, 76 - Fraz. Crespellano
40053 Valsamoggia (BO)
Italy

Ph: +39 051 6501011
Email: info.cranes@terex.com

December 2019. Product specifications and prices are subject to change without notice or obligation. The photographs and/or drawings in this document are for illustrative purposes only. Refer to the appropriate Operator's Manual for instructions on the proper use of this equipment. Failure to follow the corresponding Operator's Manual when using our equipment or to otherwise act responsibly may result in serious injury or death. The only warranty applicable to our equipment is the standard written warranty applicable to the particular product and sale and Terex makes no other warranty, express or implied. Products and services listed may be trademarks, service marks or trade-names of Terex Corporation and/or its subsidiaries in the USA and other countries. All rights are reserved. Terex, the Terex Crown design and Works For You are trademarks of Terex Corporation or its subsidiaries.

Dicembre 2019. Specifiche e prezzi dei prodotti sono soggetti a modifica senza preavviso o altro obbligo. Le fotografie e i disegni in questo documento hanno esclusivamente scopo illustrativo. Consulta il Manuale dell'operatore pertinente per trovare istruzioni per l'utilizzo corretto di questo macchinario. La mancata osservanza delle istruzioni contenute nel relativo Manuale dell'operatore durante l'uso del macchinario e altri comportamenti irresponsabili possono provocare gravi lesioni, anche mortali. L'unica garanzia applicabile ai nostri macchinari è la garanzia scritta standard applicabile al particolare prodotto e alla particolare vendita e Terex è esonerata dal fornire qualsiasi altra garanzia, esplicita o implicita. I prodotti e servizi elencati possono essere dei marchi di fabbrica, marchi di servizio o nomi commerciali di Terex Corporation, e/o delle rispettive società affiliate negli Stati Uniti d'America e in molte altre nazioni. Tutti i diritti riservati. Terex, il marchio Terex Crown e Works for You sono marchi di proprietà di Terex Corporation o delle sue società affiliate.

Dezember 2019. Irrtum und Änderungen der Produktspezifikationen vorbehalten. Die in diesem Dokument enthaltenen Fotos und/oder Zeichnungen dienen rein anschaulichen Zwecken. Für den sachgemäßen Gebrauch der Maschinen ist das entsprechende Bedienerhandbuch heranzuziehen. Unsachgemäßer Umgang mit bzw. unsachgemäßer Einsatz unserer Maschinen kann zu schweren gesundheitlichen Schäden bis hin zum Tod führen. Für unsere Produkte wird ausschließlich die entsprechende, schriftlich niedergelegte Standardgarantie gewährt. Terex leistet keinerlei darüber hinausgehende Garantie, weder ausdrücklich noch stillschweigend. Die genannten Produkte und Dienstleistungen sind in den USA und anderen Ländern ggf. Marken, Dienstleistungsmarken oder Handelsnamen der Terex Corporation und/oder ihrer Tochtergesellschaften. Alle Rechte vorbehalten. Terex, das Terex Kronenlogo und Works For You sind Marken in Eigentum der Terex Corporation bzw. ihrer Tochtergesellschaften.

Décembre 2019. Les caractéristiques et prix des produits peuvent faire l'objet de modifications sans notification préalable. Les photographies ou dessins présentés dans ce document servent uniquement à des fins d'illustration. Pour connaître les instructions relatives à l'utilisation correcte de cet équipement, veuillez vous référer au manuel de l'utilisateur correspondant. Le non-respect du manuel d'utilisateur correspondant lors de l'utilisation de notre équipement ou des actes irresponsables risquent de provoquer de graves blessures, voire un décès. La seule garantie applicable à nos équipements est la garantie écrite standard applicable au produit et à la vente spécifiques. Terex ne délivre aucune autre garantie, expresse ou implicite. Les produits et les services mentionnés peuvent être des marques, des marques de service ou des appellations commerciales de Terex Corporation et/ou de ses filiales aux États-Unis et dans d'autres pays. Tous droits réservés. Terex, le design Terex Crown et Works For You sont des marques déposées de Terex Corporation ou de ses filiales.

Diciembre 2019. Las especificaciones y los precios de los productos están sujetos a cambios sin necesidad de previo aviso ni ninguna otra obligación. Las fotografías y/o dibujos de este documento tienen un fin meramente ilustrativo. Consulte el correspondiente manual de instrucciones del operario para obtener más información sobre el uso correcto de esta maquinaria. No respetar el manual del operario al utilizar la maquinaria o actuar de forma irresponsable puede provocar lesiones graves e incluso mortales. La única garantía aplicable a nuestra maquinaria es la garantía escrita estándar de cada producto y venta. Terex no amplía dicha garantía de forma expresa ni implícita. Los productos y servicios mencionados pueden ser marcas comerciales, marcas de servicio o nombres de marca de Terex Corporation o de alguna de sus filiales en Estados Unidos y otros países. Todos los derechos reservados. Terex, el diseño de la corona Terex y Works For You son marcas registradas de Terex Corporation o de sus filiales.

Dezembro 2019. Especificações e preços dos produtos sujeitos a alteração sem aviso prévio ou obrigações. As fotografias e/ou desenhos neste documento são apenas para fins ilustrativos. Consulte o respectivo Manual do Operador para instruções sobre o uso correto deste equipamento. Deixar de acompanhar o respectivo Manual do Operador ao usar o nosso equipamento ou, por qualquer outra forma, deixar de agir de maneira responsável pode resultar em lesões corporais graves ou a morte. A única garantia aplicável ao nosso equipamento é a garantia padrão por escrito correspondente ao produto específico vendido. A Terex não dá outras garantias, expressas ou implícitas. Os produtos e serviços listados podem ser marcas comerciais, marcas de serviço ou nomes-fantasia da Terex Corporation e/ou suas subsidiárias nos EUA e em outros países. Todos os direitos reservados. Terex, o desenho da Coroa Terex e a expressão Works For You são marcas comerciais da Terex Corporation ou suas subsidiárias.

декабрь 2019 г. года Технические характеристики и цены могут изменяться без предварительного уведомления и без каких-либо обязательств для производителя. Фотографии и (или) чертежи в настоящем документе служат только в качестве иллюстраций. Инструкции по надлежащей эксплуатации данного оборудования см. в соответствующем руководстве для оператора. Невыполнение указаний соответствующих руководств для оператора при эксплуатации оборудования или другие безответственные действия могут повлечь серьезные травмы или смерть. Единственной гарантией, действующей в отношении нашего оборудования, является стандартная форма письменной гарантии на данный тип оборудования и на условия его продажи. Terex не дает никаких других гарантий: ни ясно выраженных, ни подразумеваемых. Перечисленные продукты и услуги могут быть торговыми марками, знаками обслуживания или торговыми наименованиями Terex Corporation и / или ее дочерних компаний в США и других странах. Все права защищены. Terex, изображение короны Terex и Works for You являются торговыми марками, принадлежащими корпорации Terex или ее дочерним компаниям.



www.terex.com/cranes

Brochure Reference: TC-DS-M-E/F/G//S/P/R-CTT 472-20-12/19



WORKS FOR YOU.™