

The PRO-CAN PUMP is a facility that can feed materials cleanly without mixing foreign substances or air bubbles by transferring the material contained in the container as it is. High-viscosity liquids can be transported with high precision over long distances, and the materials in a fixed quantity are precisely fed by adopting an electric motor method instead of a drive method using air.

It is very economical because it can use up to 1% of the remaining liquid in the container by applying a special follower plate developed by our company. With the application of the AUTO AIR VENT, air bubbles are automatically removed without additional air bubbles when supplying and replacing materials. Various lineups are provided according to the size of the CAN container. Please consult with our sales manager to select the correct specifications.

PRO-CP (1K)

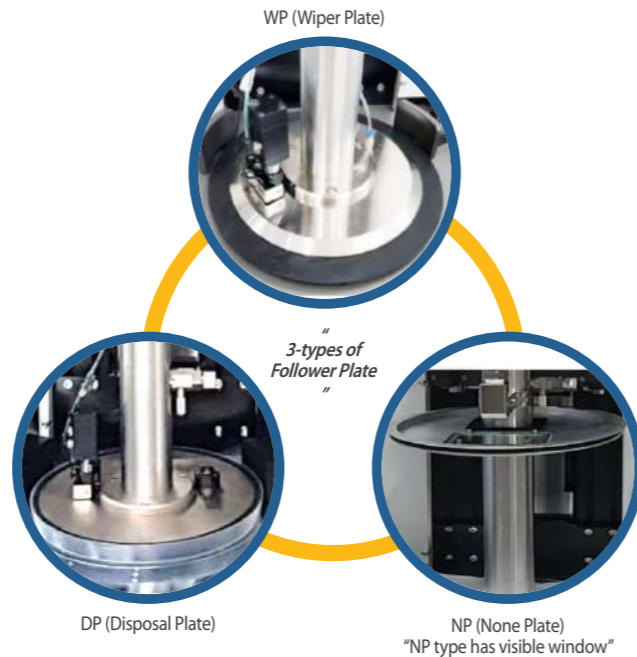

PRO-CP (1K)

Model	PRO-CP20
Can Size	20kg
Weight	≈150kg
Air Pressure	0.4~0.5MPa (Humidity 5% less than, Air Filter 5μ less than)
Power	AC220V(±10%), 50/60Hz
Power Consumption	max 2.6kW
Display	5inch TFT LCD
Operating Method	Touch screen, Button S/W
Operating Mode	AUTO/MANUAL/TEST
Viscosity	1~500,000(cps)
Dosing Pressure	5.0MPa
Displacement	5.0ml/rev
Flux	max 300ml/min
Accuracy	±1%
Min. Feeding vol	25.0ml/min
Motor Speed	1~150rpm (60rpm Recommended)
Inlet Port	One touch fitting PC (∅8)
Outlet Port	BSPT 3/8, 1/2, 3/4, 1
Material of Stator	FFKM/EPDM
Temperature	0~50°C (Avoid direct sunlight)
Humidity	10~85%RH
Vibration Resistance	Less than 0.5G
Comm. Connector	LAN(Modbus TCP), RS485(Modbus RTU)
Follower Plate	WP(Wiper Plate) / DP(Disposal Plate) / NP(None Plate)

Dimension

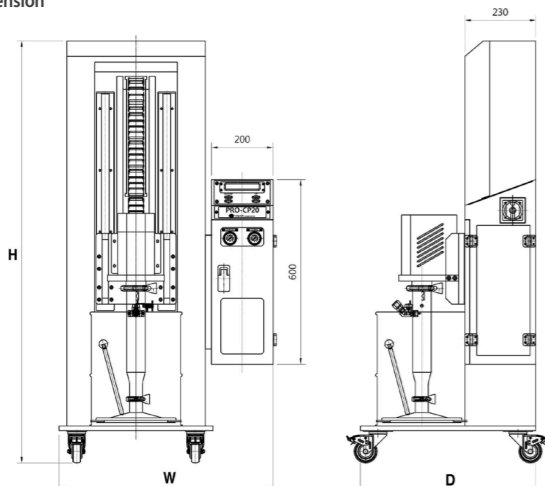

PRO-CPD (2K)



PRO-CPD (2K)

Model	PRO-CPD20
Can Size	20kg
Weight	≈320kg
Air Pressure	0.4~0.5MPa (Humidity 5% less than, Air Filter 5μ less than)
Power	AC200V~240V, 50/60Hz
Power Consumption	5.2kW
Display	7inch TFT LCD
Operating Method	Touch screen, Button S/W
Operating Mode	AUTO/MANUAL/TEST
Viscosity	1~500,000(cps)
Dosing Pressure	5.0MPa
Displacement	5.0ml/rev
Flux	300ml/min
Accuracy	±1%
Min. Feeding vol	25.0ml/min
Motor Speed	1~150rpm (60rpm Recommended)
Inlet Port	One touch fitting PC (∅8)
Outlet Port	BSPT 3/8, 1/2, 3/4, 1
Material of Stator	FFKM/EPDM
Temperature	0~50°C (Avoid direct sunlight)
Humidity	10~85%RH
Vibration Resistance	Less than 0.5G
Comm. Connector	LAN(Modbus TCP), RS485(Modbus RTU)
Follower Plate	WP(Wiper Plate) / DP(Disposal Plate) / NP(None Plate)

Dimension

