

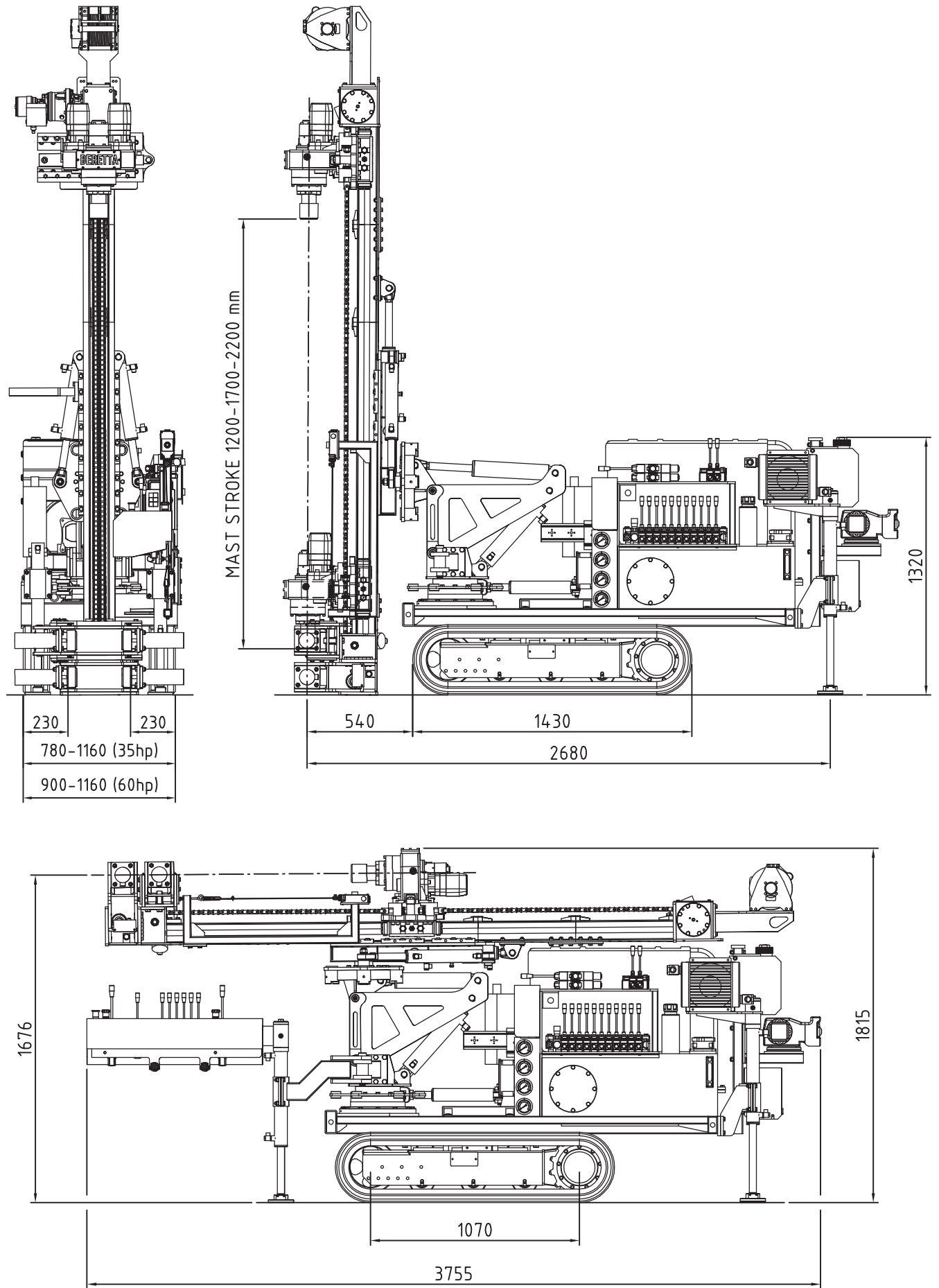

T25 HYDRAULIC DRILLING

CARATTERISTICHE TECNICHE	TECHNICAL DATA		
MOTORE DIESEL SILENZIATO	SILENCED DIESEL ENGINE		
tipo	type	PERKINS 404D-15	
potenza	power	26 KW (35 HP) - 2800 rpm	
OPTIONAL tipo	OPTIONAL type	PERKINS 404D-22T	
potenza	power	44 KW (60 HP) - 2800 rpm	
CARRO CINGOLATO	CRAWLERS		
velocità	speed	0 - 3 km/h	
pendenza massima superabile	max gradeability	55%	
pressione specifica al suolo	ground bearing pressure	4,0 N/cm²	
larghezza pattini	shoe width	235 mm	
carro apertura variabile	opening varying crawlers	800 - 1160 mm	
apertura variabile con diesel da 60HP	varying crawlers with engine of 60HP	900 - 1160 mm	
SLITTA TIPO 1	MAST TYPE 1		
corsa carrello testa rotazione	stroke of rotary head	1200 mm	
tiro-spinta massimo motoriduttore	ratimotor pull-push	30 KN	
tiro-spinta con motore da 60HP	ratimotor pull-push with engine of 60HP	40 KN	
SLITTA TIPO 2	MAST TYPE 2		
corsa carrello testa rotazione	stroke of rotary head	1700 mm	
tiro-spinta massimo motoriduttore	ratimotor pull-push	30 KN	
tiro-spinta con motore da 60HP	ratimotor pull-push with engine of 60HP	40 KN	
TESTA ROTAZIONE "24 2V" STANDARD	"24 2V" STANDARD ROTARY HEAD		
numero marce	speed number	2	
1° marcia - coppia / giri	1st speed - torque / rpm	400 daNm / 50 rpm	
2° marcia - coppia / giri	2nd speed - torque / rpm	200 daNm / 100 rpm	
corsa spostamento laterale	sideways travel stroke	300 mm	
coppia massima con motore da 60HP	max torque with engine of 60HP	500 daNm	
<i>nota: a richiesta si possono avere diverse coppie e numeri di giri - other performances upon request</i>			
MORSA 50-168 mm	50-168 mm CLAMP		
diametri bloccaggio	blocking diameter	50 - 168 mm	
forza di chiusura	clamping force	65 KN	
optional: morsa svitatrice, coppia di svitamento	optional: unscrewing clamp, break-out torque	15 KNm	
ARGANO - OPTIONAL	WINCH - OPTIONAL		
diametro fune	rope diameter	6 mm	
capacità fune	rope capacity	30 m	
tiro massimo	max line pull	400 kg	
ALTRI OPTIONALS	OTHER OPTIONALS		
pompa acqua pulita / clean water pump; pompa schiuma / foam pump; pompa fango a vite / screw mud pump			
pompa cemento / concrete mud pump			
IMPIANTO IDRAULICO	HYDRAULIC SYSTEM	diesel 35HP	diesel 60HP
nr. 4 pompe a ingranaggi standard	no. 4 standard gear pumps		
pompa nr. 1	gear pump no. 1	45 l/min	62 l/min
pompa nr. 2	gear pump no. 2	40 l/min	62 l/min
pompa nr. 3	gear pump no. 3	22 l/min	45 l/min
pompa nr. 4	gear pump no. 4	22 l/min	23 l/min
pressione massima	max pressure	200 BAR	230 BAR
PESO TOTALE MACCHINA	TOTAL WEIGHT MACHINE	2500 kg	2700 kg

Perforatrice Idraulica T25



Perforatrice Idraulica T25

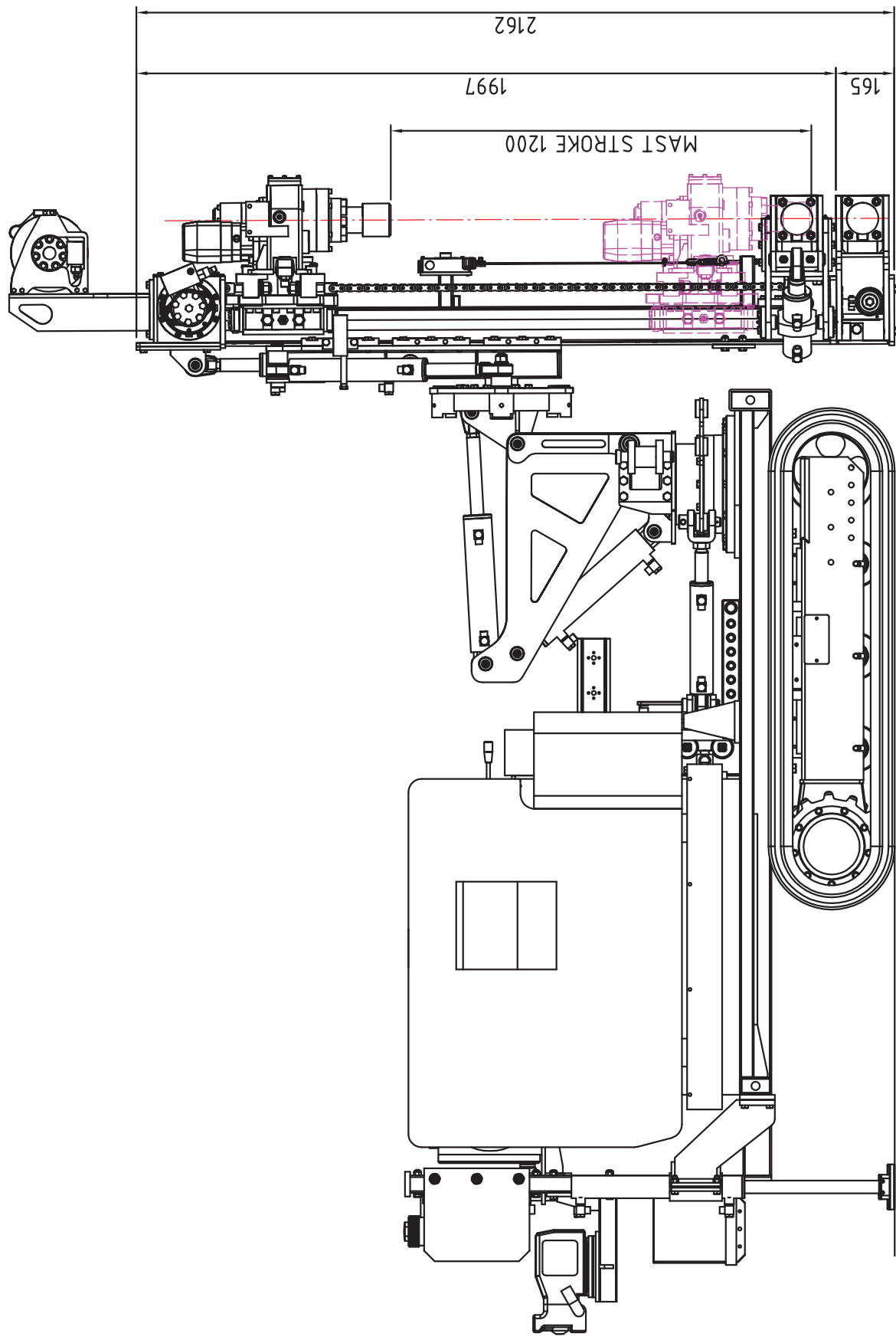

Beretta Alfredo s.r.l. - Via Vignareto, 10 - 20842 Besana Brianza (MB) - Italy
tel. +39-0362-995380 fax. +39-0362-995708 www.berettaalfredo.it

Perforatrice Idraulica T25

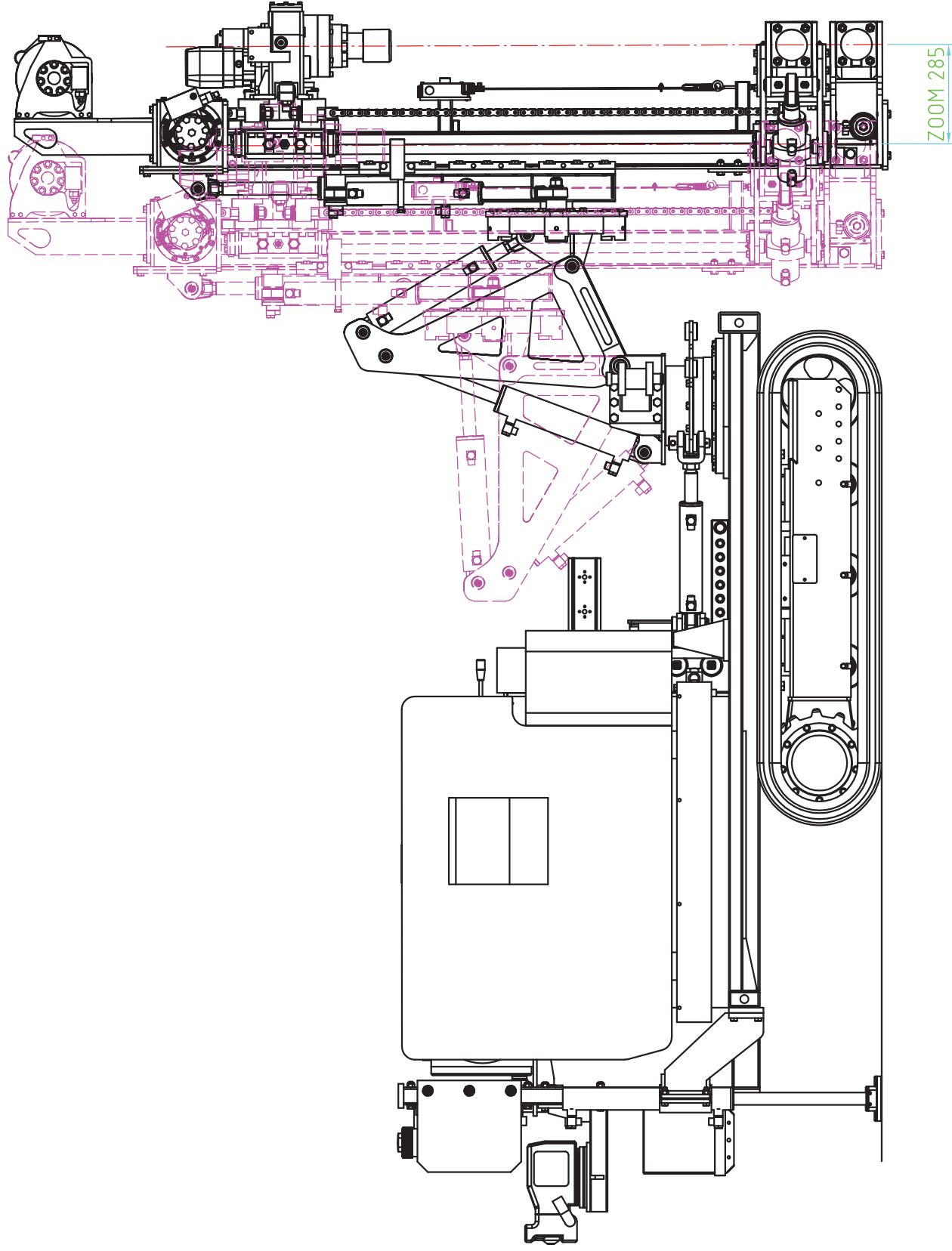

Beretta Alfredo s.r.l. - Via Vignareto, 10 - 20842 Besana Brianza (MB) - Italy
tel. +39-0362-995380 fax. +39-0362-995708 www.berettaalfredo.it

Perforatrice Idraulica T25

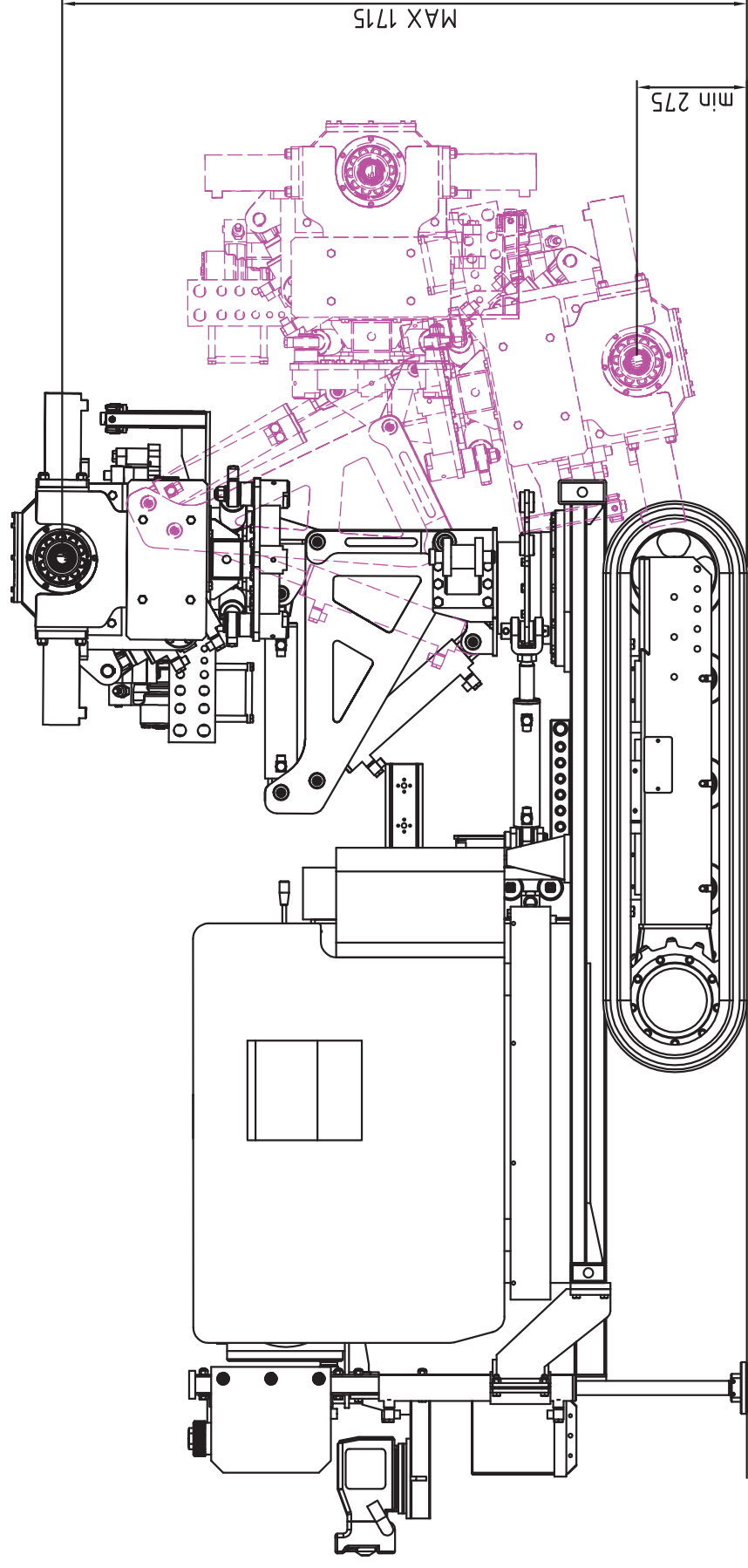

Beretta Alfredo s.r.l. - Via Vignareto, 10 - 20842 Besana Brianza (MB) - Italy
tel. +39-0362-995380 fax. +39-0362-995708 www.berettaalfredo.it

Perforatrice Idraulica T25

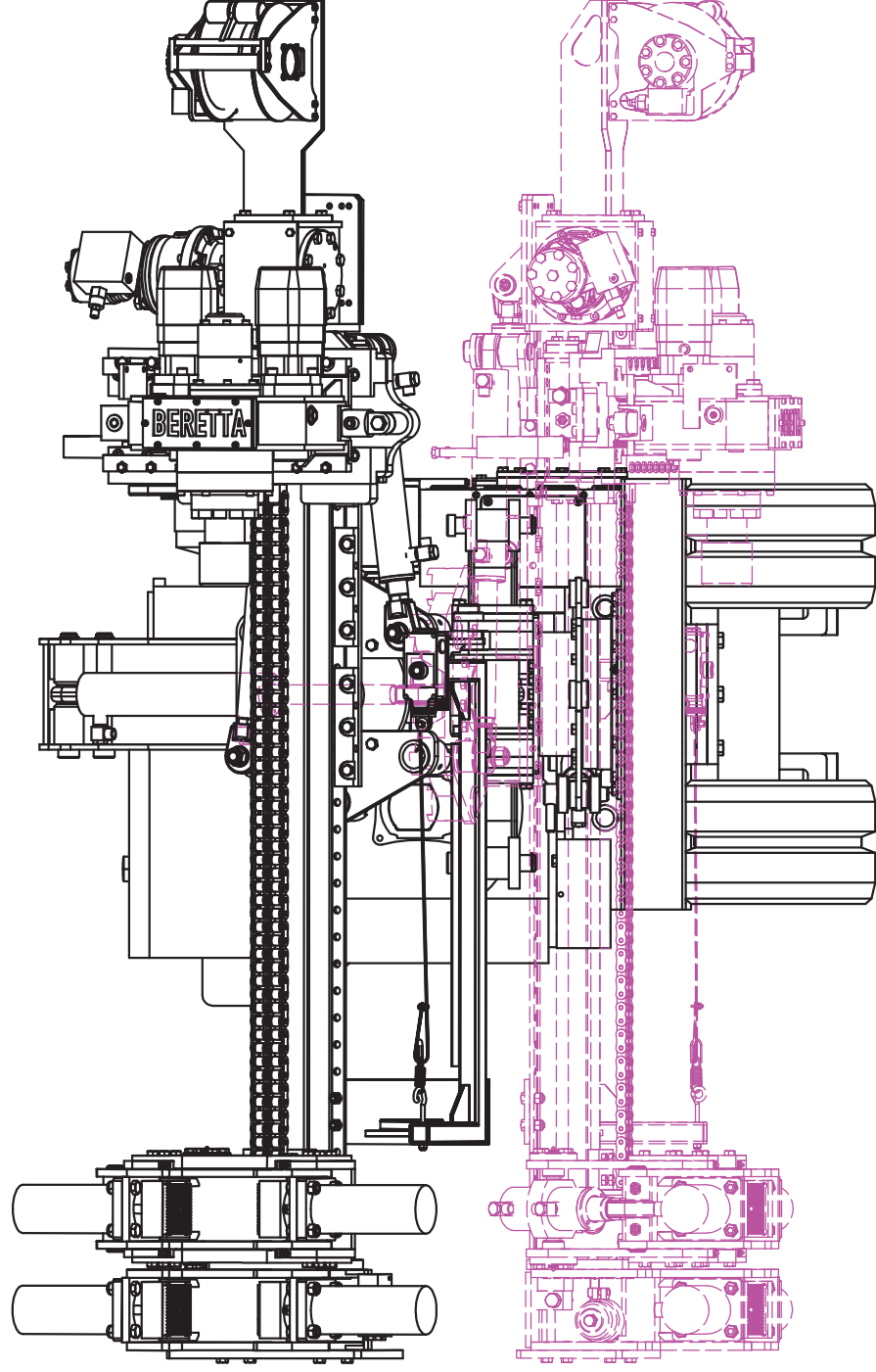

Beretta Alfredo s.r.l. - Via Vignareto, 10 - 20842 Besana Brianza (MB) - Italy
tel. +39-0362-995380 fax. +39-0362-995708 www.berettaalfredo.it

Perforatrice Idraulica T25

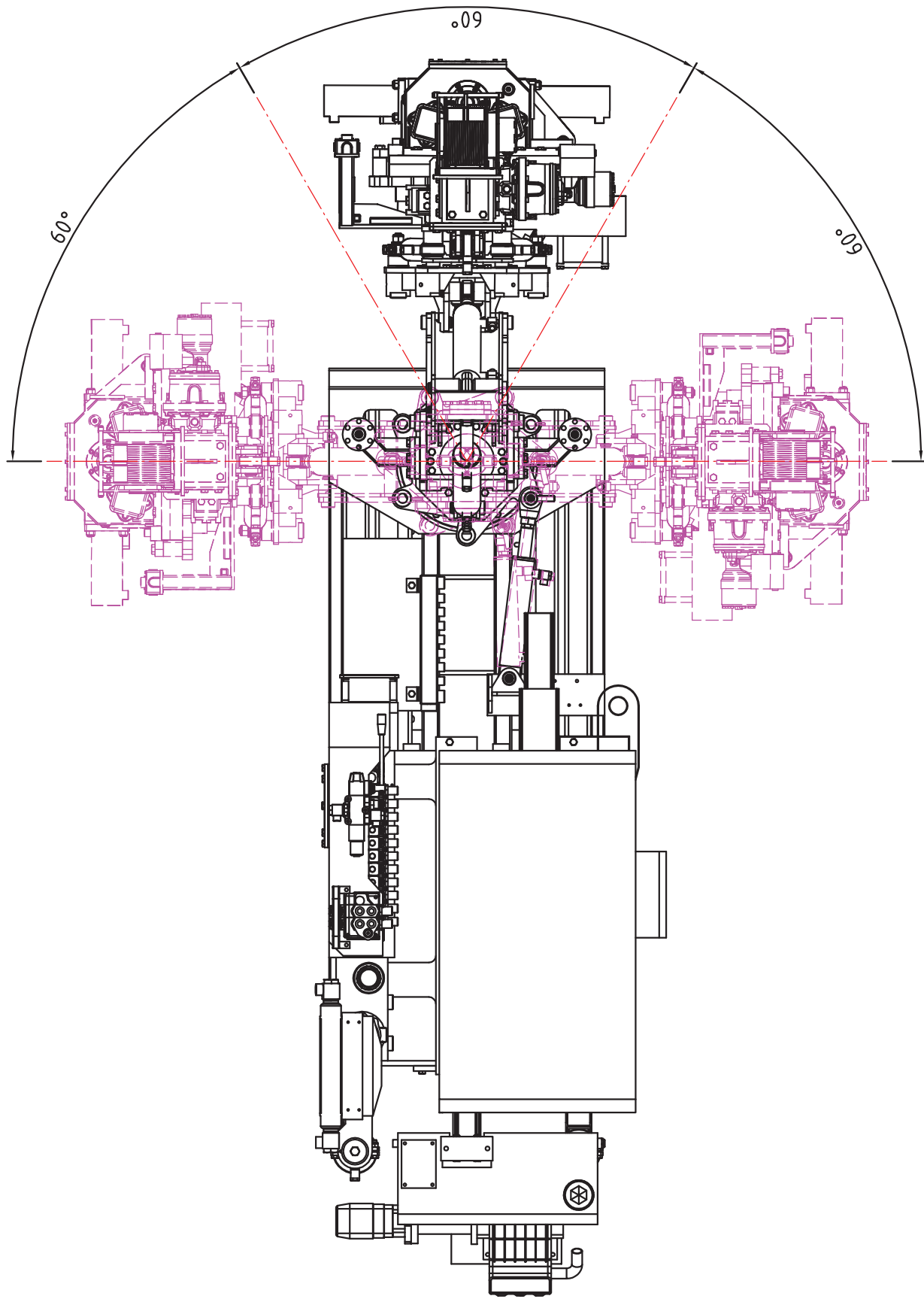

Beretta Alfredo s.r.l. - Via Vignareto, 10 - 20842 Besana Brianza (MB) - Italy
tel. +39-0362-995380 fax. +39-0362-995708 www.berettaalfredo.it

Perforatrice Idraulica T25

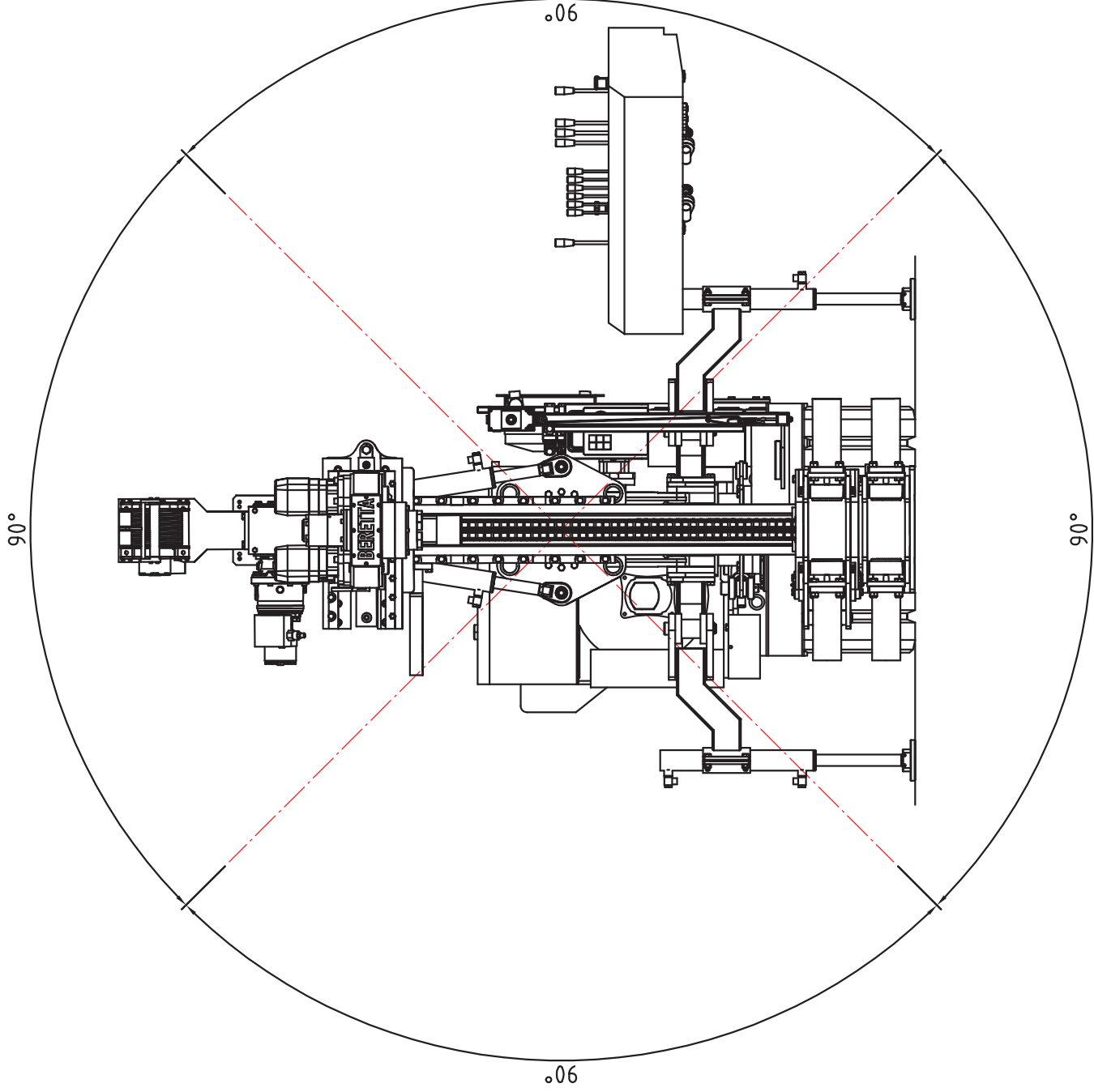

Beretta Alfredo s.r.l. - Via Vignareto, 10 - 20842 Besana Brianza (MB) - Italy
tel. +39-0362-995380 fax. +39-0362-995708 www.berettaalfredo.it

Perforatrice Idraulica T25

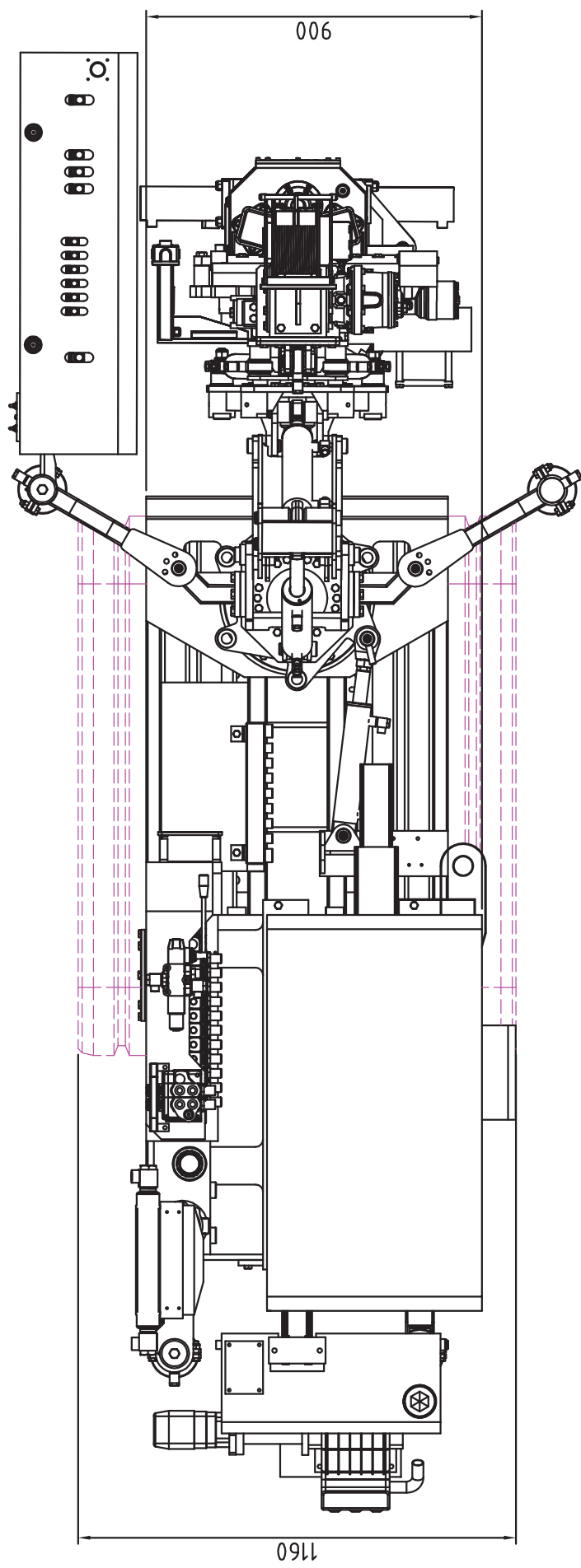

Beretta Alfredo s.r.l. - Via Vignareto, 10 - 20842 Besana Brianza (MB) - Italy
tel. +39-0362-995380 fax. +39-0362-995708 www.berettaalfredo.it