

K 8/25
K10/25
K13/25

Caractéristiques Technical data	K 8/25	K 10/25	K 13/25
Chambre de broyage (mm) Shredding chamber (mm)	758x700	1008x700	1258x700
Lames de 30 mm (u) 30 mm blades (no.)	25	33	41
Lames de 50 mm (u) 50 mm blades (no.)	15	20	25
Puissance électrique (kW) Power (kW)	18,5	18,5	18,5
Tension (V) Voltage (V)	220/400/460	220/400/460	220/400/460
Poids (kg) Weight (kg)	2500	2810	3145

Les pièces de broyage petites et uniformes sont disponibles en version "CL", système de contre-lames.
For small and uniform material shred size available version with "CL" Counter Blades System

Documentation Technique / Technical Data

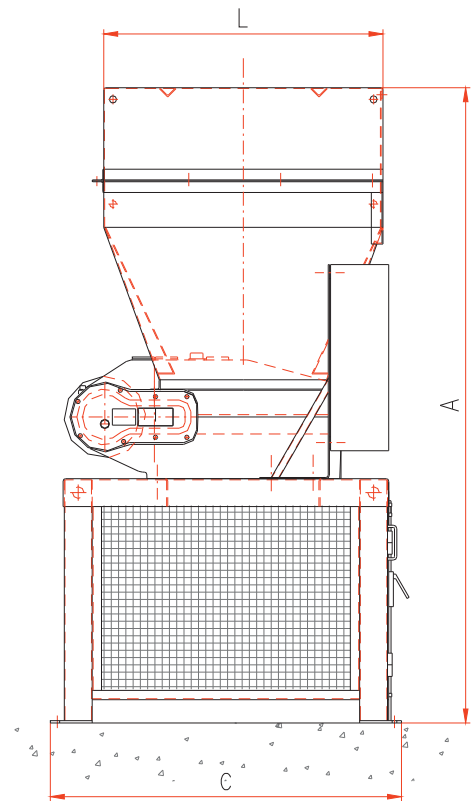
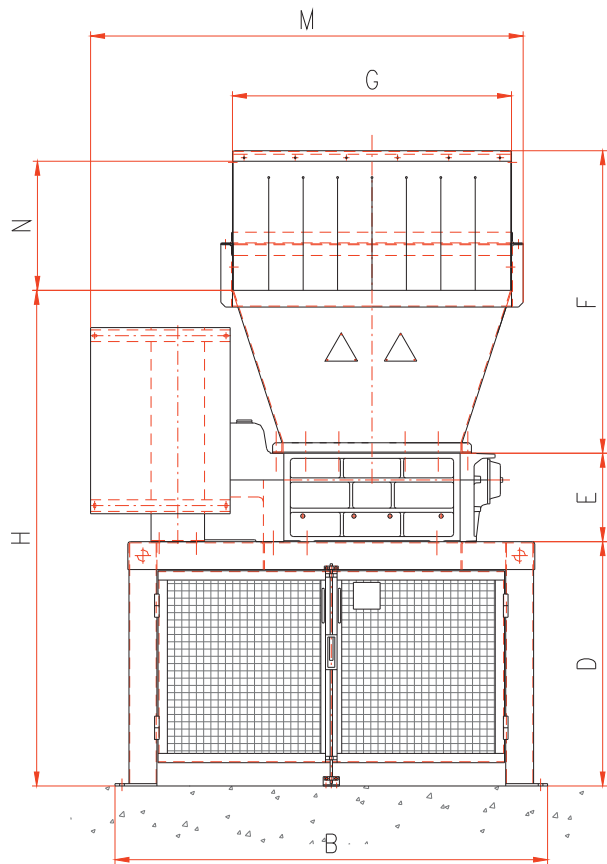



Déchets traités / Some applications:

- 
 Plastics
 Plastiques

0,4÷0,8 t/h
- 
 Pallets
 Palettes

40÷60 pcs/h
- 
 Waste from catering
 Déchets alimentaires

0,8÷1,5 t/h
- 
 Plastic drums (200/220 l)
 Fûts en plastique (200/220 l)

60÷90 pcs/h
- 
 Industrial scraps
 Déchets industriels

0,6÷1,2 t/h
- 
 Car tyres
 Pneus véhicules légers

60÷150 pcs/h

	K8/25	K10/25	K13/25
A	2730	2730	2730
B	1860	1860	2110
C	1510	1510	1510
D	1050	1050	1050
E	380	380	380
F	1300	1300	1300
G	1200	1450	1700
H	2130	2130	2130
L	1200	1200	1200
M	1860	2085	2335
N	555	555	555

CAT1008 Rev. A.04/15

SatrindTech S.r.l.
 Via Monfalcone, 122 - 20010, Arluno (MI) - Italie
 Tel. (+39) 02 90 37 66 83

sales@satrindtech.com
 satrindtech.com

SatrindTech France - Groupe SEREX
 19, chemin de la Violette, 31240 L'Union - France
 Tel. (+33) 05 62 89 08 88

contact@satrindtech-france.fr
 www.satrindtech-france.fr

