

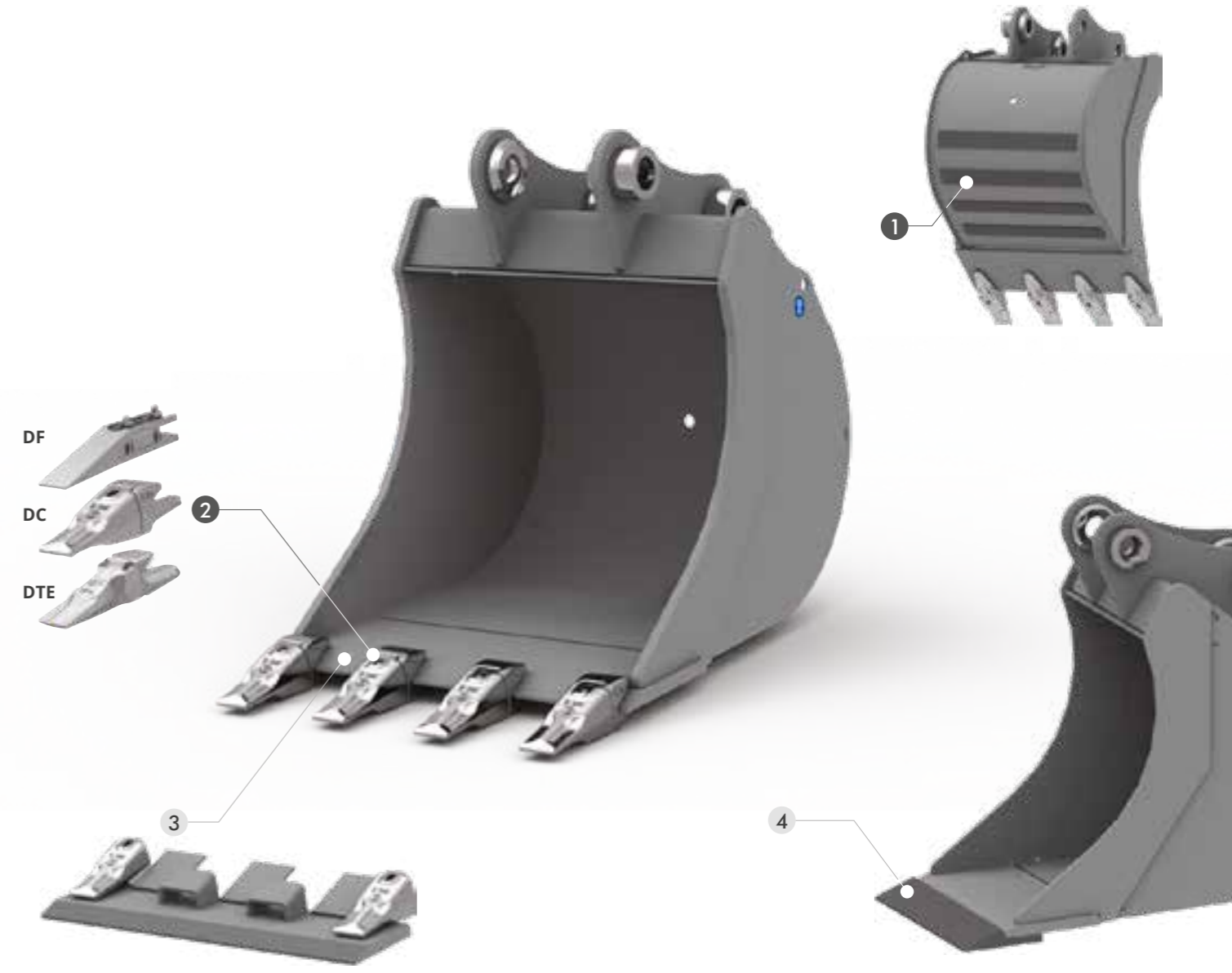

ITS SHAPE HAS BEEN CONCEIVED TO HELP THE TOOL TO PENETRATE MEDIUM-CONSISTENCY SOILS.



STANDARD TECHNICAL FEATURES

- 1 REINFORCING STRIPS**
THE HORIZONTAL REINFORCING STRIPS ON THE BUCKET'S REAR AND BOTTOM PROTECT THE BUCKET FROM WEAR AND INCREASE ITS RESISTANCE.
- 2 DF TEETH DC TEETH DTE TEETH**

OPTIONAL

- 3 GRADING EDGE**
INSTALLED DIRECTLY ON THE ADAPTERS OF THE WELDED TEETH. THIS PATTERN MAKES THE INSTALLING/UNINSTALLING OPERATIONS EASIER AND GRANTS A HIGH RESISTANCE TO THE BUCKET.
- 4 HB500 WELDED ADDITIONAL CUTTING EDGE (NO TEETH)**
RECOMMENDED TO WORK ON PARTICULARLY ABRASIVE SOILS.

MOD.	MIDI EXCAVATOR										SC85	SC92 GD	SC100GD	SC110GD
	SC27	SC36	SC38	SC45	SC53	SC62	SC67	SC73	SC80	SC85				
TONS (LB)	0,6 - 1,2 (1323 - 2646)	1,2 - 1,8 (2646 - 3968)	1,2 - 1,8 (2646 - 3968)	1,8 - 2,5 (3968 - 5512)	2,5 - 4,0 (5512 - 8818)	4,0 - 5,0 (8818 - 11023)	5,0 - 7,5 (11023 - 16535)	7,5 - 10,0 (16535 - 22046)	10,0 - 12,0 (22046 - 26455)	12,0 - 14,0 (26455 - 30865)	12,0 - 14,0 (26455 - 30865)	14,0 - 18,0 (30865 - 39683)	18,0 - 22,0 (39683 - 48502)	

SC27 MACHINE WEIGHT 0,6 - 1,2 t (1323 - 2646 lb)

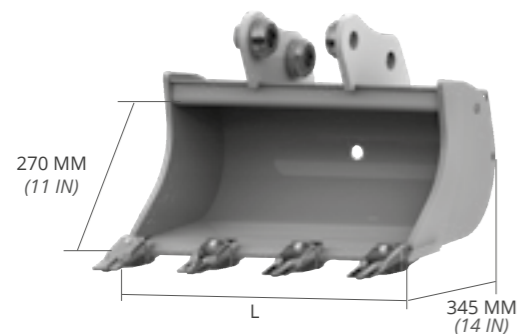

L MM (IN)	WEIGHT KG* (LB*)	CAP. SAE L (GAL)	TEETH N°	ADAPTERS
200 (8)	11 (24)	10 (2,6)	2	AF S - CM CW
250 (10)	13 (29)	14 (3,7)	DF2 DC3 DE3	AF S - CM CW
300 (12)	15 (33)	18 (4,8)	3	AF S - CM CW
350 (14)	17 (37)	21 (5,5)	3	AF S - CM CW
400 (16)	18 (40)	25 (6,6)	3	AF S - CM CW
450 (18)	20 (44)	30 (7,9)	3	AF S - CM CW
500 (20)	22 (49)	34 (9,0)	4	AF S - CM CW
600 (24)	26 (57)	42 (11,1)	4	AF S - CM CW
700 (28)	30 (66)	50 (13,2)	5	AF S - CM CW

* weight of the tank excluding attachment

SC27 QUICK COUPLER MACHINE WEIGHT 0,6 - 1,2 t (1323 - 2646 lb)

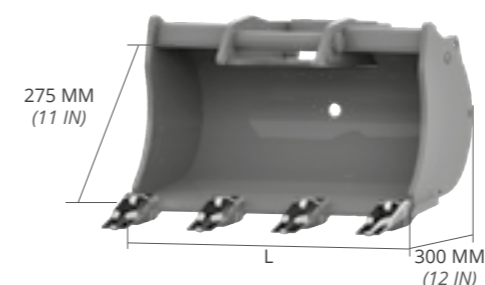
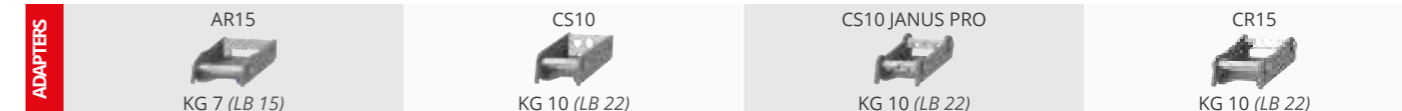

L MM (IN)	WEIGHT KG* (LB*)	CAP. SAE L (GAL)	TEETH N°	ADAPTERS
200 (8)	11 (24)	10 (2,6)	2	AR - CS CR CS JANUS PRO
250 (10)	13 (29)	14 (3,7)	DF2 DC3 DE3	AR - CS CR CS JANUS PRO
300 (12)	15 (33)	18 (4,8)	3	AR - CS CR CS JANUS PRO
350 (14)	17 (37)	21 (5,5)	3	AR - CS CR CS JANUS PRO
400 (16)	18 (40)	25 (6,6)	3	AR - CS CR CS JANUS PRO
450 (18)	20 (44)	30 (7,9)	3	AR - CS CR CS JANUS PRO
500 (20)	22 (49)	34 (9,0)	4	AR - CS CR CS JANUS PRO
600 (24)	26 (57)	42 (11,1)	4	AR - CS CR CS JANUS PRO
700 (28)	30 (66)	50 (13,2)	5	AR - CS CR CS JANUS PRO

* weight of the tank excluding attachment

OPTIONAL

3	4
SUPPLEMENTARY BLADE	HB500 WELDED ADDITIONAL CUTTING EDGE

OPTIONAL

3	4
SUPPLEMENTARY BLADE	HB500 WELDED ADDITIONAL CUTTING EDGE

SC36 MACHINE WEIGHT 1,2 - 1,8 t (2646 - 3968 lb)

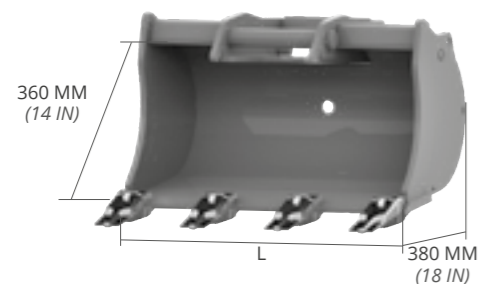
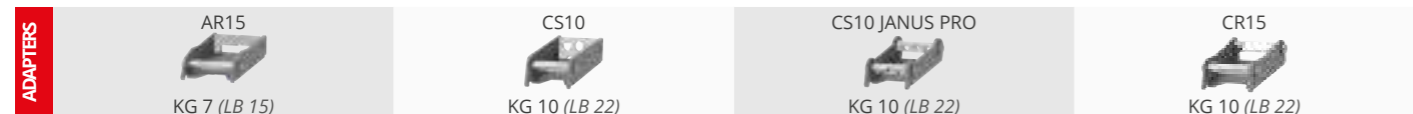

L MM (IN)	WEIGHT KG* (LB*)	CAP. SAE L (GAL)	TEETH N.	ADAPTERS
200 (8)	15 (33)	15 (4,0)	2	AR - CS CR CS JANUS PRO
250 (10)	17 (37)	20 (5,3)	DF2 DC3 DE3	AR - CS CR CS JANUS PRO
300 (12)	19 (42)	25 (6,6)	3	AR - CS CR CS JANUS PRO
350 (14)	21 (46)	31 (8,2)	3	AR - CS CR CS JANUS PRO
400 (16)	24 (53)	37 (9,8)	3	AR - CS CR CS JANUS PRO
450 (18)	27 (60)	43 (11,4)	3	AR - CS CR CS JANUS PRO
500 (20)	30 (66)	49 (12,4)	4	AR - CS CR CS JANUS PRO
600 (24)	34 (75)	61 (16,1)	4	AR - CS CR CS JANUS PRO
700 (28)	39 (86)	74 (19,5)	5	AR - CS CR CS JANUS PRO

* weight of the tank excluding attachment

SC38 MACHINE WEIGHT 1,2 - 1,8 t (2646 - 3968 lb)

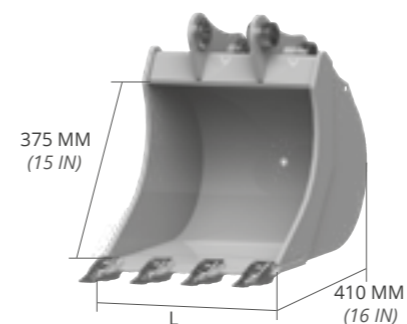
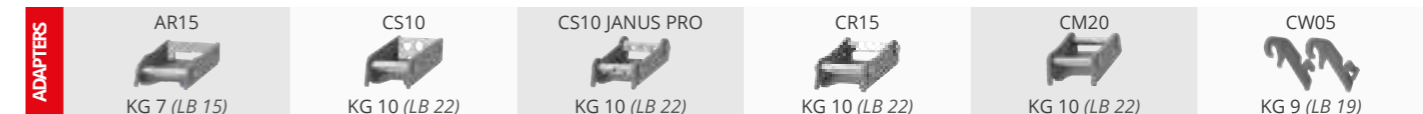

L MM (IN)	WEIGHT KG* (LB*)	CAP. SAE L (GAL)	TEETH N.	ADAPTERS
200 (8)	15 (33)	15 (4,0)	2	AF - AR - CS CR - CM CW - CS JANUS PRO
250 (10)	17 (37)	20 (5,3)	DF2 DC3 DE3	AF - AR - CS CR - CM CW - CS JANUS PRO
300 (12)	19 (42)	25 (6,6)	3	AF - AR - CS CR - CM CW - CS JANUS PRO
350 (14)	21 (46)	31 (8,2)	3	AF - AR - CS CR - CM CW - CS JANUS PRO
400 (16)	24 (53)	37 (9,8)	3	AF - AR - CS CR - CM CW - CS JANUS PRO
450 (18)	27 (60)	43 (11,4)	3	AF - AR - CS CR - CM CW - CS JANUS PRO
500 (20)	30 (66)	49 (12,4)	4	AF - AR - CS CR - CM CW - CS JANUS PRO
600 (24)	34 (75)	61 (16,1)	4	AF - AR - CS CR - CM CW - CS JANUS PRO
700 (28)	39 (86)	74 (19,5)	5	AF - AR - CS CR - CM CW - CS JANUS PRO

* weight of the tank excluding attachment

OPTIONAL

- 3 SUPPLEMENTARY BLADE
- 4 HB500 WELDED ADDITIONAL CUTTING EDGE

OPTIONAL

- 3 SUPPLEMENTARY BLADE
- 4 HB500 WELDED ADDITIONAL CUTTING EDGE

SC45 MACHINE WEIGHT 1,8 - 2,5 t (3968 - 5512 lb)

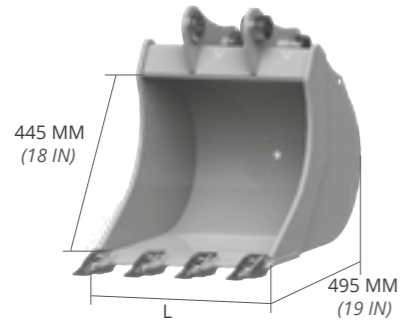

L WEIGHT CAP. SAE TEETH
MM KG* L N.
(IN) (LB*) (GAL)

ADAPTERS

L MM (IN)	WEIGHT KG* (LB*)	CAP. L (GAL)	SAE L	TEETH N.	ADAPTERS
250 (10)	23 (51)	25 (6,6)		2	AF - AR - CS CR - CM CW - CS JANUS PRO
300 (12)	26 (57)	33 (8,7)		3	AF - AR - CS CR - CM CW - CS JANUS PRO
350 (14)	29 (64)	40 (10,6)		3	AF - AR - CS CR - CM CW - CS JANUS PRO
400 (16)	32 (71)	48 (12,7)		3	AF - AR - CS CR - CM CW - CS JANUS PRO
450 (18)	35 (77)	56 (14,8)		3	AF - AR - CS CR - CM CW - CS JANUS PRO
500 (20)	38 (84)	65 (17,2)		4	AF - AR - CS CR - CM CW - CS JANUS PRO
600 (24)	44 (97)	82 (21,7)		4	AF - AR - CS CR - CM CW - CS JANUS PRO
700 (28)	50 (110)	100 (26,4)		5	AF - AR - CS CR - CM CW - CS JANUS PRO
800 (31)	58 (128)	117 (30,9)		5	AF - AR - CS CR - CM CW - CS JANUS PRO

* weight of the tank excluding attachment

SC53 MACHINE WEIGHT 2,5 - 4,0 t (5512 - 8818 lb)

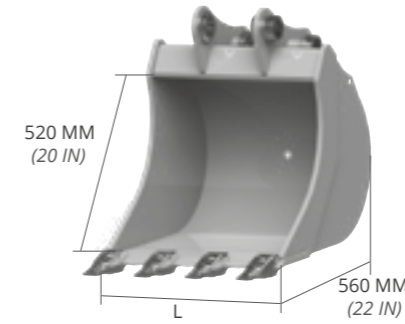
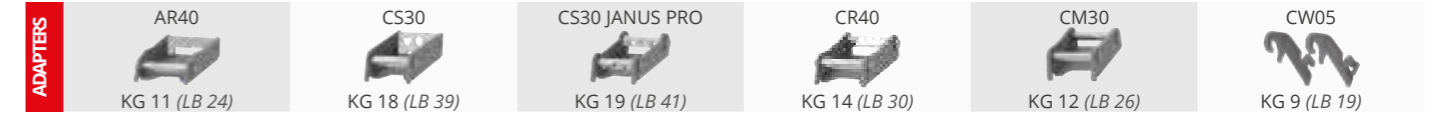

L WEIGHT CAP. SAE TEETH
MM KG* L N.
(IN) (LB*) (GAL)

ADAPTERS

L MM (IN)	WEIGHT KG* (LB*)	CAP. L (GAL)	SAE L	TEETH N.	ADAPTERS
250 (10)	32 (71)	32 (8,5)		2	AF - AR - CS CR - CM CW - CS JANUS PRO
300 (12)	35 (77)	41 (10,8)		3	AF - AR - CS CR - CM CW - CS JANUS PRO
350 (14)	40 (88)	51 (13,5)		3	AF - AR - CS CR - CM CW - CS JANUS PRO
400 (16)	44 (97)	61 (16,1)		3	AF - AR - CS CR - CM CW - CS JANUS PRO
450 (18)	48 (106)	72 (19,0)		3	AF - AR - CS CR - CM CW - CS JANUS PRO
500 (20)	51 (112)	82 (21,7)		4	AF - AR - CS CR - CM CW - CS JANUS PRO
600 (24)	59 (130)	105 (27,7)		4	AF - AR - CS CR - CM CW - CS JANUS PRO
700 (28)	67 (148)	127 (33,5)		5	AF - AR - CS CR - CM CW - CS JANUS PRO
800 (31)	75 (165)	152 (40,2)		5	AF - AR - CS CR - CM CW - CS JANUS PRO
900 (35)	83 (183)	175 (46,2)		5	AF - AR - CS CR - CM CW - CS JANUS PRO

* weight of the tank excluding attachment

OPTIONAL

- 3 SUPPLEMENTARY BLADE
- 4 HB500 WELDED ADDITIONAL CUTTING EDGE

OPTIONAL

- 3 SUPPLEMENTARY BLADE
- 4 HB500 WELDED ADDITIONAL CUTTING EDGE

SC62 MACHINE WEIGHT 4,0 - 5,0 t (8818 - 11023 lb)

ADAPTERS	AR50	CS30	CS30 JANUS PRO	CR50	CM100	CW10
	KG 17 (LB 37)	KG 18 (LB 39)	KG 19 (LB 41)	KG 22 (LB 48)	KG 35 (LB 77)	KG 23 (LB 50)

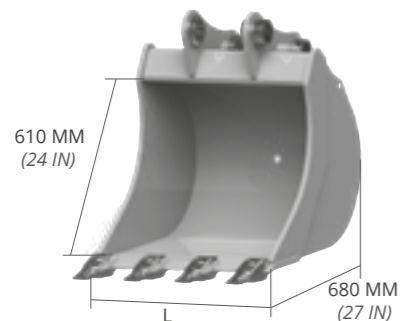

L MM (IN)	WEIGHT KG* (LB*)	CAP. SAE L (GAL)	TEETH N.	ADAPTERS
250 (10)	48 (106)	45 (11,9)	2	AF - AR - CS CR - CM CW - CS JANUS PRO
300 (12)	53 (117)	58 (15,3)	3	AF - AR - CS CR - CM CW - CS JANUS PRO
350 (14)	58 (128)	71 (18,8)	3	AF - AR - CS CR - CM CW - CS JANUS PRO
400 (16)	63 (139)	85 (22,5)	3	AF - AR - CS CR - CM CW - CS JANUS PRO
450 (18)	68 (150)	100 (26,4)	3	AF - AR - CS CR - CM CW - CS JANUS PRO
500 (20)	73 (161)	115 (30,4)	4	AF - AR - CS CR - CM CW - CS JANUS PRO
600 (24)	84 (185)	147 (38,8)	4	AF - AR - CS CR - CM CW - CS JANUS PRO
700 (28)	95 (209)	180 (47,6)	5	AF - AR - CS CR - CM CW - CS JANUS PRO
800 (31)	106 (234)	213 (56,3)	5	AF - AR - CS CR - CM CW - CS JANUS PRO
900 (35)	117 (258)	248 (65,5)	6	AF - AR - CS CR - CM CW - CS JANUS PRO
1000 (39)	128 (282)	282 (74,5)	6	AF - AR - CS CR - CM CW - CS JANUS PRO

* weight of the tank excluding attachment

SC67 MACHINE WEIGHT 5,0 - 7,5 t (11023 - 16535 lb)

ADAPTERS	AR50	AR70	CS80	CS80 JANUS PRO	CR50	CR70	CM100	CW10
	KG 17 (LB 37)	KG 24 (LB 52)	KG 44 (LB 97)	KG 46 (LB 101)	KG 22 (LB 48)	KG 34 (LB 75)	KG 35 (LB 77)	KG 23 (LB 50)

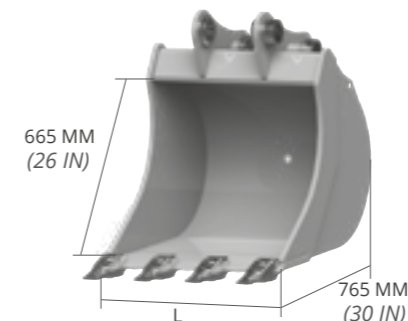

L MM (IN)	WEIGHT KG* (LB*)	CAP. SAE L (GAL)	TEETH N.	ADAPTERS
300 (12)	70 (154)	68 (18,0)	3	AF - AR - CS CR - CM CW - CS JANUS PRO
350 (14)	78 (172)	84 (22,2)	3	AF - AR - CS CR - CM CW - CS JANUS PRO
400 (16)	85 (187)	101 (26,7)	3	AF - AR - CS CR - CM CW - CS JANUS PRO
450 (18)	92 (203)	118 (31,2)	3	AF - AR - CS CR - CM CW - CS JANUS PRO
500 (20)	99 (218)	137 (36,2)	4	AF - AR - CS CR - CM CW - CS JANUS PRO
600 (24)	114 (251)	174 (46,0)	4	AF - AR - CS CR - CM CW - CS JANUS PRO
700 (28)	128 (282)	214 (56,5)	5	AF - AR - CS CR - CM CW - CS JANUS PRO
800 (31)	142 (313)	254 (67,1)	5	AF - AR - CS CR - CM CW - CS JANUS PRO
900 (35)	156 (344)	295 (77,9)	6	AF - AR - CS CR - CM CW - CS JANUS PRO
1000 (39)	170 (375)	338 (89,3)	6	AF - AR - CS CR - CM CW - CS JANUS PRO

* weight of the tank excluding attachment

OPTIONAL

3	4
SUPPLEMENTARY BLADE	HB500 WELDED ADDITIONAL CUTTING EDGE

OPTIONAL

3	4
SUPPLEMENTARY BLADE	HB500 WELDED ADDITIONAL CUTTING EDGE

SC73 MACHINE WEIGHT 7,5 - 10,0 t (116535 - 22046 lb)

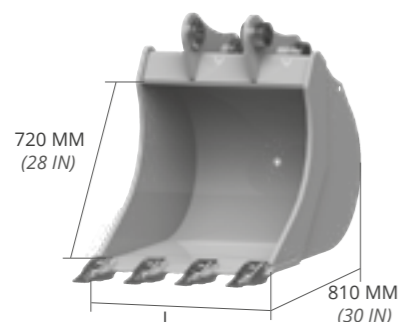

L MM (IN)	WEIGHT KG* (LB*)	CAP. SAE L (GAL)	TEETH N.	ADAPTERS
300 (12)	82 (181)	76 (20,1)	2	AF - CS
				CR - CM
				CW - CS JANUS PRO
350 (14)	89 (196)	94 (24,8)	3	AF - CS
				CR - CM
				CW - CS JANUS PRO
400 (16)	94 (207)	113 (29,9)	3	AF - CS
				CR - CM
				CW - CS JANUS PRO
450 (18)	103 (227)	133 (35,1)	3	AF - CS
				CR - CM
				CW - CS JANUS PRO
500 (20)	111 (245)	153 (40,4)	3	AF - CS
				CR - CM
				CW - CS JANUS PRO
600 (24)	127 (280)	196 (51,8)	4	AF - CS
				CR - CM
				CW - CS JANUS PRO
700 (28)	143 (315)	240 (63,4)	4	AF - CS
				CR - CM
				CW - CS JANUS PRO
800 (31)	159 (351)	286 (75,6)	5	AF - CS
				CR - CM
				CW - CS JANUS PRO
900 (35)	175 (386)	333 (88,0)	5	AF - CS
				CR - CM
				CW - CS JANUS PRO
1000 (39)	191 (421)	379 (100,1)	5	AF - CS
				CR - CM
				CW - CS JANUS PRO
1100 (43)	207 (456)	430 (113,6)	5	AF - CS
				CR - CM
				CW - CS JANUS PRO

* weight of the tank excluding attachment

SC80 MACHINE WEIGHT 10,0 - 12,0 t (22046 - 26455 lb)

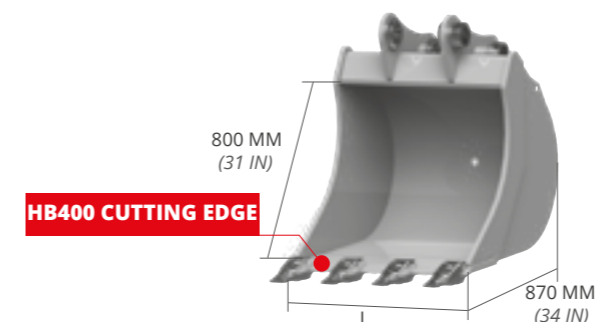

OPTIONAL

L MM (IN)	WEIGHT KG* (LB*)	CAP. SAE L (GAL)	TEETH N.	ADAPTERS
300 (12)	102 (225)	86 (22,7)	2	AF - CS
				CR - CM - CS JANUS PRO
				CW
350 (14)	110 (243)	107 (28,3)	3	AF - CS
				CR - CM - CS JANUS PRO
				CW
400 (16)	121 (267)	129 (34,1)	3	AF - CS
				CR - CM - CS JANUS PRO
				CW
450 (18)	130 (287)	151 (39,9)	3	AF - CS
				CR - CM - CS JANUS PRO
				CW
500 (20)	139 (306)	174 (46,0)	3	AF - CS
				CR - CM - CS JANUS PRO
				CW
600 (24)	157 (346)	222 (58,6)	4	AF - CS
				CR - CM - CS JANUS PRO
				CW
700 (28)	175 (386)	273 (72,1)	4	AF - CS
				CR - CM - CS JANUS PRO
				CW
800 (31)	191 (421)	325 (85,9)	5	AF - CS
				CR - CM - CS JANUS PRO
				CW
900 (35)	209 (461)	379 (100,1)	5	AF - CS
				CR - CM - CS JANUS PRO
				CW
1000 (39)	226 (498)	433 (114,4)	5	AF - CS
				CR - CM - CS JANUS PRO
				CW
1100 (43)	244 (538)	486 (128,4)	5	AF - CS
				CR - CM - CS JANUS PRO
				CW
1200 (47)	262 (578)	546 (144,2)	6	AF - CS
				CR - CM - CS JANUS PRO
				CW
1300 (51)	280 (617)	602 (159,0)	6	AF - CS
				CR - CM - CS JANUS PRO
				CW

* weight of the tank excluding attachment

OPTIONAL

3	4
SUPPLEMENTARY BLADE	HB500 WELDED ADDITIONAL CUTTING EDGE

OPTIONAL

3	4
SUPPLEMENTARY BLADE	HB500 WELDED ADDITIONAL CUTTING EDGE

SC85 MIDI MACHINE WEIGHT 12,0 - 14,0 t (26455 - 30865 lb)

ADAPTERS	CS100 KG 45 (LB 99)	CS100 JANUS PRO KG 93 (LB 205)	CM180 KG 66 (LB 145)	CW20 KG 57 (LB 126)
----------	------------------------	-----------------------------------	-------------------------	------------------------

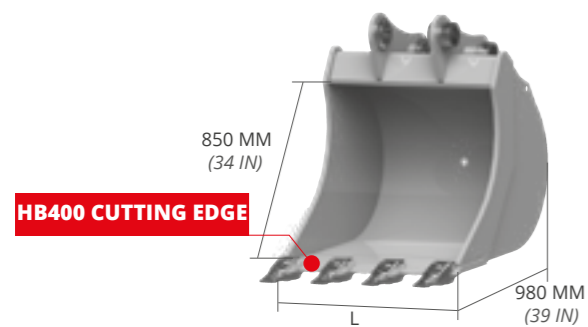

L MM (IN)	WEIGHT KG* (LB*)	CAP. SAE L (GAL)	TEETH N.	ADAPTERS
400 (16)	170 (375)	171 (45,2)	3	AF - CM
				CS - CW
				CS JANUS PRO
500 (20)	190 (419)	235 (62,1)	3	AF - CM
				CS - CW
				CS JANUS PRO
600 (24)	210 (463)	300 (79,3)	4	AF - CM
				CS - CW
				CS JANUS PRO
700 (28)	230 (507)	368 (97,2)	4	AF - CM
				CS - CW
				CS JANUS PRO
800 (31)	250 (551)	438 (115,7)	5	AF - CM
				CS - CW
				CS JANUS PRO
900 (35)	270 (595)	510 (134,7)	5	AF - CM
				CS - CW
				CS JANUS PRO
1000 (39)	291 (642)	584 (154,3)	5	AF - CM
				CS - CW
				CS JANUS PRO
1100 (43)	312 (688)	657 (173,6)	5	AF - CM
				CS - CW
				CS JANUS PRO
1200 (47)	333 (734)	730 (192,8)	6	AF - CM
				CS - CW
				CS JANUS PRO
1300 (51)	354 (780)	810 (214,0)	6	AF - CM
				CS - CW
				CS JANUS PRO

* weight of the tank excluding attachment

SC92 GD EXCAVATOR MACHINE WEIGHT 12,0 - 14,0 t (26455 - 30865 lb)

ADAPTERS	CS100 KG 45 (LB 99)	CS100 JANUS PRO KG 93 (LB 205)	CM180 KG 66 (LB 145)	CW20 KG 54 (LB 126)
----------	------------------------	-----------------------------------	-------------------------	------------------------

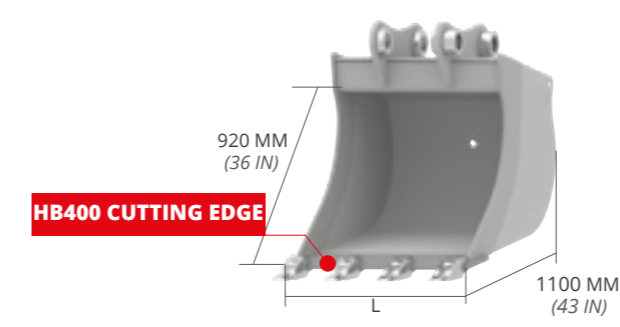

L MM (IN)	WEIGHT KG* (LB*)	CAP. SAE L (GAL)	TEETH N.	ADAPTERS
400 (16)	185 (407)	250 (66)	3	AF - CM
				CS - CW
				CS JANUS PRO
500 (20)	213 (469)	315 (83)	3	AF - CM
				CS - CW
				CS JANUS PRO
600 (24)	228 (503)	380 (100,4)	4	AF - CM
				CS - CW
				CS JANUS PRO
700 (28)	251 (553)	450 (118,9)	4	AF - CM
				CS - CW
				CS JANUS PRO
800 (31)	281 (619)	560 (147,9)	5	AF - CM
				CS - CW
				CS JANUS PRO
900 (35)	309 (681)	620 (163,8)	5	AF - CM
				CS - CW
				CS JANUS PRO
1000 (39)	350 (772)	700 (184,9)	5	AF - CM
				CS - CW
				CS JANUS PRO
1200 (47)	403 (888)	900 (237,7)	6	AF - CM
				CS - CW
				CS JANUS PRO

* weight of the tank excluding attachment

OPTIONAL

3	4
SUPPLEMENTARY BLADE	HB500 WELDED ADDITIONAL CUTTING EDGE

OPTIONAL

3	4
SUPPLEMENTARY BLADE	HB500 WELDED ADDITIONAL CUTTING EDGE

SC100 GD MACHINE WEIGHT 14,0 - 18,0 t (30865 - 39683 lb)

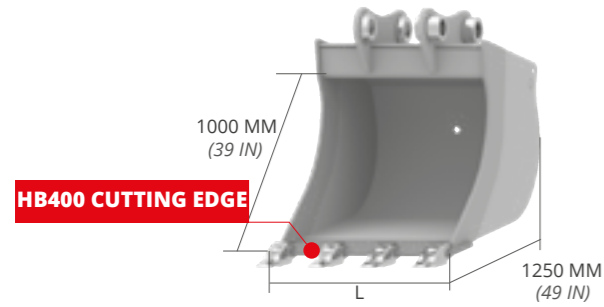

L MM (IN)	WEIGHT KG* (LB*)	CAP. SAE L (GAL)	TEETH N.	ADAPTERS
400 (16)	250 (511)	300 (79)	3	AF - CM
				CS - CW
				CS JANUS PRO
500 (20)	287 (632)	370 (98)	3	AF - CM
				CS - CW
				CS JANUS PRO
600 (24)	316 (697)	450 (118,9)	3	AF - CM
				CS - CW
				CS JANUS PRO
700 (28)	355 (783)	535 (141,3)	4	AF - CM
				CS - CW
				CS JANUS PRO
800 (31)	394 (869)	620 (163,7)	4	AF - CM
				CS - CW
				CS JANUS PRO
900 (35)	433 (955)	710 (187,5)	4	AF - CM
				CS - CW
				CS JANUS PRO
1000 (39)	472 (1041)	800 (211,3)	5	AF - CM
				CS - CW
				CS JANUS PRO
1200 (47)	550 (1213)	980 (258,8)	5	AF - CM
				CS - CW
				CS JANUS PRO

* weight of the tank excluding attachment

SC110 GD MACHINE WEIGHT 18,0 - 22,0 t (39683 - 48502 lb)

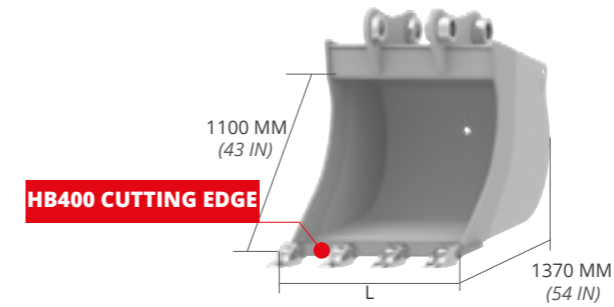

L MM (IN)	WEIGHT KG* (LB*)	CAP. SAE L (GAL)	TEETH N.	ADAPTERS
600 (24)	412 (908)	480 (126,8)	3	AF - CM
				CS - CW
				CS JANUS PRO
800 (31)	502 (1107)	690 (182,3)	4	AF - CM
				CS - CW
				CS JANUS PRO
1000 (39)	592 (1305)	900 (237,7)	5	AF - CM
				CS - CW
				CS JANUS PRO
1200 (47)	682 (1504)	1110 (293,2)	5	AF - CM
				CS - CW
				CS JANUS PRO
1300 (52)	727 (1603)	1220 (322,2)	6	AF - CM
				CS - CW
				CS JANUS PRO
1400 (55)	772 (1702)	1330 (351,3)	6	AF - CM
				CS - CW
				CS JANUS PRO

* weight of the tank excluding attachment

OPTIONAL

3	4
SUPPLEMENTARY BLADE	HB500 WELDED ADDITIONAL CUTTING EDGE

OPTIONAL

3	4
SUPPLEMENTARY BLADE	HB500 WELDED ADDITIONAL CUTTING EDGE



SA FORME ALLONGÉE EMPÊCHE QUE LE TERRAIN ADHÈRE AUX PAROIS LATÉRALES DU GODET ET FACILITE LE DECHARGEMENT DES MATÉRIEAUX ARGILEUX ET MOUILLÉS. LA LAME EST EN HB400 POUR ACCROÎTRE LEUR RÉSISTANCE À L'USURE.



CARACTERISTIQUES TECHNIQUES STANDARD

- 1 **PROFIL ALLONGÉ**
- 2 **BANDES DE RENFORCEMENT**
LES BANDES DE RENFORCEMENT HORIZONTALES PROTÈGENT LE FOND EN AUGMENTANT SA RÉSISTANCE À L'USURE.
- 3 **LAME EN HB400**
- 4 **DENTS DC DENTS DTE**

EN OPTION

- 5 **CONTRE-LAME HB500 SOUDÉE**
CONSEILLÉE POUR TRAVAILLER SUR TERRAINS ABRASIFS.

MOD.	MIDI EXCAVATOR											
	SCS 35GD	SCS 40GD	SCS 48GD	SCS 60GD	SCS 67GD	SCS 71GD	SCS 75GD	SCS 80GD	SCS 85GD	SCS 92GD	SCS 100GD	SCS 110GD
TONS	0,8 - 1,5	1,5 - 2,0	2,0 - 3,0	3,0 - 4,0	4,0 - 6,0	6,0 - 7,5	7,5 - 9,0	9,0 - 12,0	12,0 - 14,0	12,0 - 14,0	14,0 - 18,0	18,0 - 22,0

SCS35 GD POIDS MACHINE 0,8 - 1,5

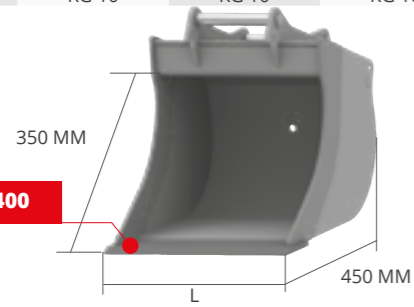

LAME EN HB400

EN OPTION

5
CONTRE-LAME HB500 SOUDÉE

L MM	POIDS KG*	CAP. SAE L	DENTS N°	ADAPTERS
250	17	25	3	AF - AR - CS
				CR - S - CM
				CW - CS JANUS PRO
300	20	30	3	AF - AR - CS
				CR - S - CM
				CW - CS JANUS PRO
400	26	42	3	AF - AR - CS
				CR - S - CM
				CW - CS JANUS PRO
500	31	54	4	AF - AR - CS
				CR - S - CM
				CW - CS JANUS PRO

SCS40 GD POIDS MACHINE 1,5 - 2,0

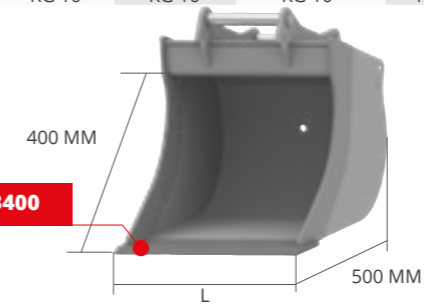

LAME EN HB400

EN OPTION

5
CONTRE-LAME HB500 SOUDÉE

L MM	POIDS KG*	CAP. SAE L	DENTS N°	ADAPTERS
300	23	35	3	AF - AR - CS
				CR - S - CM
				CW - CS JANUS PRO
400	30	45	3	AF - AR - CS
				CR - S - CM
				CW - CS JANUS PRO
500	38	60	4	AF - AR - CS
				CR - S - CM
				CW - CS JANUS PRO
600	45	85	4	AF - AR - CS
				CR - S - CM
				CW - CS JANUS PRO

SCS48 GD POIDS MACHINE 2,0 - 3,0

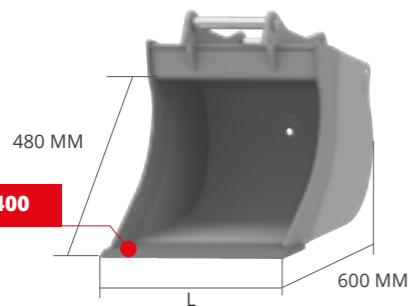

LAME EN HB400

EN OPTION

5
CONTRE-LAME HB500 SOUDÉE

L MM	POIDS KG*	CAP. SAE L	DENTS N°	ADAPTERS
300	34	48	3	AF - AR - CS
				CR - S - CM
				CW - CS JANUS PRO
400	43	68	3	AF - AR - CS
				CR - S - CM
				CW - CS JANUS PRO
500	55	85	4	AF - AR - CS
				CR - S - CM
				CW - CS JANUS PRO
600	65	110	4	AF - AR - CS
				CR - S - CM
				CW - CS JANUS PRO
800	90	160	5	AF - AR - CS
				CR - S - CM
				CW - CS JANUS PRO

SCS60 GD POIDS MACHINE 3,0 - 4,0

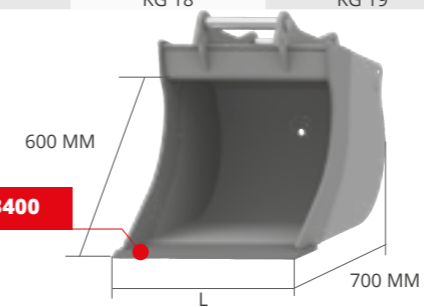

LAME EN HB400

EN OPTION

5
CONTRE-LAME HB500 SOUDÉE

L MM	POIDS KG*	CAP. SAE L	DENTS N°	ADAPTERS
300	44	78	3	AF - AR - CS
				CR - S - CM
				CW - CS JANUS PRO
400	54	105	3	AF - AR - CS
				CR - S - CM
				CW - CS JANUS PRO
500	66	140	4	AF - AR - CS
				CR - S - CM
				CW - CS JANUS PRO
600	80	165	4	AF - AR - CS
				CR - S - CM
				CW - CS JANUS PRO
800	100	225	5	AF - AR - CS
				CR - S - CM
				CW - CS JANUS PRO

* poids cuve sans attache

* poids cuve sans attache

SCS67 GD POIDS MACHINE 4,0 - 6,0

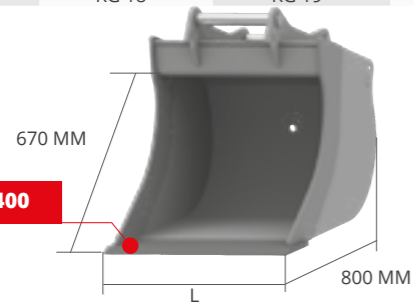

EN OPTION

5
CONTRE-LAME HB500 SOUDÉE

L MM	POIDS KG*	CAP. SAE L	DENTS N°	ADAPTERS
300	65	90	3	AF - AR - CS CR - S - CM CW - CS JANUS PRO
400	73	130	3	AF - AR - CS CR - S - CM CW - CS JANUS PRO
500	91	170	4	AF - AR - CS CR - S - CM CW - CS JANUS PRO
600	106	200	4	AF - AR - CS CR - S - CM CW - CS JANUS PRO
800	140	280	5	AF - AR - CS CR - S - CM CW - CS JANUS PRO

SCS71 GD POIDS MACHINE 6,0 - 7,5

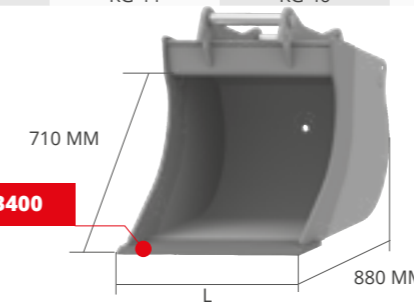
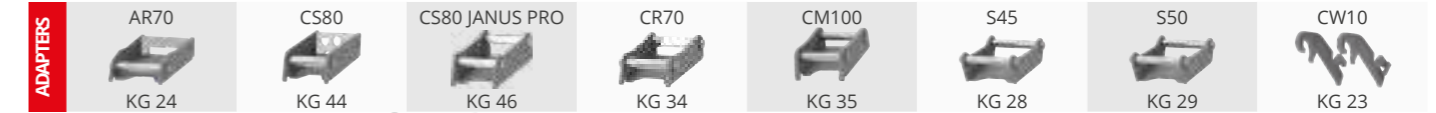

EN OPTION

5
CONTRE-LAME HB500 SOUDÉE

L MM	POIDS KG*	CAP. SAE L	DENTS N°	ADAPTERS
400	94	150	3	AF - AR - CS CR - S - CM CW - CS JANUS PRO
500	114	190	4	AF - AR - CS CR - S - CM CW - CS JANUS PRO
600	136	230	4	AF - AR - CS CR - S - CM CW - CS JANUS PRO
700	156	260	5	AF - AR - CS CR - S - CM CW - CS JANUS PRO
800	174	315	5	AF - AR - CS CR - S - CM CW - CS JANUS PRO

SCS75 GD POIDS MACHINE 7,5 - 9,0

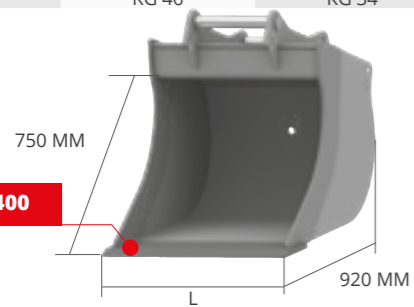

EN OPTION

5
CONTRE-LAME HB500 SOUDÉE

L MM	POIDS KG*	CAP. SAE L	DENTS N°	ADAPTERS
400	108	165	3	AF - CS CR - S - CM CW - CS JANUS PRO
500	128	210	4	AF - CS CR - S - CM CW - CS JANUS PRO
600	150	260	4	AF - CS CR - S - CM CW - CS JANUS PRO
700	175	300	5	AF - CS CR - S - CM CW - CS JANUS PRO
800	194	350	5	AF - CS CR - S - CM CW - CS JANUS PRO
1000	231	450	5	AF - CS CR - S - CM CW - CS JANUS PRO

SCS80 GD POIDS MACHINE 9,0 - 12,0

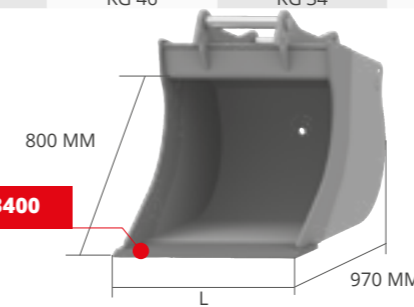

EN OPTION

5
CONTRE-LAME HB500 SOUDÉE

L MM	POIDS KG*	CAP. SAE L	DENTS N°	ADAPTERS
400	118	190	3	AF - CS CR - S - CM CW - CS JANUS PRO
500	135	245	3	AF - CS CR - S - CM CW - CS JANUS PRO
600	157	300	4	AF - CS CR - S - CM CW - CS JANUS PRO
700	185	350	4	AF - CS CR - S - CM CW - CS JANUS PRO
800	207	400	5	AF - CS CR - S - CM CW - CS JANUS PRO
1000	250	500	5	AF - CS CR - S - CM CW - CS JANUS PRO

* poids cuve sans attache

* poids cuve sans attache

SCS85 GD **MIDI** POIDS MACHINE 12,0 - 14,0

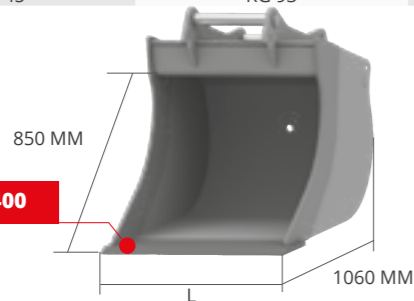

EN OPTION

5
CONTRE-LAME HB500 SOUDÉE

L MM	POIDS KG*	CAP. SAE L	DENTS N°	ADAPTERS
500	175	265	3	AF - S - CM CS - CW CS JANUS PRO
600	200	330	4	AF - S - CM CS - CW CS JANUS PRO
700	228	400	4	AF - S - CM CS - CW CS JANUS PRO
800	253	450	5	AF - S - CM CS - CW CS JANUS PRO
900	278	500	5	AF - S - CM CS - CW CS JANUS PRO
1000	305	580	5	AF - S - CM CS - CW CS JANUS PRO
1200	340	740	6	AF - S - CM CS - CW CS JANUS PRO

SCS92 GD **EXCAVATOR** POIDS MACHINE 12,0 - 14,0

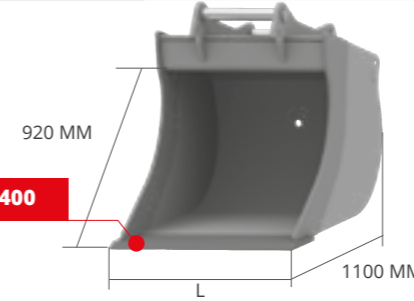

EN OPTION

5
CONTRE-LAME HB500 SOUDÉE

L MM	POIDS KG*	CAP. SAE L	DENTS N°	ADAPTERS
600	228	380	4	AF - S - CM CS - CW CS JANUS PRO
700	251	450	4	AF - S - CM CS - CW CS JANUS PRO
800	281	560	4	AF - S - CM CS - CW CS JANUS PRO
900	309	620	5	AF - S - CM CS - CW CS JANUS PRO
1000	350	700	5	AF - S - CM CS - CW CS JANUS PRO
1200	403	900	6	AF - S - CM CS - CW CS JANUS PRO

SCS100 GD POIDS MACHINE 14,0 - 18,0

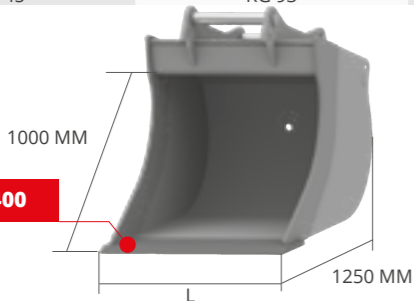

EN OPTION

5
CONTRE-LAME HB500 SOUDÉE

L MM	POIDS KG*	CAP. SAE L	DENTS N°	ADAPTERS
600	316	450	3	AF - S - CM CS - CW CS JANUS PRO
700	355	535	4	AF - S - CM CS - CW CS JANUS PRO
800	394	620	4	AF - S - CM CS - CW CS JANUS PRO
900	433	710	4	AF - S - CM CS - CW CS JANUS PRO
1000	472	800	5	AF - S - CM CS - CW CS JANUS PRO
1200	550	980	5	AF - S - CM CS - CW CS JANUS PRO

SCS110 GD POIDS MACHINE 18,0 - 22,0

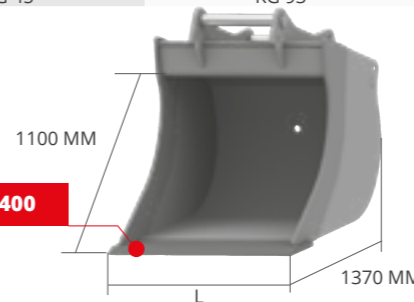

EN OPTION

5
CONTRE-LAME HB500 SOUDÉE

L MM	POIDS KG*	CAP. SAE L	DENTS N°	ADAPTERS
600	412	480	3	AF - S - CM CS - CW CS JANUS PRO
800	502	690	4	AF - S - CM CS - CW CS JANUS PRO
1000	592	900	5	AF - S - CM CS - CW CS JANUS PRO
1200	682	1110	5	AF - S - CM CS - CW CS JANUS PRO
1300	727	1220	6	AF - S - CM CS - CW CS JANUS PRO
1400	772	1330	6	AF - S - CM CS - CW CS JANUS PRO

* poids cuve sans attache

* poids cuve sans attache



HB400



SA FORME ALLONGÉE EMPÊCHE QUE LE TERRAIN ADHÈRE AUX PAROIS LATÉRALES DU GODET ET FACILITE LE DECHARGEMENT DES MATÉRIAUX ARGILEUX ET MOUILLÉS. LA LAME, LES TRANCHANTS ET PLAQUES LATÉRALES ET LES BANDES POSTÉRIEURES SONT RÉALISÉES EN HB400.

MOD.	MIDI EXCAVATOR											
	SCS 35HD	SCS 40HD	SCS 48HD	SCS 60HD	SCS 67HD	SCS 71HD	SCS 75HD	SCS 80HD	SCS 85HD	SCS 92HD	SCS 100HD	SCS 110HD
TONS	0,8 - 1,5	1,5 - 2,0	2,0 - 3,0	3,0 - 4,0	4,0 - 6,0	6,0 - 7,5	7,5 - 9,0	9,0 - 12,0	12,0 - 14,0	12,0 - 14,0	14,0 - 18,0	18,0 - 22,0

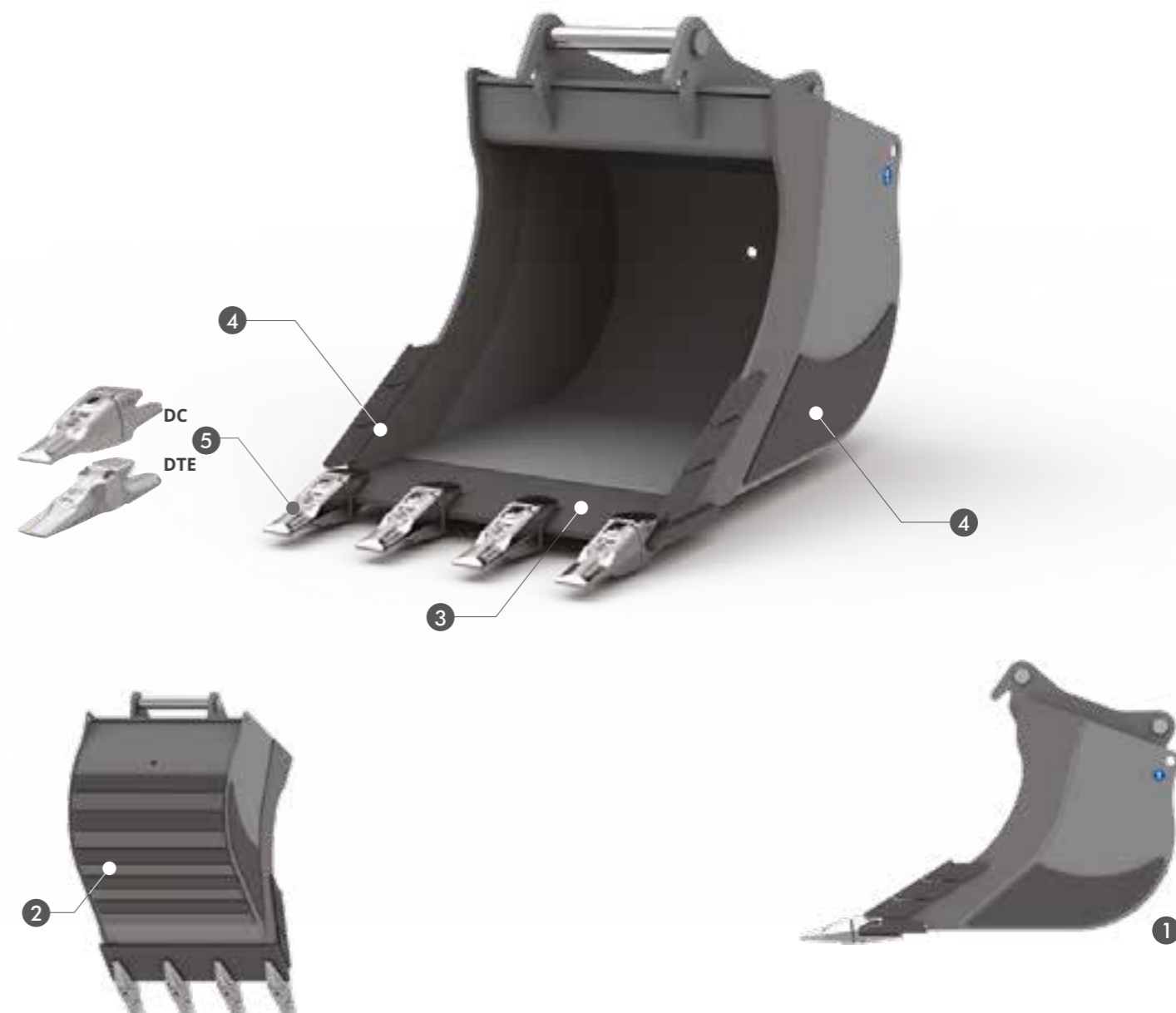

CARACTERISTIQUES TECHNIQUES STANDARD

- 1 PROFIL ALLONGÉ**
- 2 BANDES DE RENFORCEMENT HB 400**
LES BANDES DE RENFORCEMENT HORIZONTALES PROTÈGENT LE FOND EN AUGMENTANT SA RÉSISTANCE À L'USURE.
- 3 LAME EN HB400**
- 4 TRANCHANTS ET PLAQUES LATÉRALES DE RENFORCEMENT EN FUSION HB400**
RÉALISÉS EN FUSION HB400 ET PLACÉS SUR LES SURFACES LES PLUS EXPOSÉES DONNENT PLUS DE RÉSISTANCE À L'USURE.
- 5 DENTS DC DENTS DTE**

SCS35 HD POIDS MACHINE 0,8 - 1,5

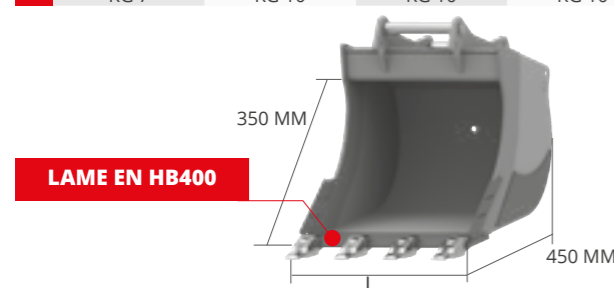

L MM	POIDS KG*	CAP. SAE L	DENTS N°	ADAPTERS
250	20	22	3	AF - AR - CS
				CR - S - CM
				CW - CS JANUS PRO
300	24	26	3	AF - AR - CS
				CR - S - CM
				CW - CS JANUS PRO
400	30	40	3	AF - AR - CS
				CR - S - CM
				CW - CS JANUS PRO
500	35	50	4	AF - AR - CS
				CR - S - CM
				CW - CS JANUS PRO

SCS40 HD POIDS MACHINE 1,5 - 2,0

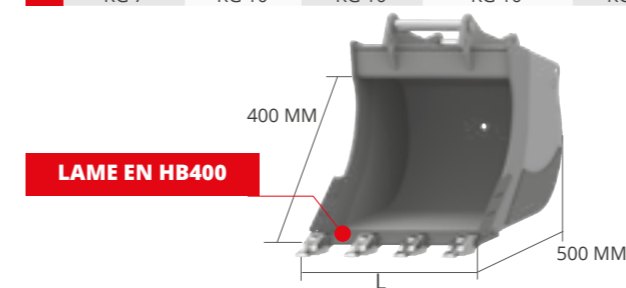

L MM	POIDS KG*	CAP. SAE L	DENTS N°	ADAPTERS
300	26	35	3	AF - AR - CS
				CR - S - CM
				CW - CS JANUS PRO
400	34	45	3	AF - AR - CS
				CR - S - CM
				CW - CS JANUS PRO
500	42	60	4	AF - AR - CS
				CR - S - CM
				CW - CS JANUS PRO
600	49	85	4	AF - AR - CS
				CR - S - CM
				CW - CS JANUS PRO

SCS48 HD POIDS MACHINE 2,0 - 3,0

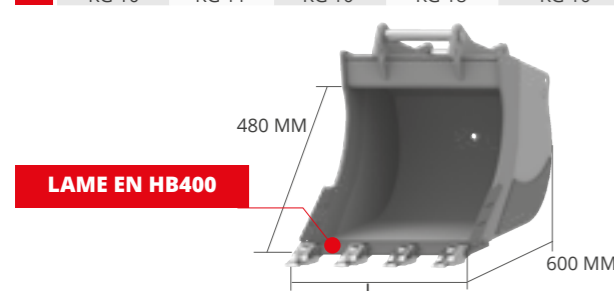

L MM	POIDS KG*	CAP. SAE L	DENTS N°	ADAPTERS
300	38	48	3	AF - AR - CS
				CR - S - CM
				CW - CS JANUS PRO
400	48	68	3	AF - AR - CS
				CR - S - CM
				CW - CS JANUS PRO
500	61	85	4	AF - AR - CS
				CR - S - CM
				CW - CS JANUS PRO
600	72	110	4	AF - AR - CS
				CR - S - CM
				CW - CS JANUS PRO
800	98	160	5	AF - AR - CS
				CR - S - CM
				CW - CS JANUS PRO

SCS60 HD POIDS MACHINE 3,0 - 4,0

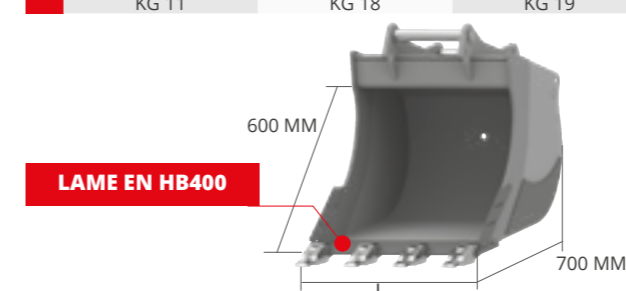
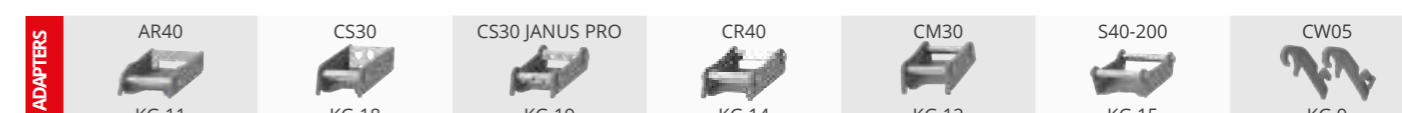

L MM	POIDS KG*	CAP. SAE L	DENTS N°	ADAPTERS
300	52	78	3	AF - AR - CS
				CR - S - CM
				CW - CS JANUS PRO
400	63	105	3	AF - AR - CS
				CR - S - CM
				CW - CS JANUS PRO
500	76	140	4	AF - AR - CS
				CR - S - CM
				CW - CS JANUS PRO
600	91	165	4	AF - AR - CS
				CR - S - CM
				CW - CS JANUS PRO
800	112	225	5	AF - AR - CS
				CR - S - CM
				CW - CS JANUS PRO

* poids cuve sans attache

* poids cuve sans attache

SCS67 HD POIDS MACHINE 4,0 - 6,0

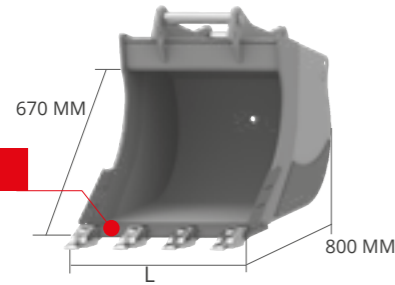

L MM	POIDS KG*	CAP. SAE L	DENTS N°	ADAPTERS
300	75	90	3	AF - AR - CS CR - S - CM CW - CS JANUS PRO
400	85	130	3	AF - AR - CS CR - S - CM CW - CS JANUS PRO
500	105	170	4	AF - AR - CS CR - S - CM CW - CS JANUS PRO
600	122	200	4	AF - AR - CS CR - S - CM CW - CS JANUS PRO
800	160	280	5	AF - AR - CS CR - S - CM CW - CS JANUS PRO

SCS71 HD POIDS MACHINE 6,0 - 7,5

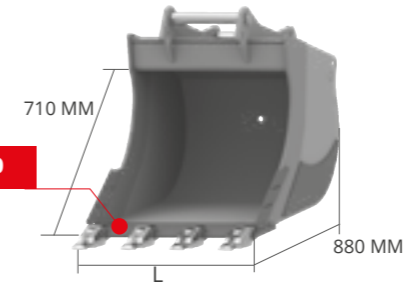
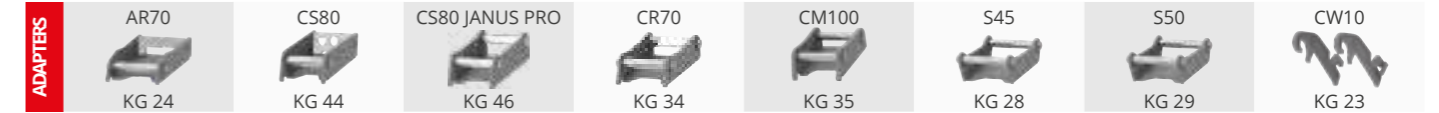

L MM	POIDS KG*	CAP. SAE L	DENTS N°	ADAPTERS
400	108	150	3	AF - AR - CS CR - S - CM CW - CS JANUS PRO
500	130	190	4	AF - AR - CS CR - S - CM CW - CS JANUS PRO
600	154	230	4	AF - AR - CS CR - S - CM CW - CS JANUS PRO
700	176	260	5	AF - AR - CS CR - S - CM CW - CS JANUS PRO
800	197	315	5	AF - AR - CS CR - S - CM CW - CS JANUS PRO

SCS75 HD POIDS MACHINE 7,5 - 9,0

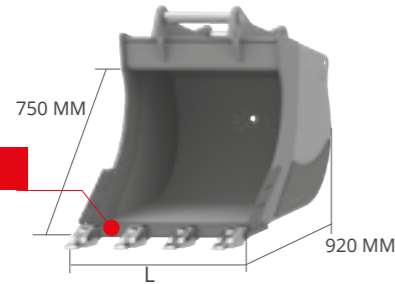

L MM	POIDS KG*	CAP. SAE L	DENTS N°	ADAPTERS
400	123	165	3	AF - CS CR - S - CM CW - CS JANUS PRO
500	145	210	4	AF - CS CR - S - CM CW - CS JANUS PRO
600	170	260	4	AF - CS CR - S - CM CW - CS JANUS PRO
700	198	300	5	AF - CS CR - S - CM CW - CS JANUS PRO
800	220	350	5	AF - CS CR - S - CM CW - CS JANUS PRO
1000	263	450	5	AF - CS CR - S - CM CW - CS JANUS PRO

SCS80 HD POIDS MACHINE 9,0 - 12,0

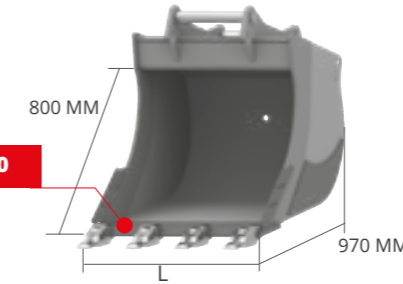

L MM	POIDS KG*	CAP. SAE L	DENTS N°	ADAPTERS
400	133	190	3	AF - CS CR - S - CM CW - CS JANUS PRO
500	153	245	3	AF - CS CR - S - CM CW - CS JANUS PRO
600	178	300	4	AF - CS CR - S - CM CW - CS JANUS PRO
700	209	350	4	AF - CS CR - S - CM CW - CS JANUS PRO
800	234	400	5	AF - CS CR - S - CM CW - CS JANUS PRO
1000	283	500	5	AF - CS CR - S - CM CW - CS JANUS PRO

* poids cuve sans attache

* poids cuve sans attache

SCS85 HD **MIDI** POIDS MACHINE 12,0 - 14,0

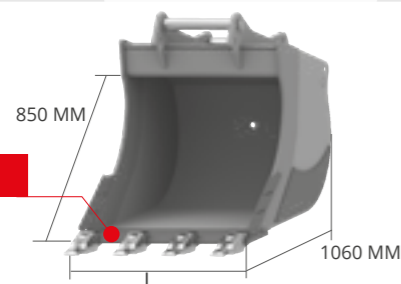

L MM	POIDS KG*	CAP. SAE L	DENTS N°	ADAPTERS
500	197	265	3	AF - S - CM CS - CW CS JANUS PRO
600	225	330	4	AF - S - CM CS - CW CS JANUS PRO
700	256	400	4	AF - S - CM CS - CW CS JANUS PRO
800	284	450	5	AF - S - CM CS - CW CS JANUS PRO
900	312	500	5	AF - S - CM CS - CW CS JANUS PRO
1000	342	580	5	AF - S - CM CS - CW CS JANUS PRO
1200	383	740	6	AF - S - CM CS - CW CS JANUS PRO

SCS92 HD **EXCAVATOR** POIDS MACHINE 12,0 - 14,0

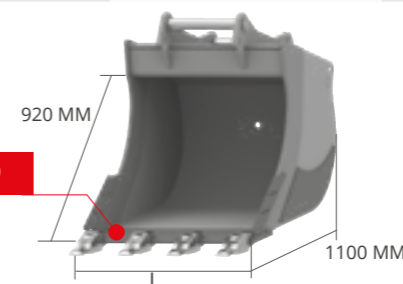

L MM	POIDS KG*	CAP. SAE L	DENTS N°	ADAPTERS
600	261	380	4	AF - S - CM CS - CW CS JANUS PRO
700	287	450	4	AF - S - CM CS - CW CS JANUS PRO
800	320	560	5	AF - S - CM CS - CW CS JANUS PRO
900	352	620	5	AF - S - CM CS - CW CS JANUS PRO
1000	395	700	5	AF - S - CM CS - CW CS JANUS PRO
1200	454	900	6	AF - S - CM CS - CW CS JANUS PRO

SCS100 HD POIDS MACHINE 14,0 - 18,0

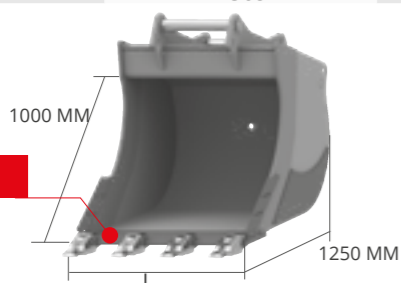

L MM	POIDS KG*	CAP. SAE L	DENTS N°	ADAPTERS
600	353	450	3	AF - S - CM CS - CW CS JANUS PRO
700	397	535	4	AF - S - CM CS - CW CS JANUS PRO
800	441	620	4	AF - S - CM CS - CW CS JANUS PRO
900	485	710	4	AF - S - CM CS - CW CS JANUS PRO
1000	529	800	5	AF - S - CM CS - CW CS JANUS PRO
1200	617	980	5	AF - S - CM CS - CW CS JANUS PRO

SCS110 HD POIDS MACHINE 18,0 - 22,0

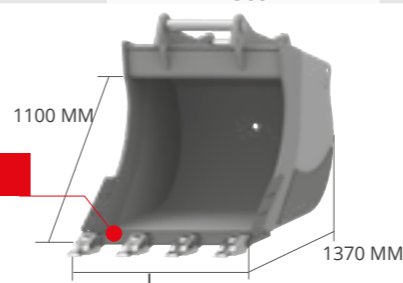

L MM	POIDS KG*	CAP. SAE L	DENTS N°	ADAPTERS
600	457	480	3	AF - S - CM CS - CW CS JANUS PRO
800	559	690	4	AF - S - CM CS - CW CS JANUS PRO
1000	671	900	5	AF - S - CM CS - CW CS JANUS PRO
1200	773	1110	5	AF - S - CM CS - CW CS JANUS PRO
1300	824	1220	6	AF - S - CM CS - CW CS JANUS PRO
1400	875	1330	6	AF - S - CM CS - CW CS JANUS PRO

* poids cuve sans attache

* poids cuve sans attache

HB400



SA FORME ALLONGÉE EMPÊCHE QUE LE TERRAIN ADHÈRE AUX PAROIS LATÉRALES DU GODET ET FACILITE LE DECHARGEMENT DES MATÉRIAUX ARGILEUX ET MOUILLÉS. LE GODET HOLLANDE EST ÉQUIPÉ DE LAME EN HB400.

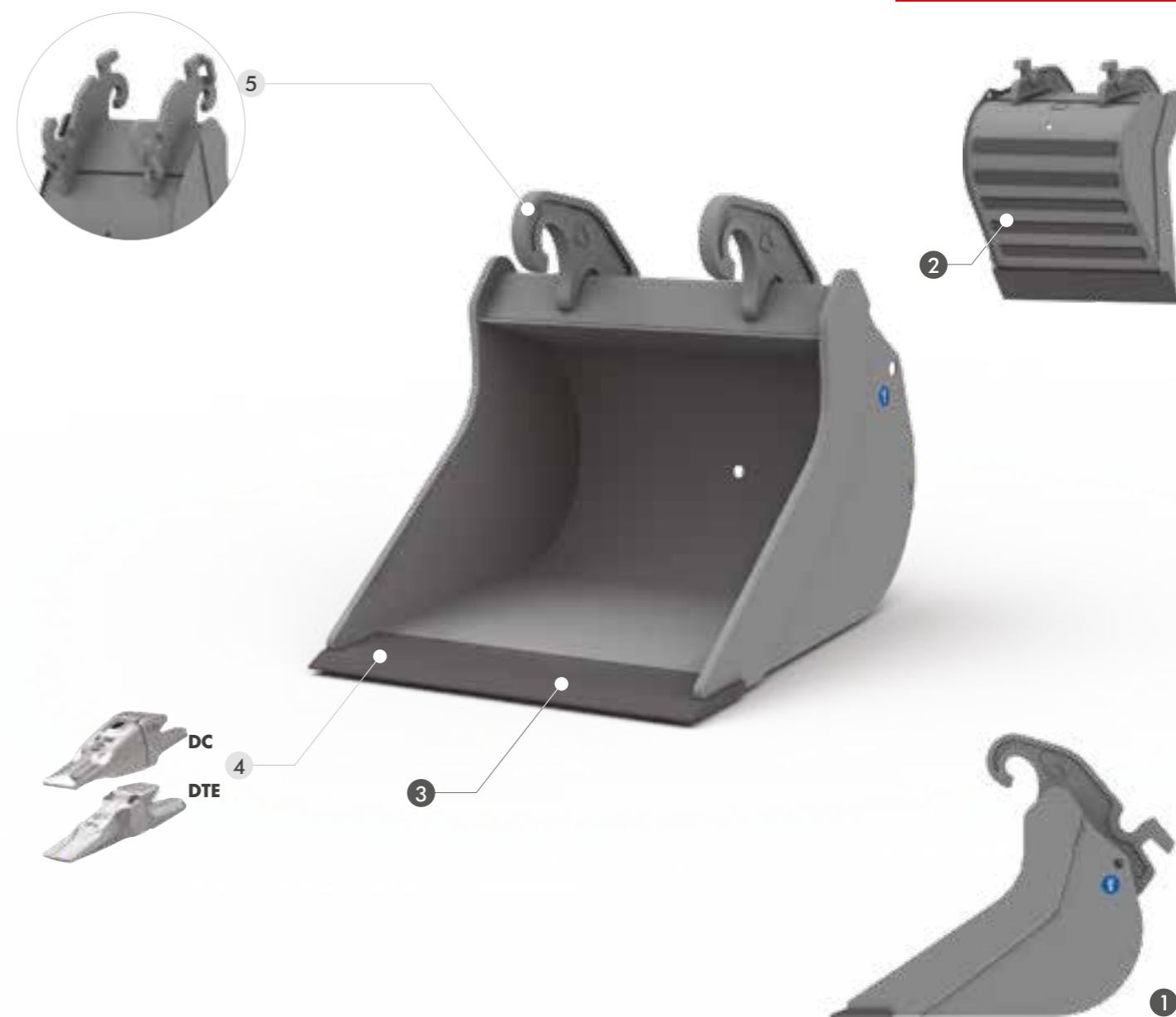

CHARACTERISTIQUES TECHNIQUES STANDARD

- 1 **PROFIL ALLONGÉ**
- 2 **BANDES DE RENFORCEMENT**
LES BANDES DE RENFORCEMENT HORIZONTALES PROTÈGENT LE FOND EN AUGMENTANT SA RÉSISTANCE À L'USURE.
- 3 **LAME EN HB400**

EN OPTION

- 4 **DENTS DC OU DENTS DTE**
- 5 **VERSION RÉVERSIBLE CW**
CET ADAPTEUR PERMET DE RENDRE LE GODET RÉVERSIBLE.

MOD.	SCN35	SCN41	SCN52	SCN60	SCN66	SCN75	SCN85
TONS	0,6 - 1,2	1,2 - 1,8	1,8 - 2,5	2,5 - 4,0	4,0 - 6,0	6,0 - 7,5	7,5 - 12,0

SCN35 POIDS MACHINE 0,6 - 1,2

ADAPTERS

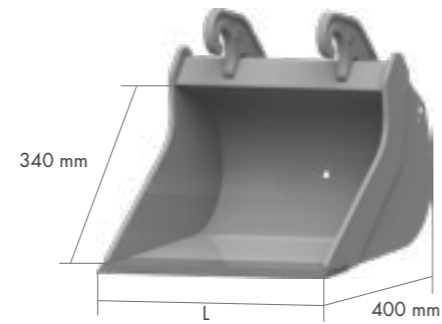

EN OPTION

4	4	5
Dents DC	Dents DTE	Version réversible CW

L mm	POIDS Kg*	CAP. SAE l	
300	19	21	AF
300	19	21	CW
400	23	31	AF
400	23	31	CW
500	28	47	AF
500	28	47	CW

SCN41 POIDS MACHINE 1,2 - 1,8

ADAPTERS



EN OPTION

4	4	5
Dents DC	Dents DTE	Version réversible CW

L mm	POIDS Kg*	CAP. SAE l	
300	22	26	AF
300	22	26	CW
400	27	38	AF
400	27	38	CW
500	33	52	AF
500	33	52	CW
600	38	75	AF
600	38	75	CW

SCN52 POIDS MACHINE 1,8 - 2,5

ADAPTERS

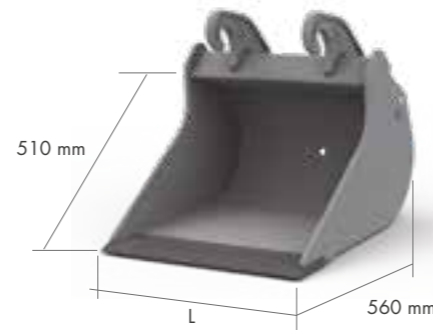

EN OPTION

4	4	5
Dents DC	Dents DTE	Version réversible CW

L mm	POIDS Kg*	CAP. SAE l	
300	32	34	AF
300	32	34	CW
400	40	51	AF
400	40	51	CW
500	47	69	AF
500	47	69	CW
600	54	87	AF
600	54	87	CW

SCN60 POIDS MACHINE 2,5 - 4,0

ADAPTERS

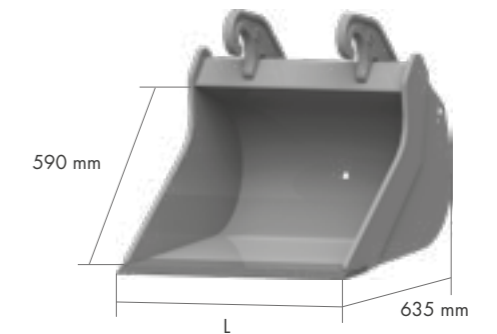

EN OPTION

4	4	5
Dents DC	Dents DTE	Version réversible CW

L mm	POIDS Kg*	CAP. SAE l	
300	41	46	AF
300	41	46	CW
400	49	69	AF
400	49	69	CW
500	57	93	AF
500	57	93	CW
600	65	118	AF
600	65	118	CW

* poids cuve sans attache

* poids cuve sans attache

SCN66 POIDS MACHINE 4,0 - 6,0

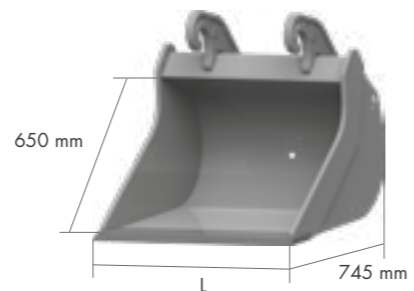

ADAPTERS

CW10
KG 23



L mm	POIDS Kg*	CAP. SAE l	
400	65	79	AF
400	65	79	CW
500	75	107	AF
500	75	107	CW
600	86	137	AF
600	86	137	CW
700	97	168	AF
700	97	168	CW

EN OPTION

		
Dents DC	Dents DTE	Version réversible CW

SCN75 POIDS MACHINE 6,0 - 7,5

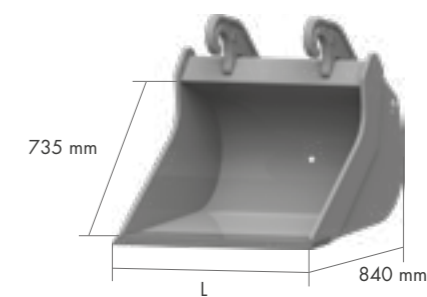

ADAPTERS

CW10
KG 23



L mm	POIDS Kg*	CAP. SAE l	
400	85	94	AF
400	85	94	CW
500	100	128	AF
500	100	128	CW
600	114	165	AF
600	114	165	CW
700	128	203	AF
700	128	203	CW
800	142	243	AF
800	142	243	CW

EN OPTION

		
Dents DC	Dents DTE	Version réversible CW

SCN85 POIDS MACHINE 7,5 - 12,0

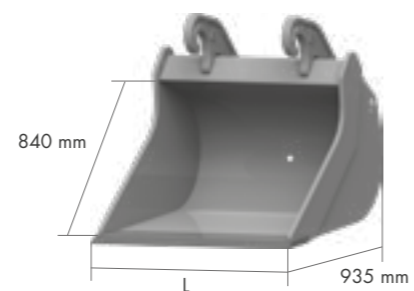

ADAPTERS

CW10
KG 23



L mm	POIDS Kg*	CAP. SAE l	
400	98	121	AF
400	98	121	CW
500	112	160	AF
500	112	160	CW
600	127	205	AF
600	127	205	CW
700	142	252	AF
700	142	252	CW
800	157	301	AF
800	157	301	CW
900	172	352	AF
900	172	352	CW

EN OPTION

		
Dents DC	Dents DTE	Version réversible CW

