

CORMACH



6800 E



Valvola flangiata sui cilindri per > sicurezza.

Flanged valve on the cylinder for > safety.

Clapet de securite flasquée sur le verin pour > sécurité.

Direkt aufgebaute Ventile für > Sicherheit.

Torretta a sezione chiusa con massima rigidità torsionale.

Close section swivel post with maximum torsional rigidity.

Tourelle à section fermée avec très haute rigidité torsionnelle.

Geteilte Kransäule ergibt eine hohe Drehfestigkeit.

Corsa dei telescopi extra lunga per uno sbraccio massimo idraulico di metri 8,40 (6800 E-3).

Telescopic cylinders with very long stroke for a maximum hydraulic range of m. 8,40 (6800 E-3).

Course très longue des cylindres télescopiques, pour une détente du bras hydraulique de mètres max. 8,40 (6800 E-3).

Superlanger Teleskopausschub für eine Reichweite von 8,40 m. (6800 E-3).

Rotazione con motore e riduttore: potenza, affidabilità, sensibilità al comando. Freno idraulico. A richiesta rotazione continua.

Rotation with engine and reduction gear, power, reliability, remarkable drive sensibility. Hydraulic brake. (Option of continuous rotation).

Rotation par lotoreducteur avec frein hydraulique. (Rotation continue sur demande).

Drehung durch Motor Undgetriebe hochleistung. Zuverlässigkeit. Hydraulischer Bremse. (Endlosdrehung auf frage).

Piedi stabilizzatori girevoli di serie.

Flip up stabilising cylinders.

Stabilisateurs tournants.

Drehebare Absützbeine.

Cuscinetto di base a rulli, massima resistenza, precisione di movimento, minimo attrito, nessuna usura.

Highly resistant base roller bearing, outstanding motion precision, very little friction, no wear.

Palier de base à rouleaux, de max. résistance, precision des mouvements, minimum de friction, pas d'usure.

Sonderfestes Schrägrollenlager, ideale Bewegungsgenauigkeit, niedrige Reibung, hohe Verschleißfestigkeit.

Attacco al telaio oscillante in conformità alle specifiche dei maggiori costruttori di veicoli industriali.

3 Point linkage as required by the leading truck producers.

Attaque au basement oscillant en conformité aux prescriptions des principaux constructeurs de véhicules industriels.

Torsionsbrücke nach Vorschrift der LKW-Hersteller.



GORMAGH

Perni in acciaio speciale.
Pins in special steel.
Pivot en acier spécial.
Bolzen aus Sonderstahl.

Boccole in materiale autolubrificante (condizione limite).
Bushes made in selflubricating material.
Boîtes en matériel autolubrifiant.
Büchsen aus selbstschmierendem Material.

Compattezza: 8,40 m. di braccio idraulico, 6,8 t·m di capacità in uno spazio di 0,6 x 2,2 x 1,7 (compreso serbatoio).

Compactness: hydraulic operated forward reach 8,40 m. capacity 6,8 t·m with size 0,6 x 2,2 x 1,7 (with oil tank).

Compacité: rayon d'action hydraulique à 8,40 m. capacité 6,8 t·m avec dimensions 0,6 x 2,2 x 1,7 (avec réservoir).

Kompaktheit: geringe Einbaumaße 0,6 x 2,2 x 1,7 (mit Öl Tank), bei einem Hubmoment von 6,8 t·m und einer hydr. Reichweite von 8,40 m.

Braccio sagomato con sezione chiusa, massima resistenza a torsione e massima leggerezza della struttura.

Shaped arm with closed section, max. resistance to torsional stress, and light structure.

Bras à coupe fermée, permettant une haute résistance à la torsion, et structure très légère.

Geschlossener Hubarm mit hoher Verdrehfestigkeit, leichtes Gewicht.

Filtrazione aria-olio.
Air-oil filter.
Filtre air et huile.
Luft-Öl Filter.

Braccio telescopico a sezione esagonale > resistenza.

Telescopic boom with hexagonal section > resistance.

Bras à section hexagonal > résistance.

Ausschub aus Sechskantprofil für > Festigkeit.

Indicatori dello stato di carico di serie.

Load condition indicator.

Indicateurs de l'état de chargement de serie.

Belastungsanzeiger.

Opzione: sfilo idraulico stabilizzatori con cilindri protetti.

Option: outriggers hydraulic extension with protected cylinders.

Option: stabilisateur avec élargissement hydraulique avec verins protégés.

Option: abgedeckte Hydraulisch Ausfahrbare Absstützylinder.

6800E

... ABOUT ANCIENT

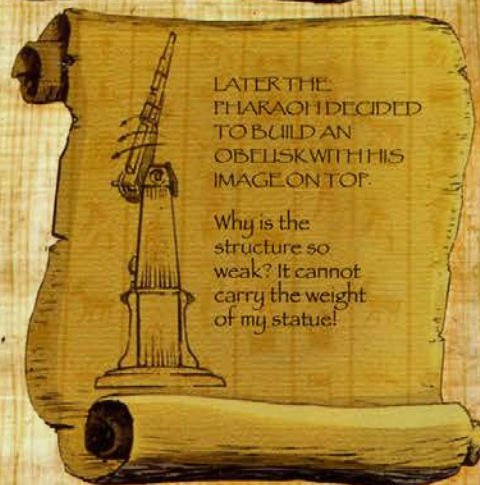
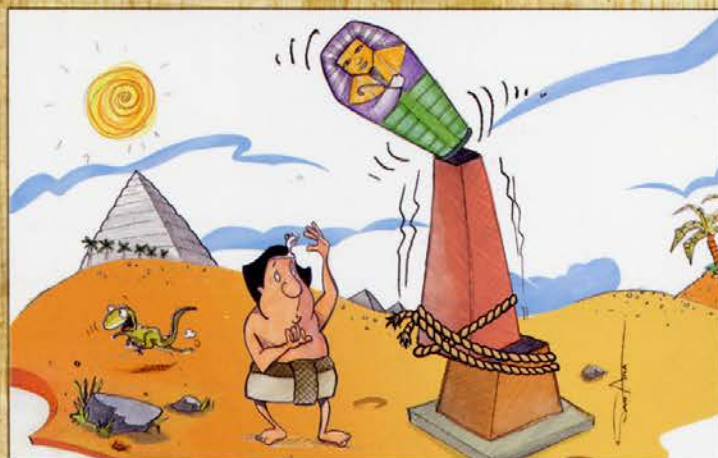
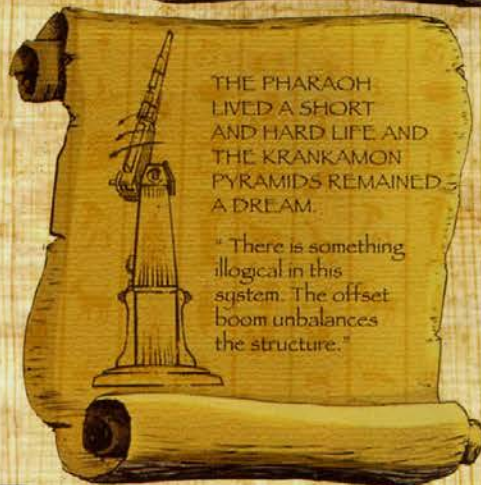
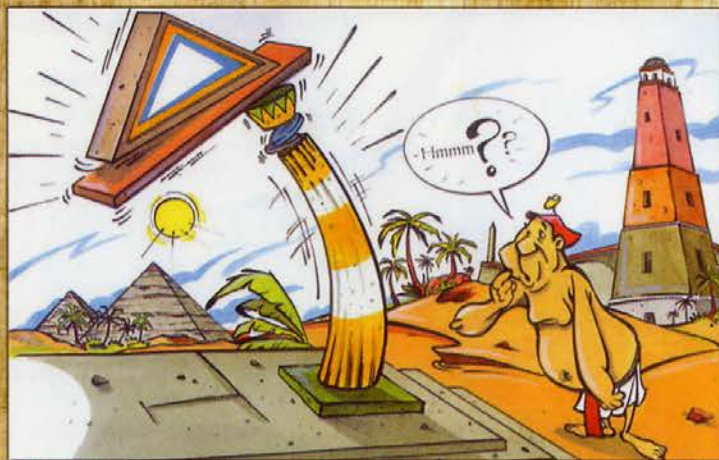
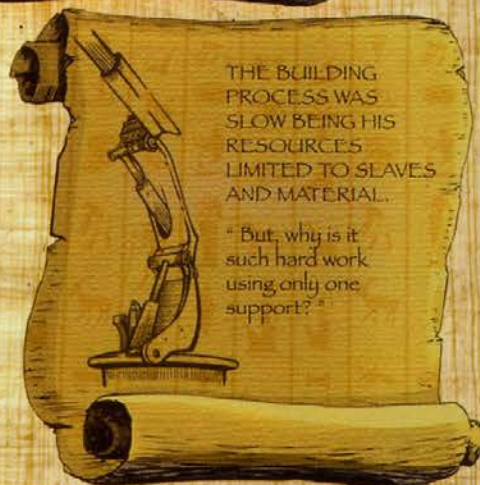
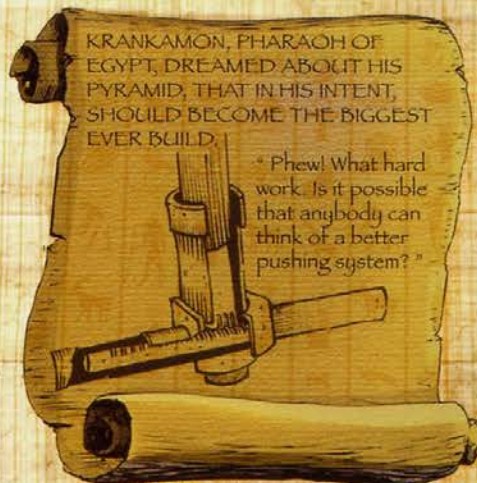

EGYPT MANUSCRIPTS

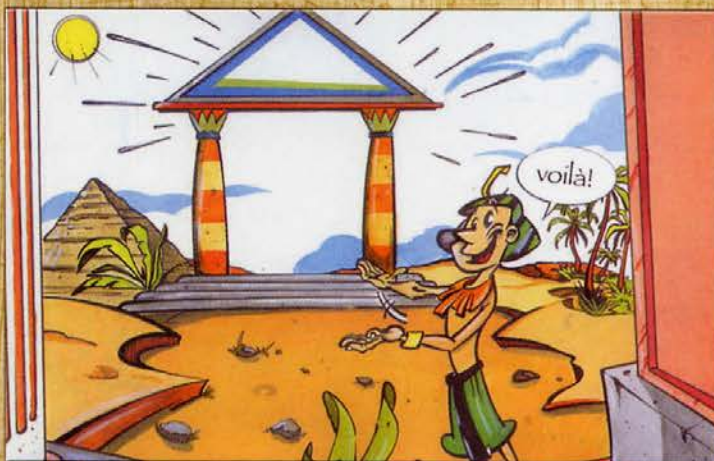

6800 E





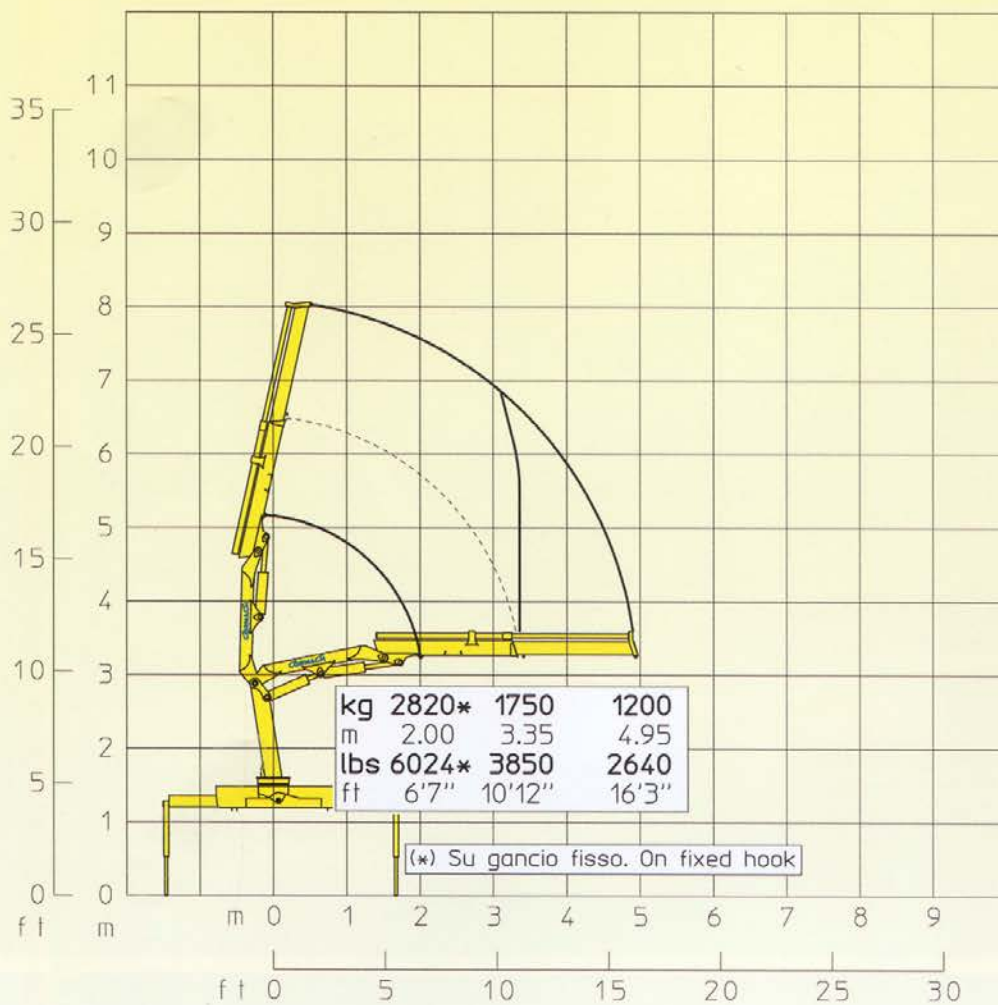

E1		E2		E3	
m/ft	kg/lbs	m/ft	kg/lbs	m/ft	kg/lbs
2.00 6'7"	2820* 6204*	2.00 6'7"	2760* 6079*	2.00 6'7"	2660* 5852*
3.35 10'12"	1750 3850	3.40 11'2"	1690 3718	3.47 11'5"	1610 3542
4.95 16'3"	1200 2640	5.00 16'5"	1160 2550	5.05 16'7"	1080 2376
		6.60 21'8"	870 1914	6.60 21'8"	800 1760
				8.30 27'3"	640 1408

(*) Su gancio fisso - On fixed hook



E1	E1	
6800 daN*m	49194 Lb*ft	Momento statico massimo al perno torretta • Max. static moment at the turret pin Moment statique max. a l'axe de la tourelle • Max. statisches ubmoment am kran Saulenbolzen
4.95 m	16'3"	Sbraccio idraulico • Hydraulic boom length Longueur du bras hydraulique • Hydraulische reichweite
		Sbraccio con prolunghe manuali • Bomm length with manual extensions Longueur du bras avec rallonges manuelles
680 daN*m	4919 Lb*ft	Coppia di rotazione • Slew torque • Moment de rotation • Drehmoment
40 sec 360°	40 sec 360°	Tempo di rotazione • Slewing speed • Temp de rotation • Schwenkgeschwindigkeit
1200+1200mm	3'11"+3'11"	Uscita stabilizzatori (*) • Outriggers extensions (*) Sortie des bequilles (*) • Breite der abstützung (*)
4495 mm	14'9"	Larghezza stabilizzatori (***) • Outriggers width (***) Largeur des bequilles (***) • Breite der abstützung (***)
624 mm	2'1"	Lunghezza • Length • Longeur • Länge
2190 mm	7'2"	Larghezza • Width • Largeur • Breite
1710 mm	5'7"	Altezza • Height • Huteur • Höhe
920 kg	2028 lbs	Peso (senza olio e montaggio) • Weight (without oil and fitting) Poids (sans huile et montage) • Gewicht (ohne öl und ohne)
14 l/min	4 us gal/min	Portata pompa (***) • Pump delivery (***) • Capacité de la pompe (***) • Pumpenleistung (***)
275 bar	3911 psi	Pressione • Pressure • Pression • Druck
31 l	8 us gal	Capacità serbatoio olio • Oil tank capacity • Capacité de reservoir d'huile • Öl tank inhalt

STANDARD



OPTIONAL

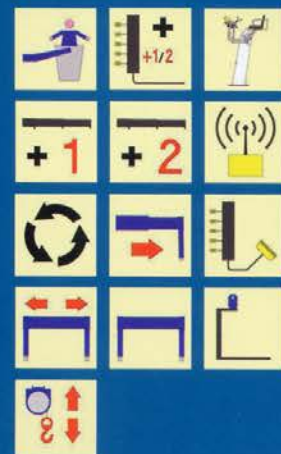

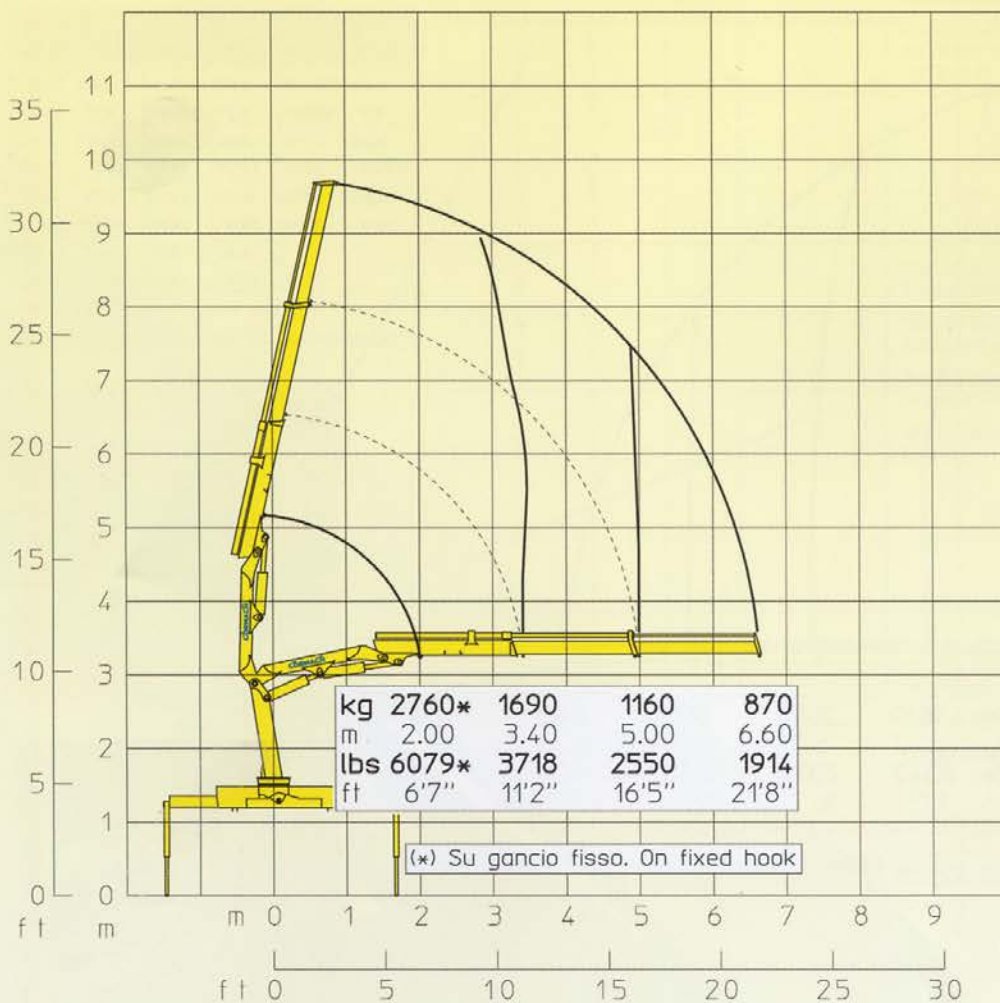

E1		E2		E3	
m/ft	kg/lbs	m/ft	kg/lbs	m/ft	kg/lbs
2.00 6'7"	2820* 6204*	2.00 6'7"	2760* 6079*	2.00 6'7"	2660* 5852*
3.35 10'12"	1750 3850	3.40 11'2"	1690 3718	3.47 11'5"	1610 3542
4.95 16'3"	1200 2640	5.00 16'5"	1160 2550	5.05 16'7"	1080 2376
		6.60 21'8"	870 1914	6.60 21'8"	800 1760
				8.30 27'3"	640 1408

(*) Su gancio fisso - On fixed hook

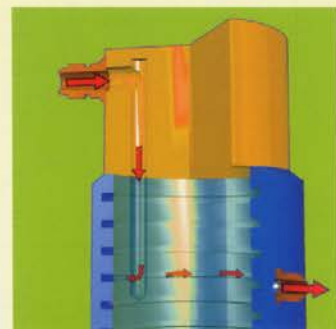

E2	E2	
6800 daN*m	49194 Lb*ft	Momento statico massimo al perno torretta • Max. static moment at the turret pin Moment statique max. a l'axe de la tourelle • Max. statisches ubmoment am kranseulenbolzen
6.61 m	21'8"	Sbraccio idraulico • Hydraulic boom length Longueur du bras hydraulique • Hydraulic reichweite
		Sbraccio con prolunghe manuali • Boom length with manual extensions Longueur du bras avec rallonges manuelles
680 daN*m	4919 Lb*ft	Coppia di rotazione • Slew torque • Moment de rotation • Drehmoment
40 sec 360°	40 sec 360°	Tempo di rotazione • Slewing speed • Temp de rotation • Schwenkgeschwindigkeit
1200+1200mm	3'11"+3'11"	Uscita stabilizzatori (*) • Outriggers extensions (*) Sortie des bequilles (*) • Breite der abstützung (*)
4495 mm	14'9"	Larghezza stabilizzatori (**) • Outriggers width (**) Largeur des bequilles (**) • Breite der abstützung (**)
624 mm	2'1"	Lunghezza • Length • Longeur • Länge
2190 mm	7'2"	Larghezza • Width • Largeur • Breite
1710 mm	5'7"	Altezza • Height • Hauteur • Höhe
985 kg	2172 lbs	Peso (senza olio e montaggio) • Weight (without oil and fitting) Poids (sans huile et montage) • Gewicht (ohne öl und ohne)
14 l/min	4 us gal/min	Portata pompa (***) • Pump delivery (***) • Capacité de la pompe (***) • Pumpenheistung (***)
275 bar	3911 psi	Pressione • Pressure • Pression • Druck
31 l	8 us gal	Capacità serbatoio olio • Oil tank capacity • Capacité de reservoir d'huile • Öl tank inhalt

STANDARD



OPTIONAL

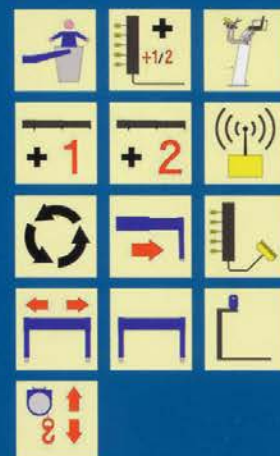

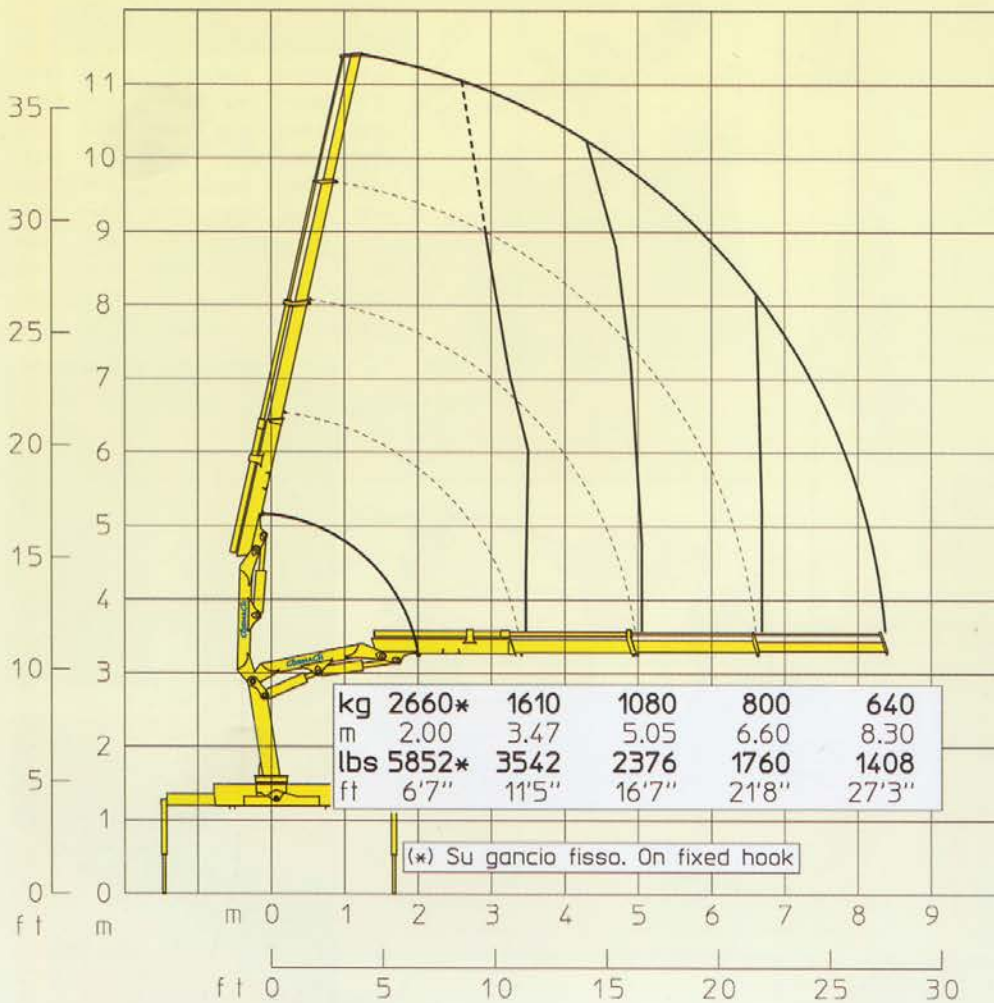

E1		E2		E3	
m/ft	kg/lbs	m/ft	kg/lbs	m/ft	kg/lbs
2.00 6'7"	2820* 6204*	2.00 6'7"	2760* 6079*	2.00 6'7"	2660* 5852*
3.35 10'12"	1750 3850	3.40 11'2"	1690 3718	3.47 11'5"	1610 3542
4.95 16'3"	1200 2640	5.00 16'5"	1160 2550	5.05 16'7"	1080 2376
		6.60 21'8"	870 1914	6.60 21'8"	800 1760
				8.30 27'3"	640 1408

(*) Su gancio fisso - On fixed hook

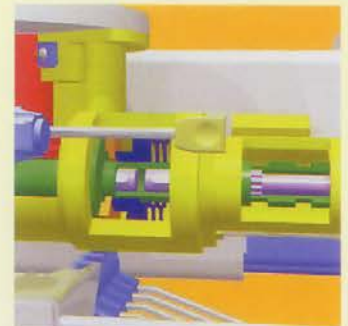

E3	E3	
6800 daN*m	49194 Lb*ft	Momento statico massimo al perno torretta • Max. static moment at the turret pin Moment statique max. a l'axe de la tourelle • Max. statisches ubmoment am Kransaulenbolzen
8.37 m	27'6"	Sbraccio idraulico • Hydraulic boom length Longueur du bras hydraulique • Hydraulic reichweite
		Sbraccio con prolunghe manuali • Bomm length with manual extensions Longueur du bras avec rallonges manuelles
680 daN*m	4919 Lb*ft	Coppia di rotazione • Slew torque • Moment de rotation • Drehmoment
40 sec 360°	40 sec 360°	Tempo di rotazione • Slewing speed • Temp de rotation • Schwenkgeschwindigkeit
1200+1200mm	3'11" + 3'11"	Uscita stabilizzatori (*) • Outriggers extensions (*) Sortie des bequilles (*) • Breite der abstützung (*)
4495 mm	14'9"	Larghezza stabilizzatori (**) • Outriggers width (**) Largeur des bequilles (**) • Breite der abstützung (**)
624 mm	2'1"	Lunghezza • Length • Longeur • Länge
2190 mm	7'2"	Larghezza • Width • Largeur • Breite
1710 mm	5'7"	Altezza • Height • Huteur • Höhe
1060 kg	2337 lbs	Peso (senza olio e montaggio) • Weight (without oil and fitting) Poids (sans huile et montage) • Gewicht (ohne öl und ohne)
14 l/min	4 us gal/min	Portata pompa (***) • Pump delivery (***) • Capacité de la pompe (***) • Pumpenleistung (***)
275 bar	3911 psi	Pressione • Pressure • Pression • Druck
31 l	8 us gal	Capacità serbatoio olio • Oil tank capacity • Capacité de reservoir d'huile • Öl tank inhalt

STANDARD



OPTIONAL

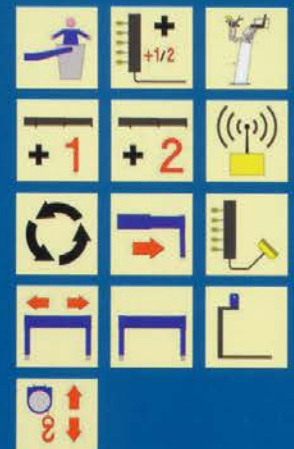

ingombro max.
con multidrom

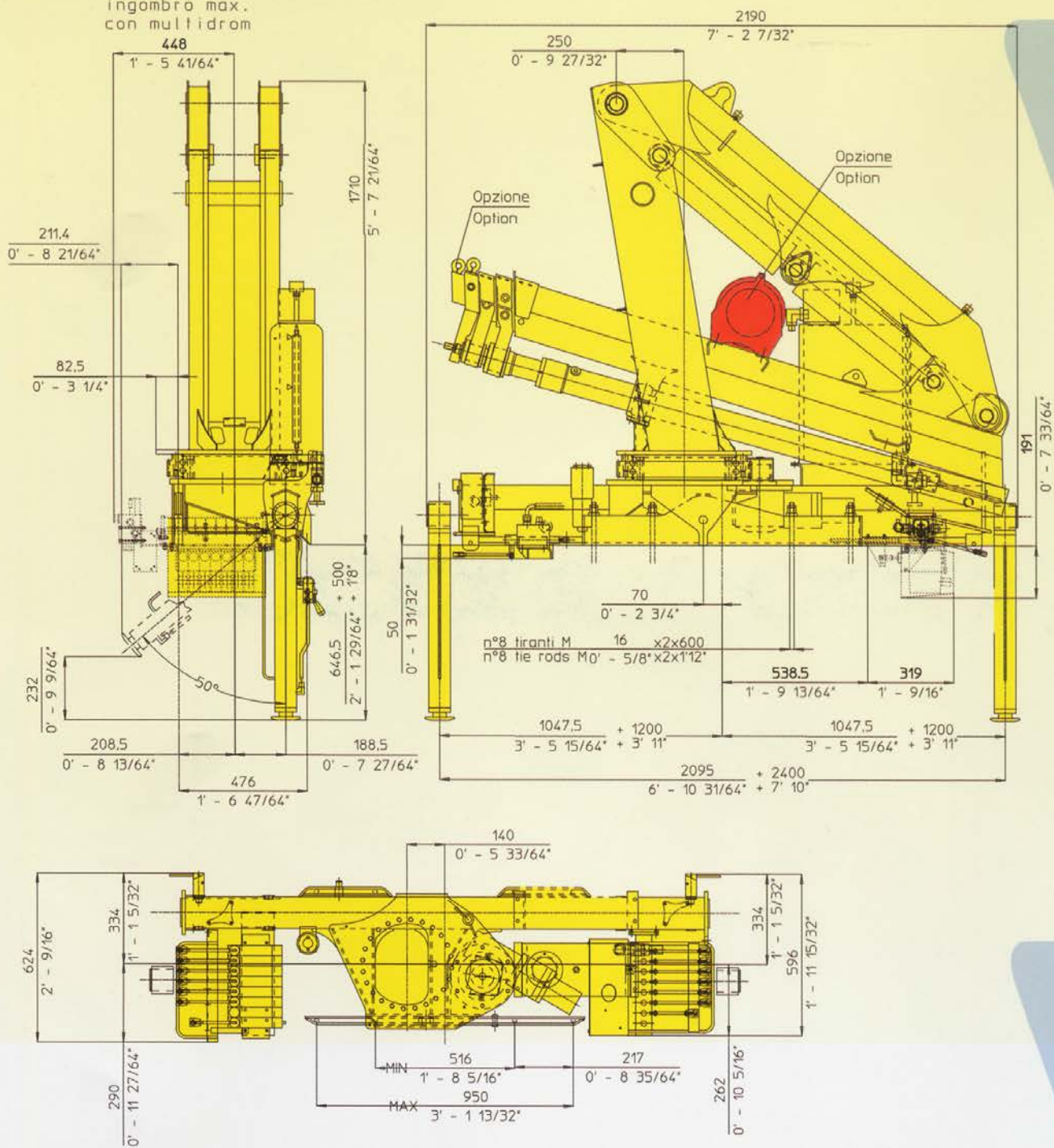

STANDARD



Rotazione 360°
Rotation 360°
Drehbereich 360°



Stabilizzatori gru base girevoli
Tilt up outriggers
Bequilles tournants
Drehbare stützen



Comandi bilaterali
Dual control stations
Commandes à gauche et à droite
Beidseitige Bedienung



Limitatore di momento
Load limiting device
Limiteur de charge
Überlastabschaltung

OPTIONAL



Castello
Basket
Nacelle
Personenkorb



Comando supplementare attivato
Additional function
section du distributeur activée
Zusatzfunktion



Posto di manovra in alto
Top sit
Siège en haut
Hochsitz



Prolonghe meccaniche
Manual extensions
Rallonges manuelles
Manuelle verlängerungen



Prolonghe meccaniche
Manual extensions
Rallonges manuelles
Manuelle verlängerungen



Radiocomando
Radio remote control
Radiocommandes
Funkfernsteuerung



Rotazione continua
Continuous rotation
Rotation continue
Endlos schwenkwerk



Verricello
Winch
Treuil
Seilwinde



Stabilizzatori gru base estendibili idraulicamente
Outriggers with hydraulic extension
Stabilisateurs avec élargissement hydraulique
Hydraulisch Ausfahrbare stützen



Telecomando
Cable remote control
Telecommandes
Kabelfernsteuerung



Traversa ausiliaria estendibile
Additional outriggers with lateral extension
Stabilisateurs supplémentaires avec élargissement
Ausfahrbare Zusatz-stützen



Traversa ausiliaria fissa
Additional outriggers beam
Stabilisateurs supplémentaires
Zusätzliche Abstützbeine



Utilizzo con attrezzo
Additional accessories
Utilisation avec accessoire
Zubehör



CORMAGH

CORMAGH

Cormach s.r.l. - Via Madonnina, 27 - C.P. 199 - 25018 MONTICHIARI (BS) - ITALY
 Tel. 0039.030.9656811 - Telefax 0039.030.9656846.7.8
 E-mail: info@cormach.com - www.cormach.com

A fronte di una continua ricerca tecnologica i dati possono cambiare senza preavviso. Contattare il nostro Ufficio Commerciale per ulteriori informazioni.
 Because of continuous technology research data can change without notice. Please, contact our Commercial Dept. for further information.
 A cause de une continue recherche technologique les données peuvent changer sans préavis. Contacter notre Bureau Commercial pour des autres informations.
 Irrtum und technische Änderung vorbehalten. Unser Vertrieb erteilt Ihnen gerne weitere Auskünfte. Bitte rufen Sie uns an.
 Debido a los continuos avances tecnológicos los datos pueden variar sin notificación previa. Para más información rogamos contactar nuestro Departamento Comercial.