

COMBINATION GRAPPLE

125CHD-A RT-1002STDHT-1

COMBINE

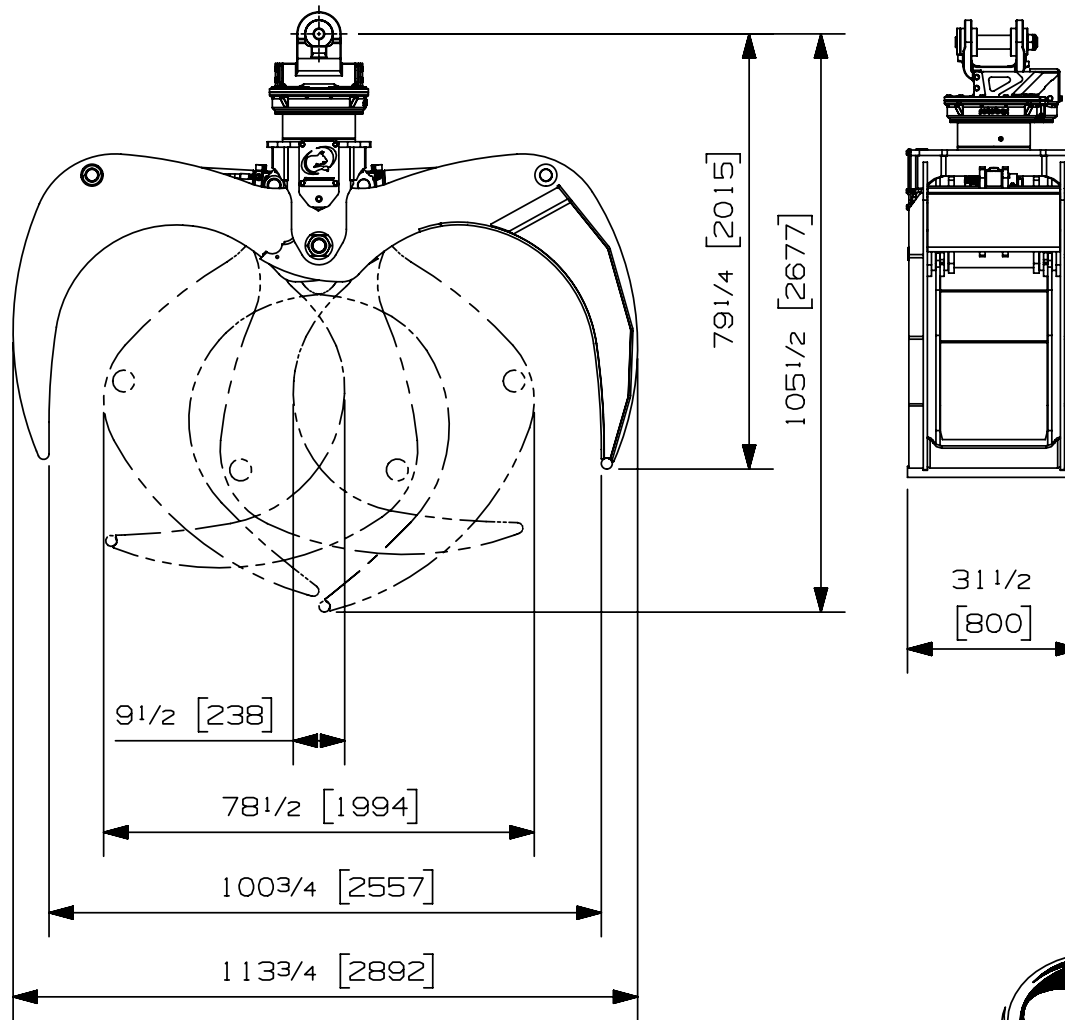

SPECIFICATION TECHNIQUE TECHNICAL DATA

SURFACE UTILE PTE A PTE: 1.25 m² / 13.45 ft²
USEFUL AREA TIP TO TIP:

POIDS: 1724 kg / 3850 lb
WEIGHT:

DIA.DU CYLINDRE: 102 mm / 4 in
CYLINDER DIAMETER:

PRESSION MAXIMUM: 344 bar / 5000 PSI
MAXIMUM PRESSURE:

DEBIT MAXIMUM: 114 l/min / 42 GPM
MAXIMUM FLOW:



ROTOBEC™