



20MS

	P20X	20
Crimping range (mm) <sup>1)</sup>	10-61	10-61
Crimping range (inch) <sup>1)</sup>	0.39-2.40	0.39-2.40
Max. crimping force (kN)	1370	1370
Max. crimping force (tonnage)	137	137
Number of crimpings/hour <sup>2)</sup>	258 / 530 <sup>5)</sup>	250 / 850 <sup>5)</sup>
Hose size ID (inch)	1½	1½
Die set <sup>3)</sup>	P20	P20
Max. opening (mm) <sup>4)</sup>	+25	+25
Master die D/L (mm)	84 / 80	84 / 80
Master die D/L (inch)	3.31 / 3.15	3.31 / 3.15
Control	MS	MS / UC
Motor (kW)	1.5 / 2.2 <sup>5)</sup>	1.5 / 3 <sup>5)</sup>
Motor (HP)	2.0 / 3.0 <sup>5)</sup>	2.0 / 4.0 <sup>5)</sup>
SIZE: length (mm)	525	800
width (mm)	515	630
height (mm)	564	637
SIZE: length (inch)	20.7	31.5
width (inch)	20.3	24.8
height (inch)	22.3	25.1
Weight (kg)	110	157
Weight (lbs)	243	346

Options:
QC-Tool
* Foot pedal
* Electric back stop device
Mechanical back stop device
** UC1, UC2

\* not available in P20X-model  
 \*\* not available in P20X and MS-models



- 1) With standard dies. Crimping range can be increased with special dies.
- 2) Theoretical with 10 mm cycle
- 3) See table for die set data
- 4) Maximum opening is the total die travel. Add this value to the minimum crimping diameter of the die set used. The result is the maximum opening of the machine with die set in place.
- 5) 1-phase / 3-phase

Finn-Power MS and UC controls represent the most advanced crimping controls in the market. An interactive MS can be taught the opening and UC control consists the possibility to be extended with various targets.

Both models save energy with their powersave mode and environment by using eco-friendly rapeseed oil.

An entirely novel construction makes it possible to use the machine both right and left handed and feeding direction can be from front and back. Also normal service actions can be made easily.



20UC



P20X



20UC

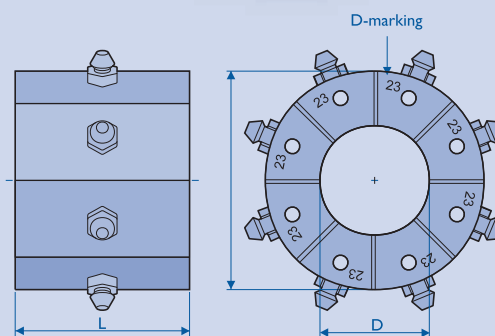

18013 /xx  
P20

Pno	Crimping range	D	L
18013/10	10.0 - 12.0	10	55
18013/12	12.0 - 14.0	12	55
18013/14	14.0 - 16.0	14	55
18013/16	16.0 - 19.0	16	55
18013/19	19.0 - 23.0	19	55
18013/23	23.0 - 27.0	23	55
18013/27	27.0 - 31.0	27	70
18013/31	31.0 - 36.0	31	70
18013/36	36.0 - 41.0	36	75
18013/41	41.0 - 47.0	41	75
18013/47	47.0 - 54.0	47	85
18013/54	54.0 - 61.0	54	85