

ROBOTICS

Single-arm YuMi®

Inherently safe, truly collaborative



Best-in-class safety. Ultimate flexibility. Approachable design. YuMi was engineered to work directly alongside your people, and boost productivity.

Following on from the success of ABB's dual-arm YuMi, introduced in 2015, the world's first truly collaborative robot, ABB has developed a single-arm YuMi to expand its collaborative portfolio.

Versatile installation for convenient deployment

Single-arm YuMi is compact and lightweight (9.5 kg) and supports mounting in any direction including ceiling, table, and wall mounting for rapid and flexible installation to fit into existing production lines. The ultra-light magnesium arm rotates on seven axes to mimic human-like movements with greater agility than 6-axis robots. The robot was specifically designed to meet the flexible production needs required by small parts assembly processes including consumer electronics, consumer goods, and small and medium enterprises.

Easy-to-use lead-through programming

Single-arm YuMi also features the same intuitive, easy-to-use lead-through movement programming as dual-arm YuMi, meaning workers can teach the robot motions and positions easily and quickly, greatly simplifying robot programming. Combining this simplicity with the robot's deployment flexibility, it will help manufacturers in many industries to offset shortages of skilled workers and help reduce entry barriers for new potential robot users, particularly small and medium enterprises.

Extremely versatile, the YuMi family of robots can be combined in numerous configurations. For example, a single-arm YuMi can be used to feed parts to dual-arm YuMi to increase flexibility, or added as an extra arm for more complex assembly tasks requiring more than 2 robot arms.

Wizard easy programming

Single-arm YuMi comes delivered with Wizard, ABB's new graphical programming interface that enables you to quickly create robot programs using drag-and-drop blocks on the Flexpendant.

SaveMove option

To fulfill the enhanced safety requirements of specific usage scenarios, ABB's SafeMove will be available as option for the single-arm YuMi, giving it the full range of safety certified functions that other ABB robots have.

Key features

- 500g rated payload
- Small footprint, 7-axis dexterity
- Very lightweight manipulator, 9.5 kg
- Mounting in any position
- Integrated Gripper with servo gripper, vision and vacuum
- Best-in-class safety design
- High speed and accuracy
- PL d Cat 3 Protective stop and emergency stop

Customer benefits

- Short cycle times
- Fenceless operation
- Lead-through technology
- Wizard easy programming
- Lower investment
- Easier to integrate

Specification

Robot version	Reach (mm)	Payload (g)	Armload
IRB 14050	559	500	No armloads
Integrated signal and power supply		24V Ethernet or 4 Signals	
Integrated air supply		4 Bar	
Integrated ethernet		One 100/10 Base-TX ethernet port	
Robot mounting		All angles AbsAcc available for all mounting positions	
Degree of protection		IP30	
Functional safety		PL d Cat 3 Protective stop and emergency stop SafeMove as option	
Controller		OmniCore	

Picking cycle information

0.5 kg picking cycle	
25* 300 * 25 mm	0.86s

Performance

Position repeatability	0.02 mm
Max TCP Velocity	1.5 m/s
Max TCP Acceleration	11 m/s*s
Acceleration time 0-1m/s	0.12s

Technical information

Physical	
Dimensions bottom	160 mm x 160 mm
Weight	9.5 kg

Movement

Axis movement	Working range	Maximum speed
Axis 1 rotation	-168.5° to 168.5°	180°/s
Axis 2 arm	-143.5° to 43.5°	180°/s
Axis 3 arm	-123.5° to 80.0°	180°/s
Axis 4 wrist	-290.0° to 290.0°	400°/s
Axis 5 bend	-88.0° to 138.0°	400°/s
Axis 6 turn	-229.0° to 229.0°	400°/s
Axis 7 rotation	-168.5° to 168.5°	180°/s

Front view

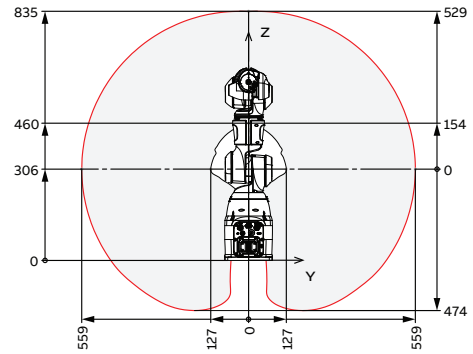

Top view

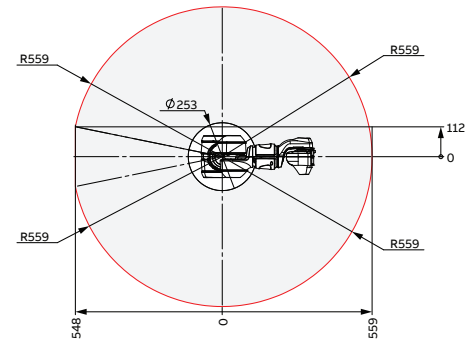

Side view

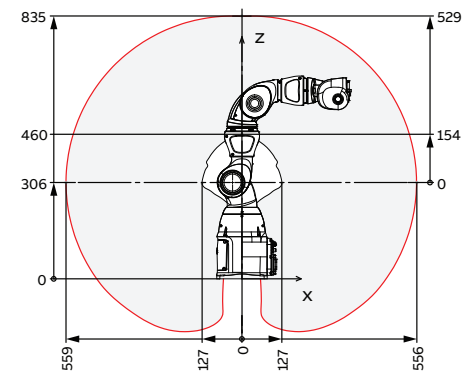

Isometric view

