

## SELF-DRAINING & REMOVABLE BALL 50 mm TRACKBALL IP67 sealed



This unit consists of a 50mm infra-red optical trackball with removable ball and adjustable tracking force, with self-draining and flush through options and with three IP67 rated push button switches.

The whole is mounted on a blackened stainless steel carrier plate and supplied with a silicone sponge sealing the unit onto the customers' panel.

Above features make this trackball unit best suited for extreme dusty environments where cleaning and/or flush through with clear water is required for optimum functionality (f.i. aggressive dust like cement dust, etc..) or for salty water environments (f.i. naval navigation etc...). The adjustable tracking force is another advantage for "unstable" working conditions like for instance in the naval navigation.

### Main features

- Removable ball
- Adjustable tracking force
- Self-draining & flush through
- Waterproof infra-red optical sensing
- Incl. panel seal

### Typical applications

- Naval (salt water)
- Aggressive dusty environments
- Unstable operation conditions (transport, etc..)

### GENERAL TECHNICAL SPECIFICATIONS

Sealing : IP68 waterproof  
 Carrier plate : black epoxy coated stainless steel  
 Ball diameter : 50,8 mm  
 Ball material : epoxy resin  
 Dimensions: 100 x 116 x 40 mm  
 Weight : 0,6 kg  
 Tracking force : adjustable, from free running to high force  
 Lifetime : >= 2 million ball revolutions  
 Cable : shielded, straight 1,6 m long  
 Operating temperature range : 0°C to +60°C  
 Storage temperature range : -25°C to +80°C

### Push button switches

Sealing : IP67  
 Travel : 1,5 mm  
 Operating force : 3N typ  
 Body : PBT & polyamide  
 Contacts : gold plated silver  
 Mechanical life : 1 million oper.

CE : compliant to EMC Directive 89/336/EEC for Electromagnetic Compatibility. Low Voltage Directive 73/23/EEC not applicable for our trackballs.

### CONNECTIVITY

This combo PS/2 & USB trackball unit has a 1,6 meter long shielded straight cable ended by a USB type A plug. An adaptor to PS/2 is added. No special device driver is needed, use standard available drivers of your operating system.

\* Due to the increasing differences of the PS/2 mouse port specifications of the various PC manufacturers, we do recommend that this unit should be tested on the final PC configuration and operating system prior to installing it in series.

### ORDER INFO

TSW50F5 Self-draining & removable ball

Output : PS/2 & USB Combo

### Self-draining option

The trackball is supplied with its draining hole sealed by a rubber insert. If required, this insert can easily be removed by the user and replaced by an adequate tube in order to drain any liquids from the trackball to the outside of the users' cabinet.

SELF-DRAINING & REMOVABLE BALL 50 mm TRACKBALL  
IP67 sealed

DIMENSIONAL DRAWING

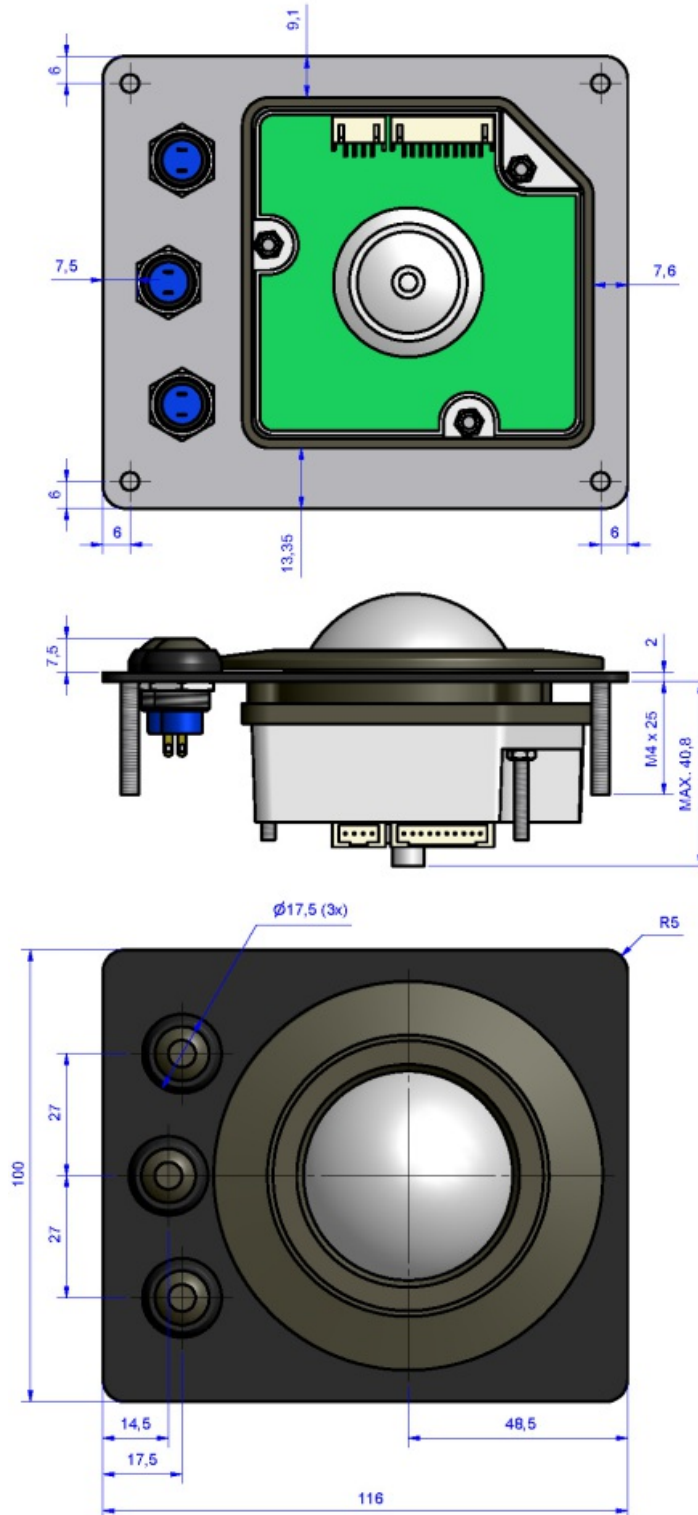

Dim. in mm