

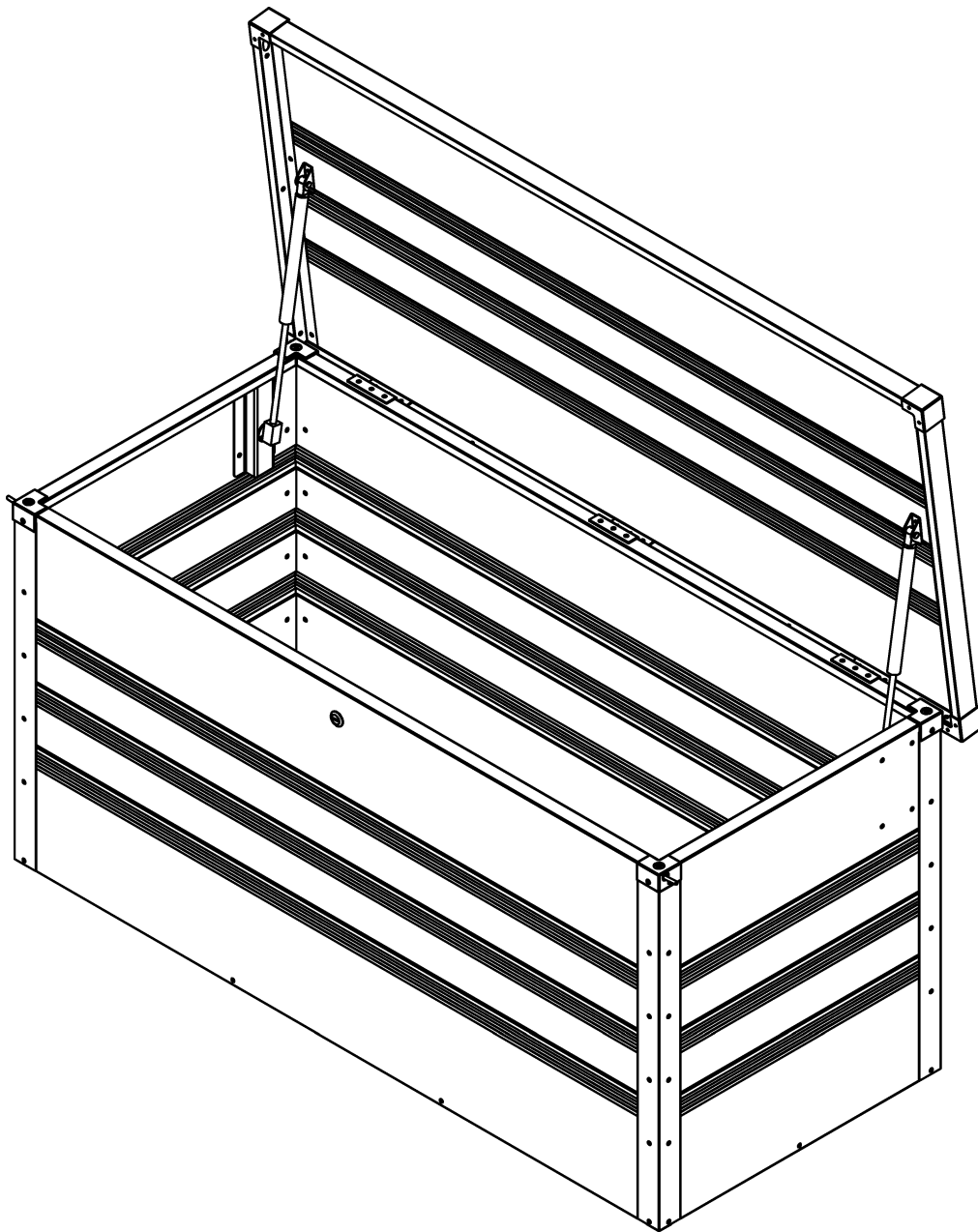

Réf 2988

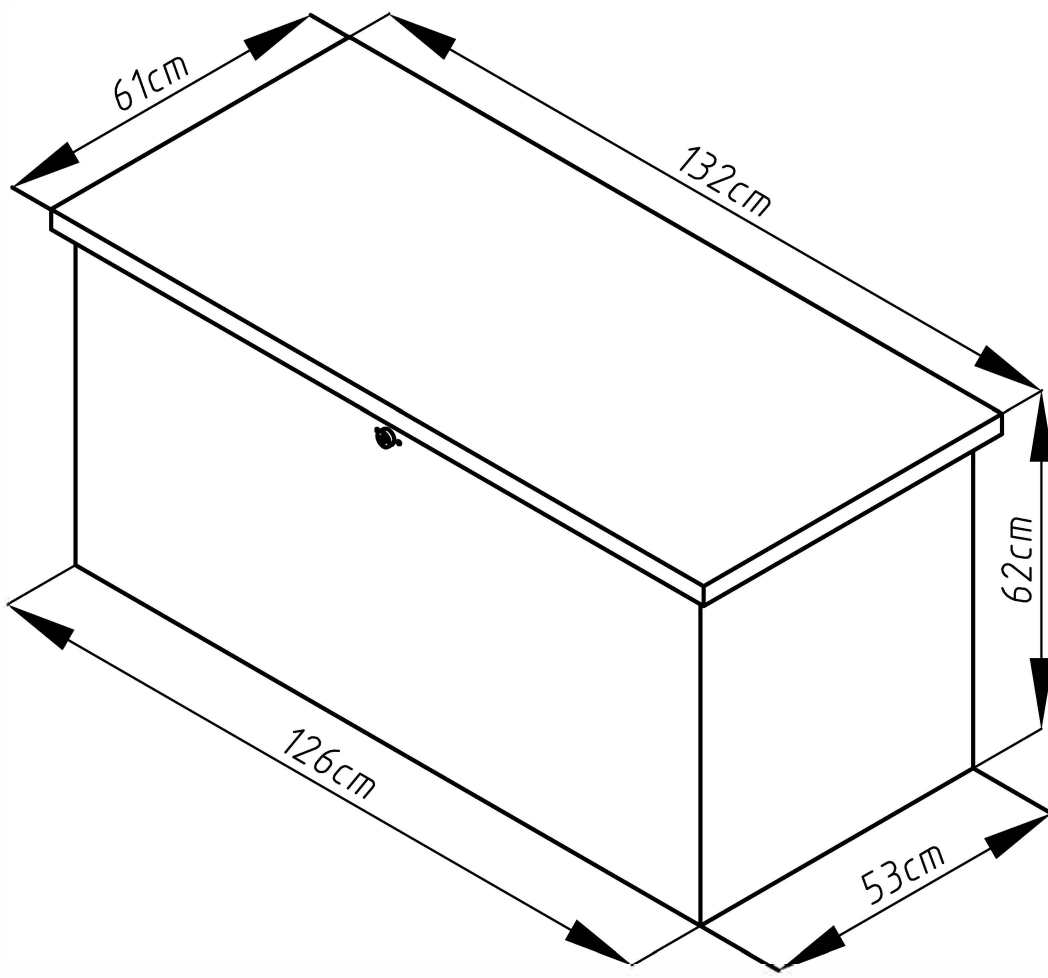

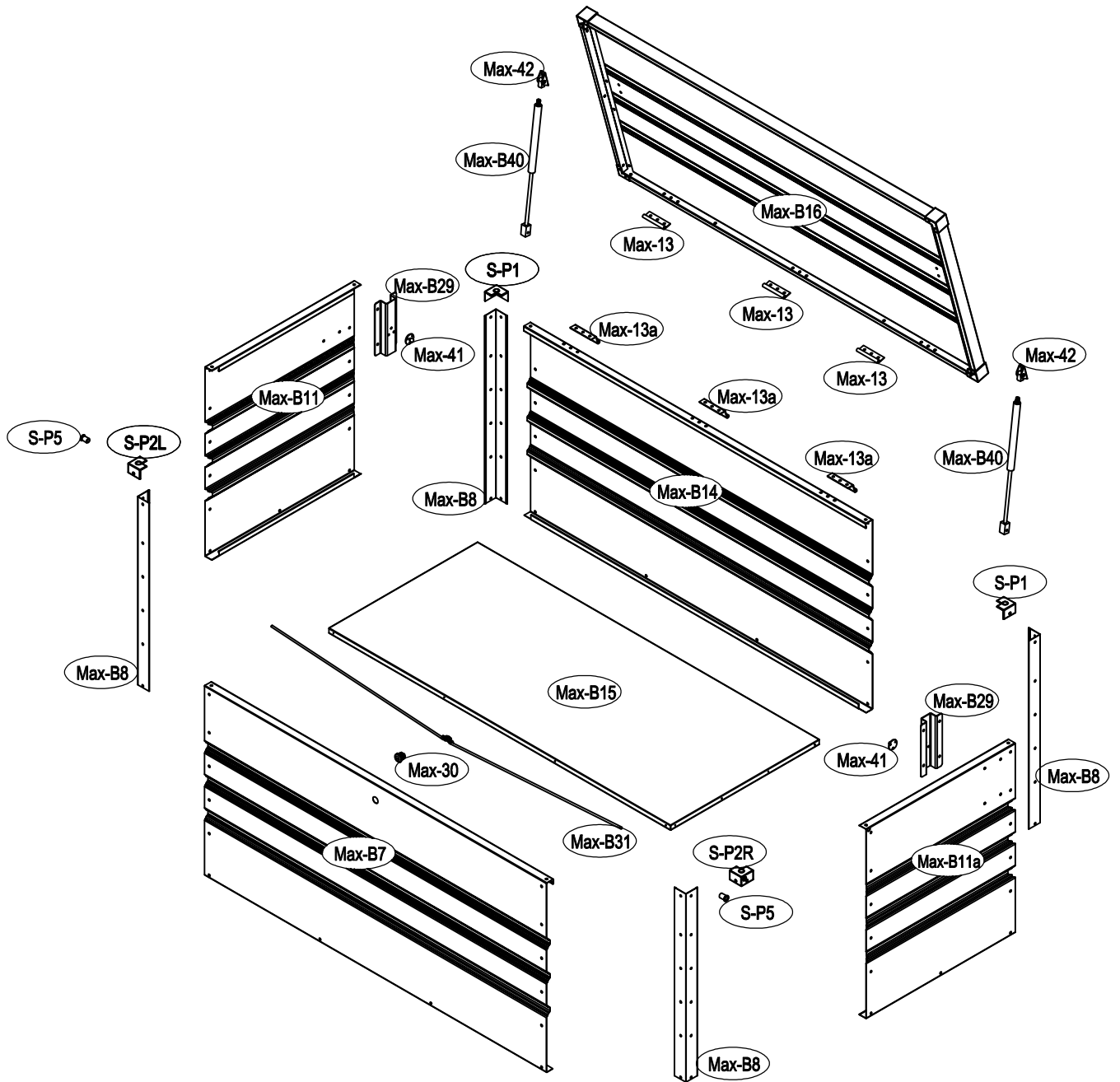





1

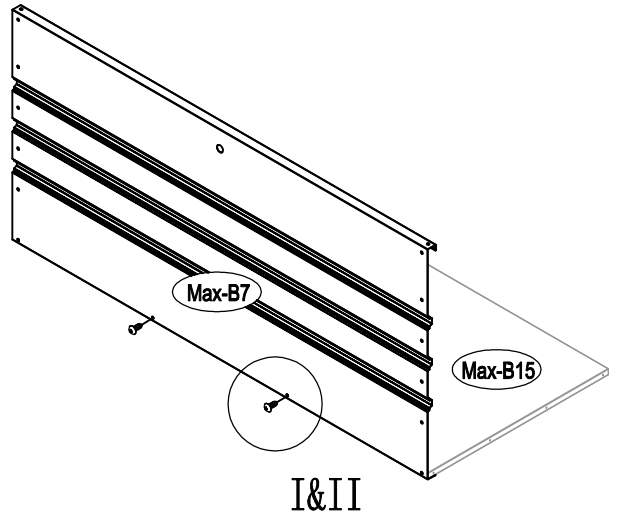
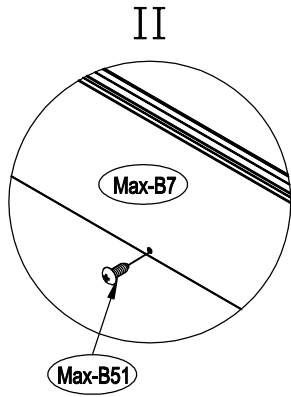
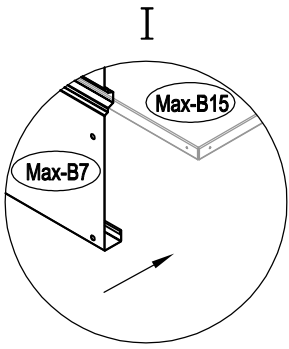

Max-B51 x2

2

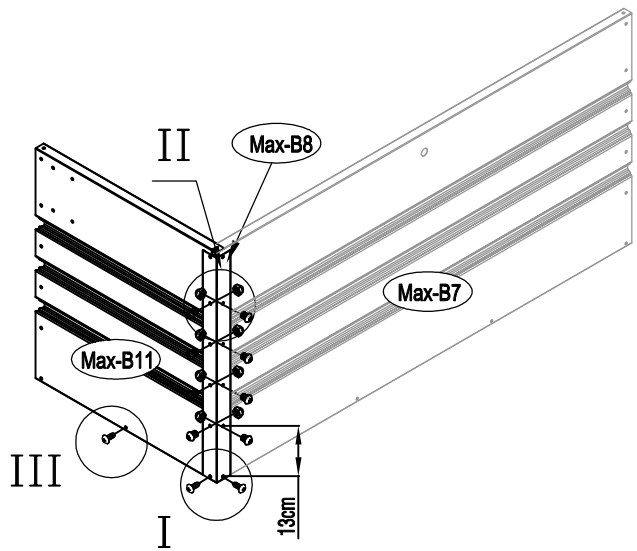
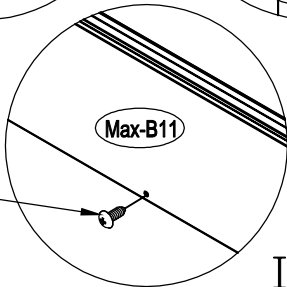
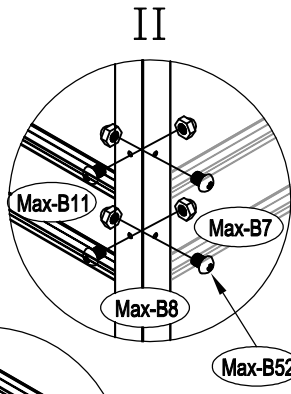
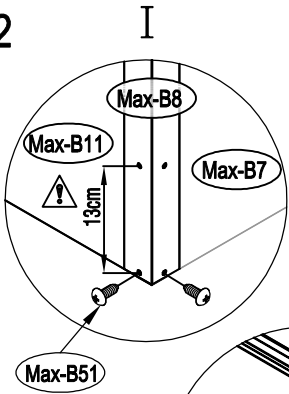

Max-B51 x3 Max-B52 x8

3

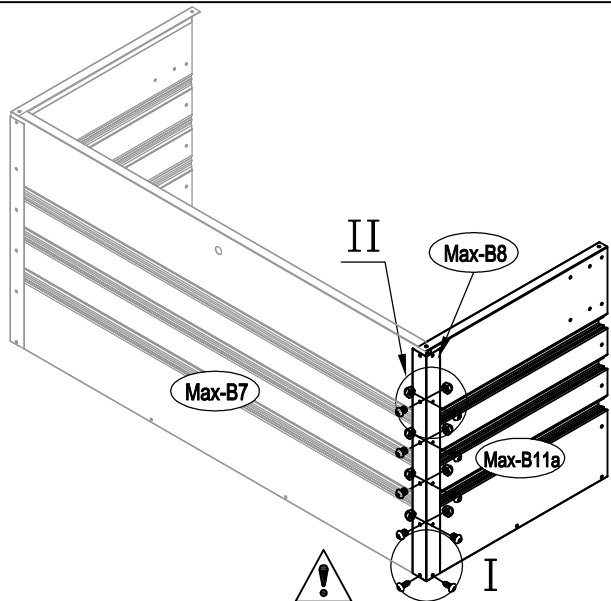
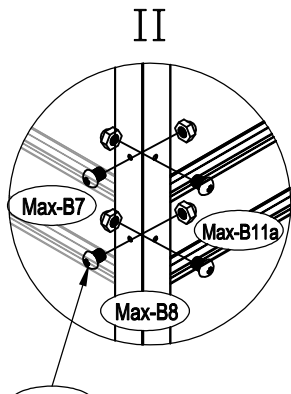
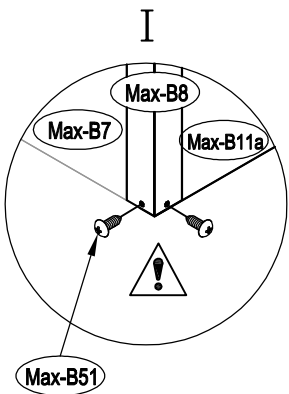

Max-B51 x2 Max-B52 x8

1



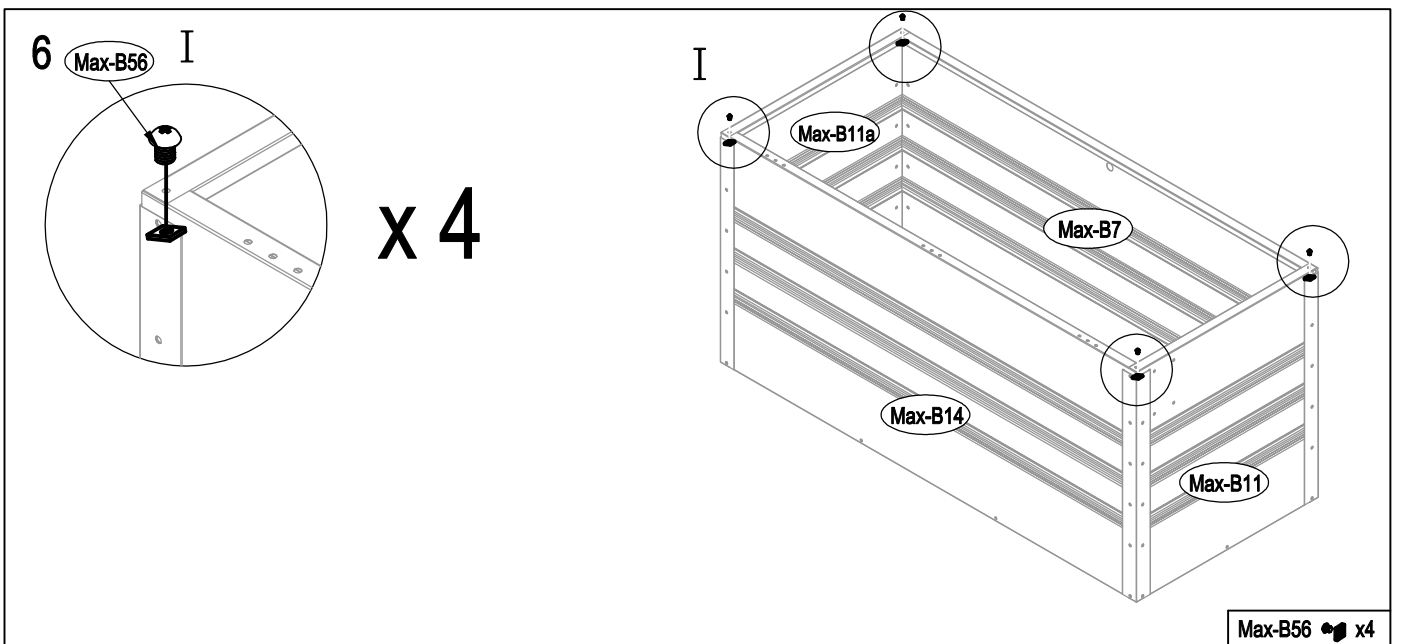
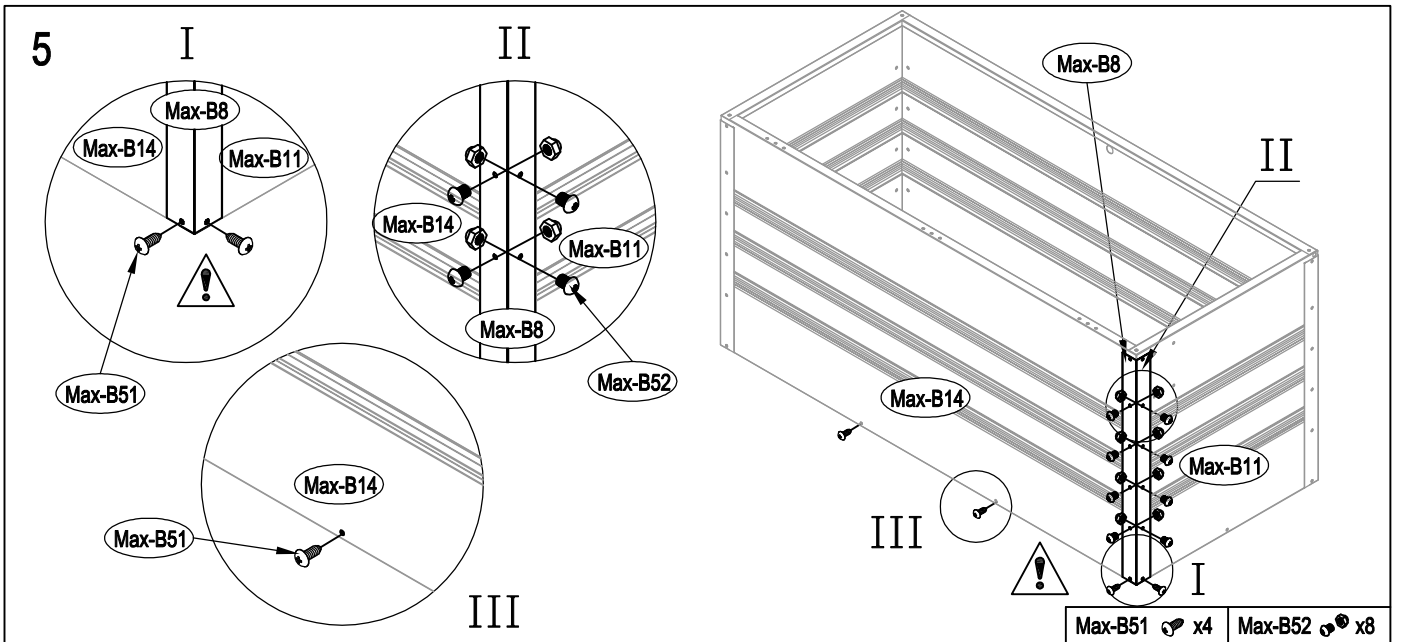
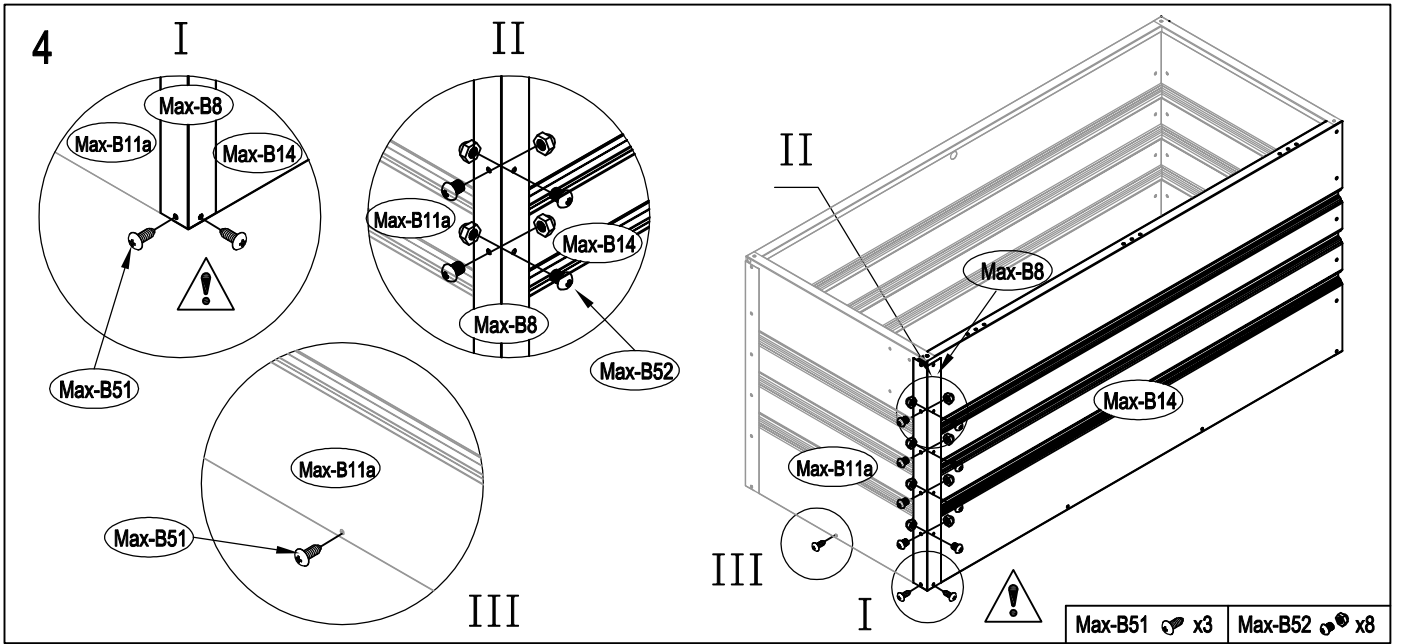

7

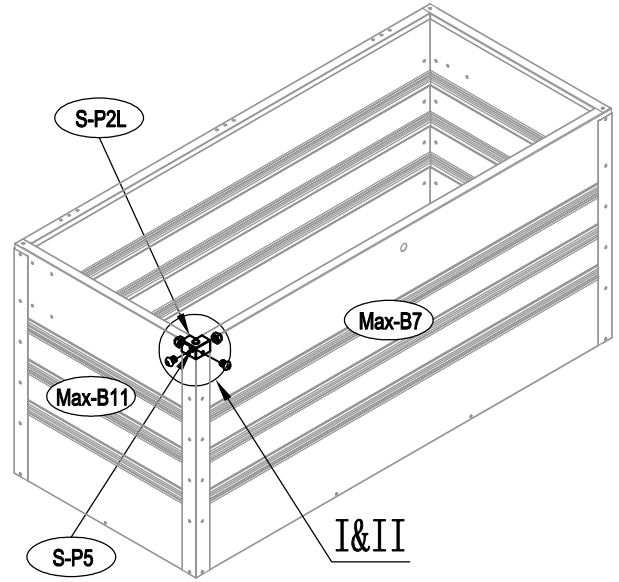
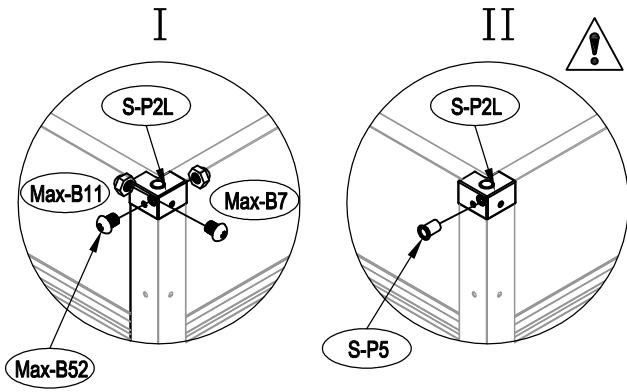

S-P2L		x1	S-P5		x1	Max-B52		x2
-------	--	----	------	--	----	---------	--	----

8

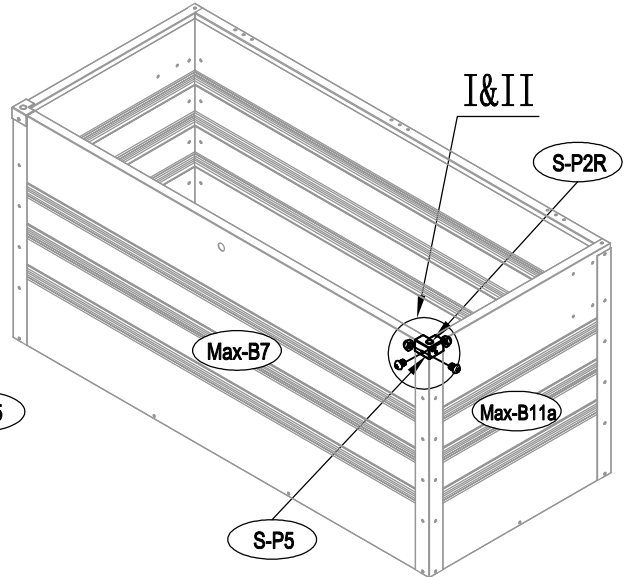
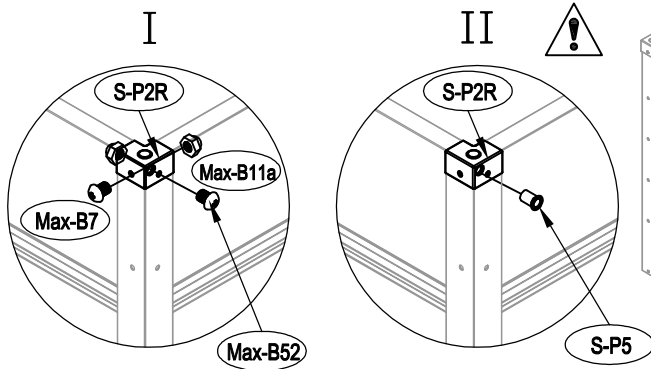

S-P2R		x1	S-P5		x1	Max-B52		x2
-------	--	----	------	--	----	---------	--	----

9

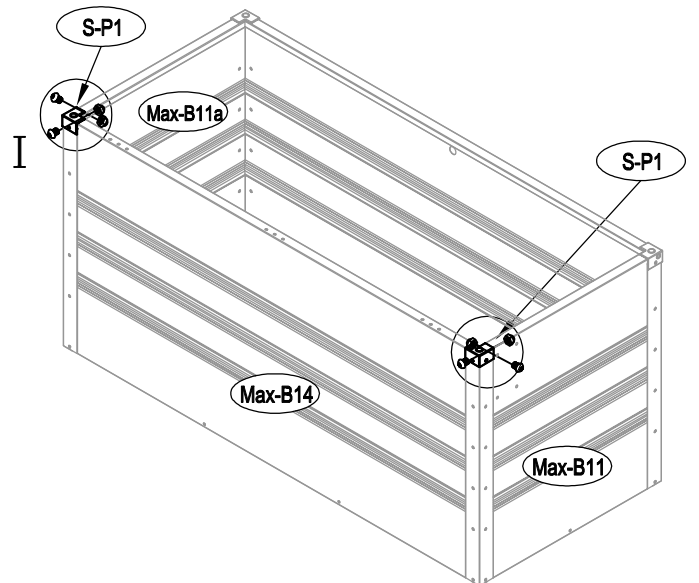
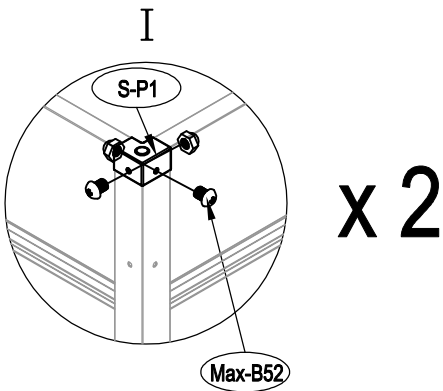



S-P1		x2	Max-B52		x4
------	--	----	---------	--	----



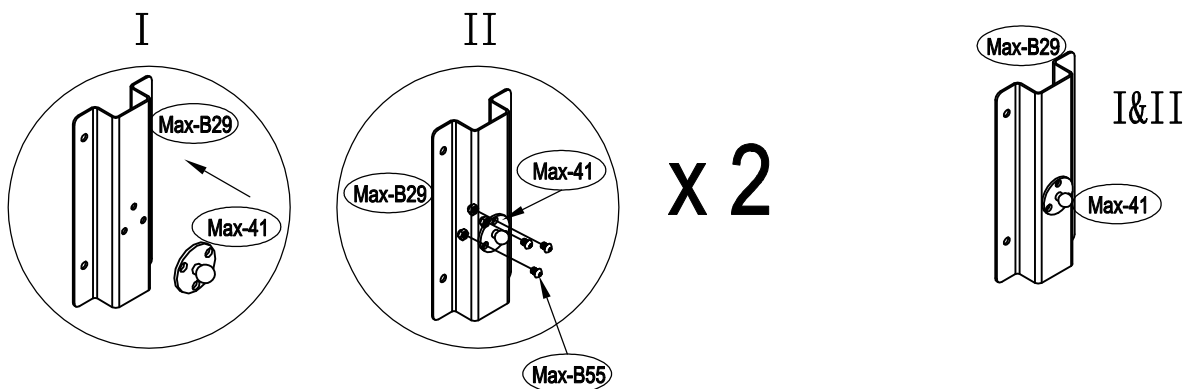

10

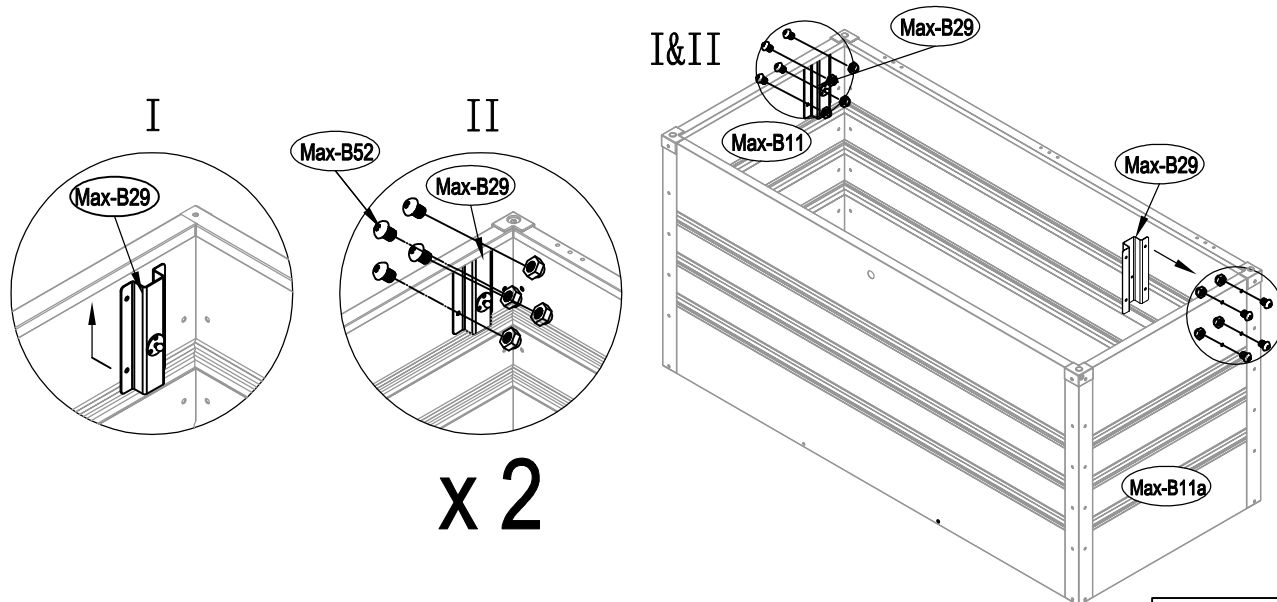

Max-41  x2 Max-B55  x6

11



Max-B52  x8

12

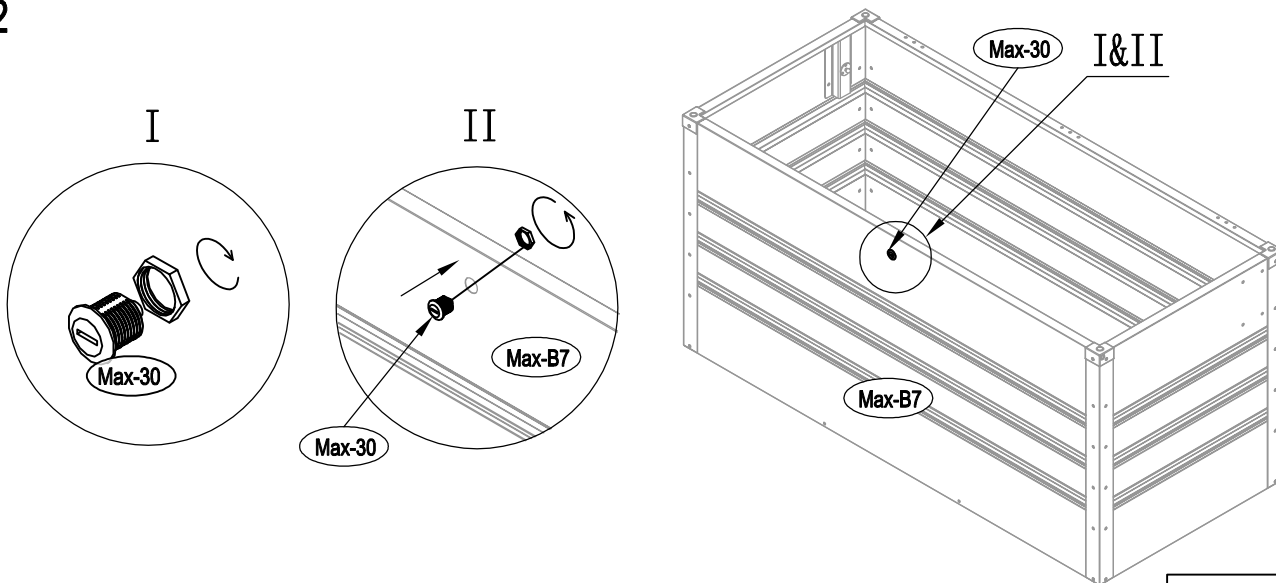

Max-30  x1





13

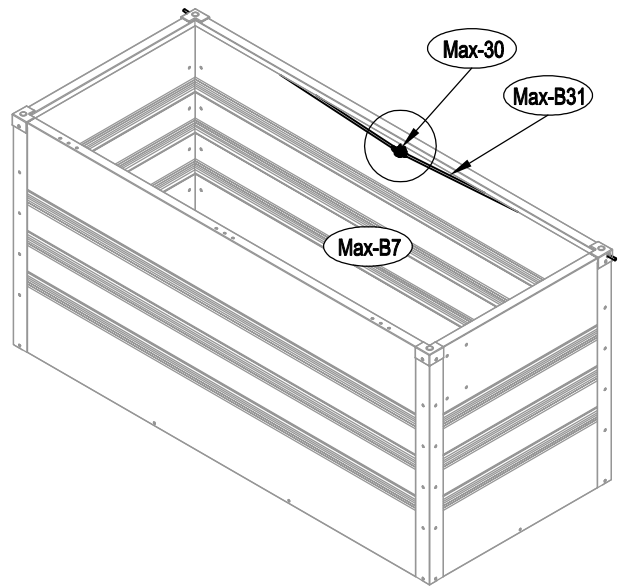
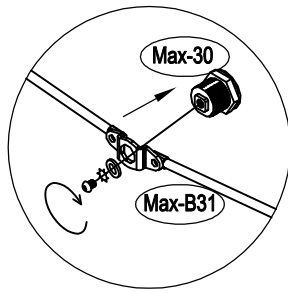
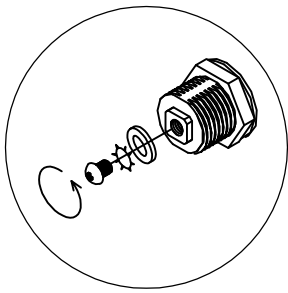

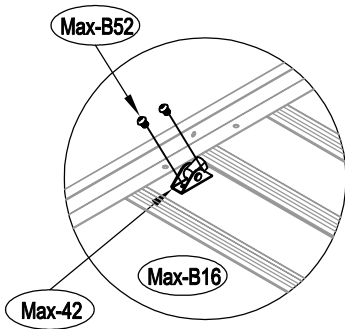

14

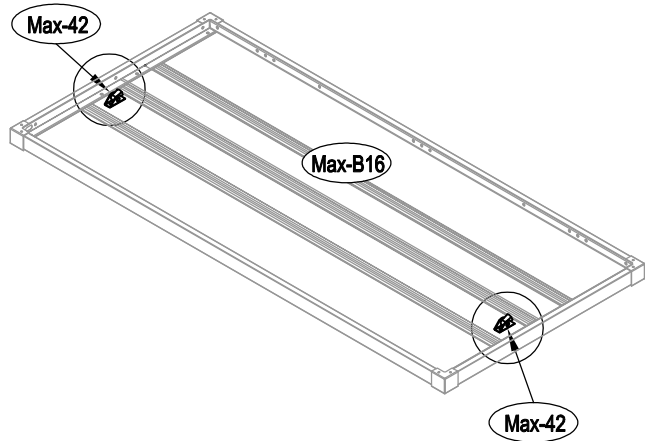

x 2





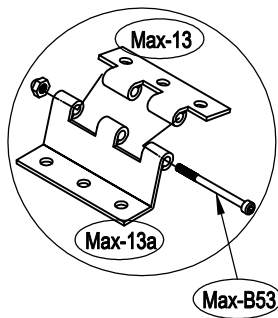

Max-42  x2 Max-B52  x4

15

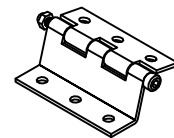

x 3



Max-13  x3 Max-13a  x3 Max-B53  x3



16

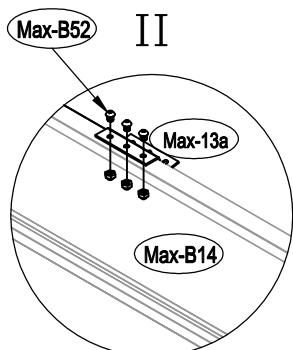
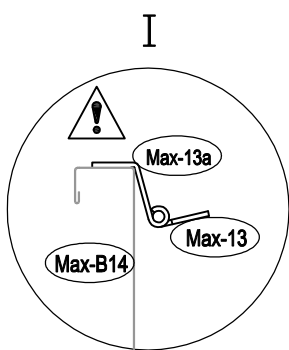

x 3

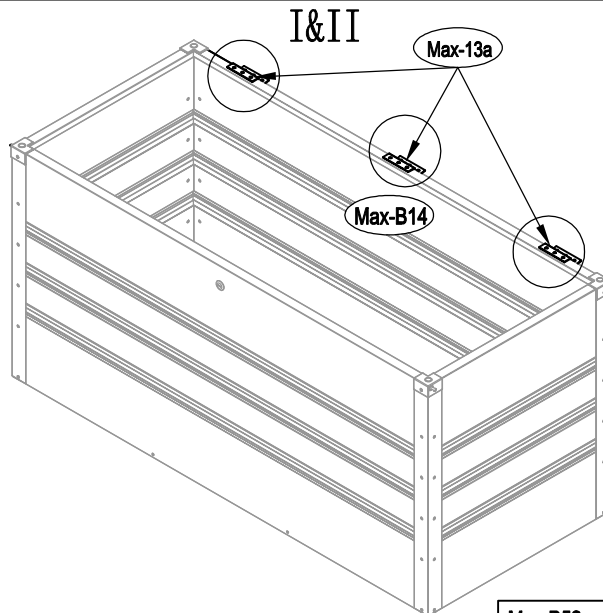

Max-B52 x9

17

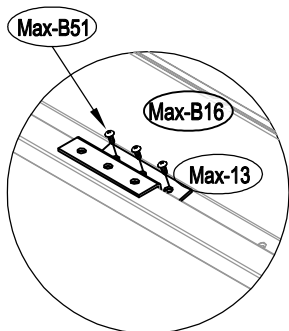

x 3

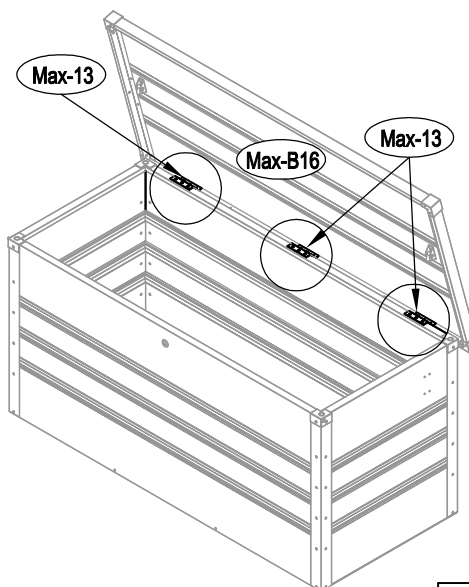

Max-B51 x9

18

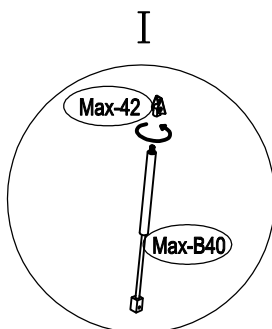

x 2

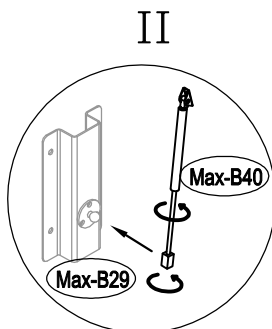

x 2

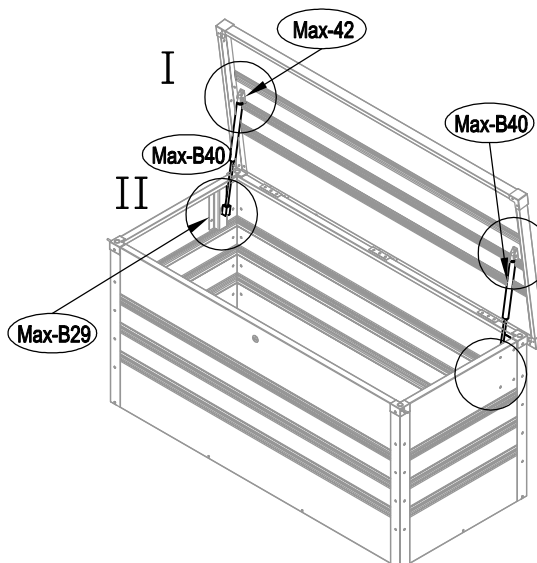

Max-B40 x2

