

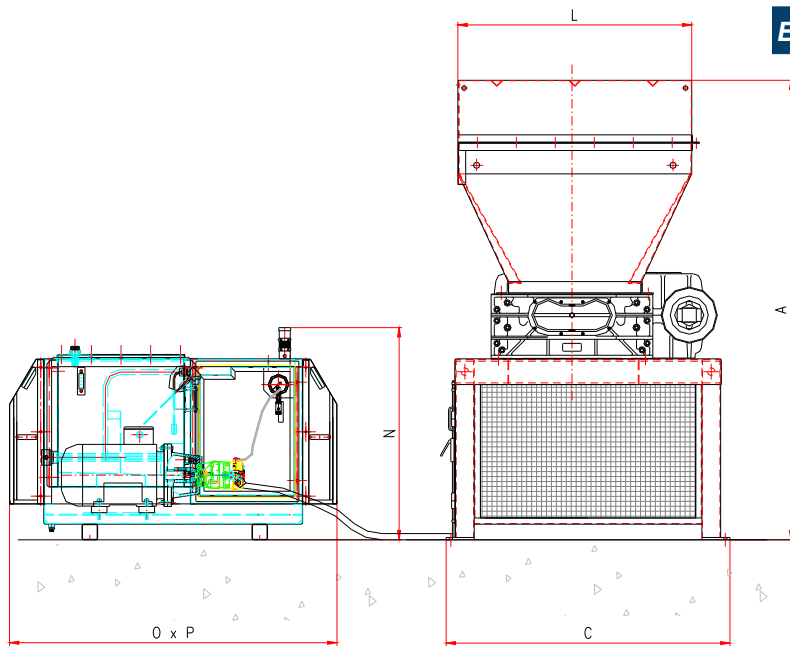





K 8/50
K10/50
K13/50

Dati tecnici Technical data	K 8/50	K 10/50	K 13/50
Camera di lavoro (mm) Shredding chamber (mm)	758x850	1008x850	1258x850
Lame da 30 mm (n.) 30 mm blades (no.)	25	33	41
Lame da 50 mm (n.) 50 mm blades (no.)	15	20	25
Potenza (kW) Power (kW)	37	37	37
Tensione (V) Voltage (V)	220/400/460	220/400/460	220/400/460
Peso (kg) Weight (kg)	3600+1100	4000+1100	4400+1100

Dati Tecnici/Technical Data



Esempi di materiali trattati / Some applications:

- 
Fusti di ferro
Metal drums
60 ÷ 100 pcs/h
- 
Pneumatici da auto
Car tyres
2,5 ÷ 3 t/h
- 
Plastica
Plastics
800 ÷ 2000 Kg/h
- 
Rifiuti industriali
Industrial scraps
1000 ÷ 3000 Kg/h
- 
Rifiuti solidi urbani
Urban waste
1000 ÷ 3000 Kg/h

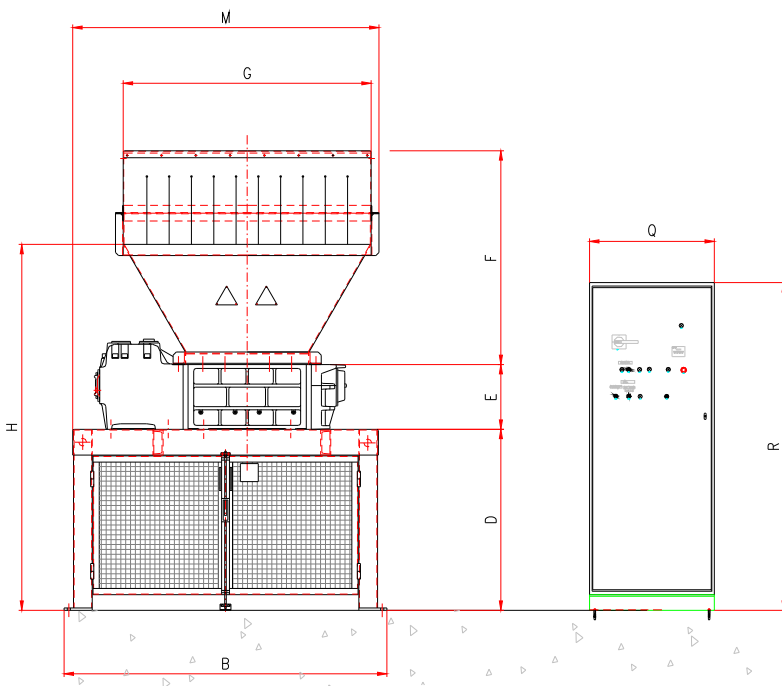

	K8/50	K10/50	K13/50
A	2945	2945	2945
B	2070	2170	2420
C	1820	1820	1820
D	1160	1160	1160
E	415	415	415
F	1370	1370	1370
G	1590	1840	2090
H	2345	2345	2345
L	1500	1500	1500
M	1964	2189	2439
N	1360	1360	1360
O	2100	2100	2100
P	1120	1120	1120
Q	800	800	800
R	2100	2100	2100

CAT1010 Rev. A 04/15

SatrindTech S.r.l.

Via Monfalcone, 122 - 20010 Arluno (MI) - Italy

Tel. (+39) 02 90376683

Fax (+39) 02 90376721

info@satrindtech.com

www.satrindtech.com

